



DEPARTMENT OF EDUCATION

**GRADE 8**

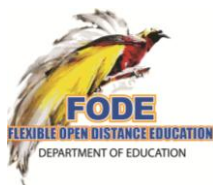
**MATHEMATICS**

**STRAND 2**



**SPACE AND SHAPES**

Published by:



**FLEXIBLE OPEN AND DISTANCE EDUCATION  
PRIVATE MAIL BAG, P.O. WAIGANI, NCD  
FOR DEPARTMENT OF EDUCATION  
PAPUA NEW GUINEA**

**GRADE 8****MATHEMATICS****STRAND 2****SPACE AND SHAPES**

<b>SUB-STRAND 1:</b>	<b>ANGLES AND SHAPES</b>
<b>SUB-STRAND 2:</b>	<b>CIRCLES</b>
<b>SUB-STRAND 3:</b>	<b>SIMILARITY AND SCALE DRAWING</b>
<b>SUB-STRAND 4:</b>	<b>TESSELLATION</b>

### **Acknowledgements**

We acknowledge the contributions of all Secondary and Upper Primary Teachers who in one way or another helped to develop this Course.

Special thanks is given to the Staff of the Mathematics Department of FODE who played active role in coordinating writing workshops, outsourcing lesson writing and editing processes, involving selected teachers of NCD.

We also acknowledge the professional guidance provided by the Curriculum Development and Assessment Division throughout the processes of writing and, the services given by the members of the Mathematics Review and Academic Committees.

The development of this book was co-funded by GoPNG and World Bank.

**MR. DEMAS TONGOGO**  
Principal- FODE

Written by: Luzviminda B. Fernandez



Flexible Open and Distance Education  
Papua New Guinea

Published in 2016

@ Copyright 2016, Department of Education  
Papua New Guinea

All rights reserved. No part of this publication may be reproduced, stored in a retrieval system, or transmitted in any form or by any means electronic, mechanical, photocopying, recording or any other form of reproduction by any process is allowed without the prior permission of the publisher.

**ISBN: 978 - 9980 - 87 - 256 - 2**

National Library Services of Papua New Guinea

Printed by the Flexible, Open and Distance Education

## CONTENTS

	<b>Page</b>
Secretary's Message.....	4
Strand Introduction.....	5
Study Guide.....	6
<b>SUB-STRAND 1:      ANANGLES AND SHAPES</b> .....	<b>7</b>
<input type="checkbox"/> Lesson 1:      Adjacent Angles.....	9
<input type="checkbox"/> Lesson 2:      Angles at a Point and Vertical Angles .....	16
<input type="checkbox"/> Lesson 3:      Angles Formed by a Transversal.....	22
<input type="checkbox"/> Lesson 4:      Angle Sum of a Triangle.....	28
<input type="checkbox"/> Lesson 5:      Angle Sum of a Quadrilateral.....	33
<input type="checkbox"/> Lesson 6:      Isosceles and Equilateral Triangles.....	39
Summary.....	43
Answers to Practice Exercises 1 – 6 .....	44
<b>SUB-STRAND 2:      CIRCLES</b> .....	<b>47</b>
<input type="checkbox"/> Lesson 7:      What is a Circle? .....	49
<input type="checkbox"/> Lesson 8:      Parts of a Circle.....	53
<input type="checkbox"/> Lesson 9:      Naming Parts of a Circle.....	59
<input type="checkbox"/> Lesson 10:      Circumference of a Circle.....	65
<input type="checkbox"/> Lesson 11:      The Number Pii ( $\pi$ ).....	71
<input type="checkbox"/> Lesson 12:      Solving Problems Involving Circumference.....	77
Summary.....	84
Answers to Practice Exercises 7 – 12 .....	85
<b>SUB-STRAND 3:      SIMILARITY AND SCALE DRAWING</b> .....	<b>89</b>
<input type="checkbox"/> Lesson 13:      Similarity.....	91
<input type="checkbox"/> Lesson 14:      Corresponding Angles and Sides (Part 1).....	94
<input type="checkbox"/> Lesson 15:      Corresponding Angles and Sides (Part 2).....	106
<input type="checkbox"/> Lesson 16:      Drawing Similar Triangles.....	113
<input type="checkbox"/> Lesson 17:      Drawing More Similar Shapes.....	119
<input type="checkbox"/> Lesson 18:      Scale Drawing .....	124
Summary.....	134
Answers to Practice Exercises 13 – 18 .....	135
<b>SUB-STRAND 4:      TESSELLATIONS</b> .....	<b>141</b>
<input type="checkbox"/> Lesson 19:      Plane Shapes and Patterns.....	143
<input type="checkbox"/> Lesson 20:      Translation.....	151
<input type="checkbox"/> Lesson 21:      Rotation.....	156
<input type="checkbox"/> Lesson 22:      Symmetry.....	162
<input type="checkbox"/> Lesson 23:      Line Symmetry .....	168
<input type="checkbox"/> Lesson 24:      Rotational Symmetry.....	172
Summary.....	178
Answers to Practice Exercises 20 – 24 .....	179
<b>REFERENCES</b> .....	<b>185</b>

## SECRETARY'S MESSAGE

---

Achieving a better future by individual students and their families, communities or the nation as a whole, depends on the kind of curriculum and the way it is delivered.

This course is part and parcel of the new reformed curriculum. The learning outcomes are student-centered with demonstrations and activities that can be assessed.

It maintains the rationale, goals, aims and principles of the national curriculum and identifies the knowledge, skills, attitudes and values that students should achieve.

This is a provision by Flexible, Open and Distance Education as an alternative pathway of formal education.

The course promotes Papua New Guinea values and beliefs which are found in our Constitution and Government Policies. It is developed in line with the National Education Plans and addresses an increase in the number of school leavers as a result of lack of access to secondary and higher educational institutions.


Flexible, Open and Distance Education curriculum is guided by the Department of Education's Mission which is fivefold:

- to facilitate and promote the integral development of every individual
- to develop and encourage an education system that satisfies the requirements of Papua New Guinea and its people
- to establish, preserve and improve standards of education throughout Papua New Guinea
- to make the benefits of such education available as widely as possible to all of the people
- to make the education accessible to the poor and physically, mentally and socially handicapped as well as to those who are educationally disadvantaged.

The college is enhanced through this course to provide alternative and comparable pathways for students and adults to complete their education through a one system, two pathways and same outcomes.

It is our vision that Papua New Guineans harness all appropriate and affordable technologies to pursue this program.

I commend all the teachers, curriculum writers and instructional designers who have contributed towards the development of this course.



.....  
**DR. UTE KOMBRA, PhD**  
Acting Secretary for Education

**STRAND 2: SPACES AND SHAPES**

---



Dear student,

This is Strand 2 of the Grade 8 Mathematics Course. It is based on the NDOE Upper Primary Mathematics Syllabus and curriculum Framework for Grade 8 as part of the continuum of Mathematics knowledge and learning from Grade 6 to 8.

**This Strand consists of four Sub-strands:**

- |                      |                                     |
|----------------------|-------------------------------------|
| <b>Sub-strand 1:</b> | <b>Angles and Shapes</b>            |
| <b>Sub-strand 2:</b> | <b>Circles</b>                      |
| <b>Sub-strand 3:</b> | <b>Similarity and Scale Drawing</b> |
| <b>Sub-strand 4:</b> | <b>Tessellation</b>                 |

Sub-strand 1- **Angles and Shapes** – In this topic you will learn to use words to identify and describe angles and shapes accurately and to investigate the properties of interior and exterior angles of polygons.

Sub-strand 2- **Circles** – In this topic you will learn to make physical models of circles and investigate their properties.

Sub-strand 3- **Similarity and Scale Drawing** – In this topic you will learn to identify congruent and similar shapes stating the relevant conditions.

Sub-strand 4- **Tessellation** – In this topic you will learn to investigate rotational symmetry and create tessellations that have rotational symmetry.

You will find that each lesson has reading materials to study, worked examples and a Practice Exercise for you to complete. The answers to the practice exercises are given at the end of each sub-strand.

All the lessons are written in simple language with comic characters to guide you. The practice exercises are graded to help you to learn the process of working out problems.

We hope you enjoy studying this Stand.

All the best!

Mathematics Department  
FODE

## STUDY GUIDE

---

**Follow the steps given below as you work through the Strand.**

- Step 1: Start with SUB-STRAND 1 Lesson 1 and work through it.
- Step 2: When you complete Lesson 1, do Practice Exercise 1.
- Step 3: After you have completed Practice Exercise 1, check your work. The answers are given at the end of the SUB-STRAND 1.
- Step 4: Then, revise Lesson 1 and correct your mistakes, if any.
- Step 5: When you have completed all these steps, tick the check-box for the Lesson, on the Contents Page (page 3) like this:

Lesson 1: Adjacent Angles

Then go on to the next Lesson. Repeat the process until you complete all of the lessons in Sub-strand 1.

As you complete each lesson, tick the check-box for that lesson, on the Content Page (3), like this . This helps you to check on your progress.

- Step 6: Revise the Sub-strand using Sub-strand 1 Summary, then do Sub-strand Test 1 in Assignment 2.

Then go on to the next Sub-strand. Repeat the process until you complete all of the four Sub-strands in Strand 2.

**Assignment:** (Four Sub-strand Tests and a Strand Test)

When you have revised each Sub-strand using the Sub-strand Summary, do the Sub-strand Test for that Sub-strand in your Assignment. The Course book tells you when to do each Sub-strand Test.

When you have completed the four Sub-strand Tests, revise well and do the Strand Test. The Assignment tells you when to do the Strand Test.

The Sub-strand Tests and the Strand Test in the Assignment will be marked by your Distance Teacher. The marks you score in each Workbook will count towards your final mark. If you score less than 50%, you will repeat that Assignment.

Remember, if you fail by scoring less than 50% in three Assignments, your enrolment will be cancelled. So, work carefully and make sure that you pass all of the Assignments.

## **SUB-STRAND 1**

### **ANGLES AND SHAPES**

**Lesson 1: Adjacent Angles**

**Lesson 2: Angles at a Point and Vertical Angles**

**Lesson 3: Angles Formed by a Transversal**

**Lesson 4: Angle Sum of a Triangle**

**Lesson 5: Angle Sum of a Quadrilateral**

**Lesson 6: Isosceles and Equilateral Triangles**



**SUB-STRAND 1: ANGLES AND SHAPES**

---

**Introduction**

This is the first Sub-strand of Strand 2 for Grade 8 Mathematics. In this Sub-strand, you will extend your learning of useful and interesting facts about Geometry.

In Grade 7, many basic geometrical facts were learnt about angles and shapes. These facts and other knowledge will be used to develop logical reasoning. It is important therefore that you revise them.

Angles and shapes are all around us.

Below is an example of an object where you can see angles and shapes.



In this Sub-strand, you will use appropriate words to identify and describe angles and shapes. You will also investigate the properties of the interior and exterior angles of polygons.

## Lesson 1: Adjacent Angles



You learnt about angles and the properties of angles in Grade 7.



In this lesson, you will:

- identify and describe adjacent angles
- identify and describe complementary and supplementary angles
- solve for the size or measure of an unknown angle given its complement or supplement.

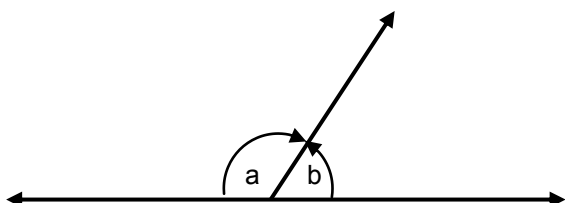
You learnt that „**adjacent**“ means „**next to**“ or „**beside**“, therefore, an angle which is next to or beside another angle is said to be an adjacent angle. We say the two angles are **adjacent**.

What are adjacent angles?

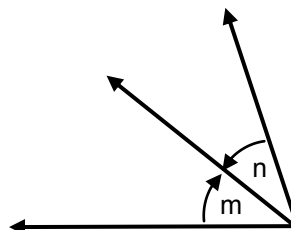


**Adjacent angles are two or more angles which are next to or beside each other and share a common vertex and a common side between them.**

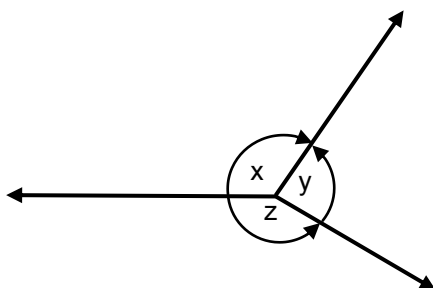
Here are some examples.



$\angle a$  and  $\angle b$  are adjacent angles.



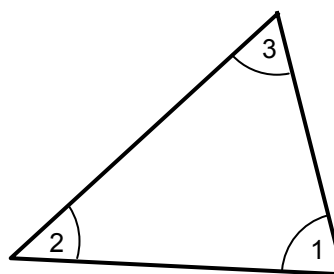
$\angle m$  and  $\angle n$  are adjacent angles.



$\angle x$  and  $\angle y$  are adjacent angles.

$\angle y$  and  $\angle z$  are adjacent angles.

$\angle x$  and  $\angle z$  are adjacent angles.

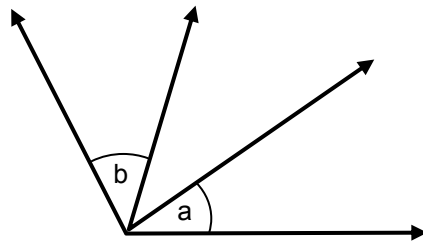


$\angle 1$  and  $\angle 2$  are adjacent interior angles.

$\angle 2$  and  $\angle 3$  are adjacent interior angles.

$\angle 1$  and  $\angle 3$  are adjacent interior angles.

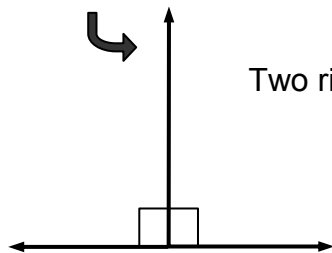
They are angles next to each other therefore they are called adjacent angles.



$\angle a$  and  $\angle b$  are **not** adjacent angles.

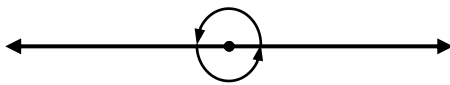
The angles share the vertex but do not share a common side and are not next to each other, therefore they are **not** adjacent angles.

Here are two right angles adjacent to each other. They make a straight angle.



Two right angles is  $2 \times 90^\circ = 180^\circ$

Here are two straight angles adjacent to each other. They make one revolution.



A straight angle is  $180^\circ$

Two straight angles is  $2 \times 180^\circ = 360^\circ$

**REMEMBER:**

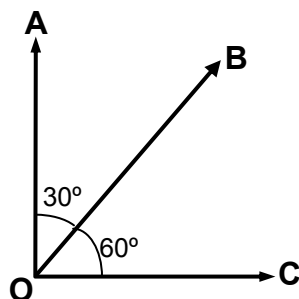
**Two adjacent right angles make a straight angle.**

**Two adjacent straight angles make a revolution.**



Now we will use the idea of adjacent angles.

Here are two adjacent angles.



The measure of  $\angle AOB = 30^\circ$ .

The measure of  $\angle COB = 60^\circ$

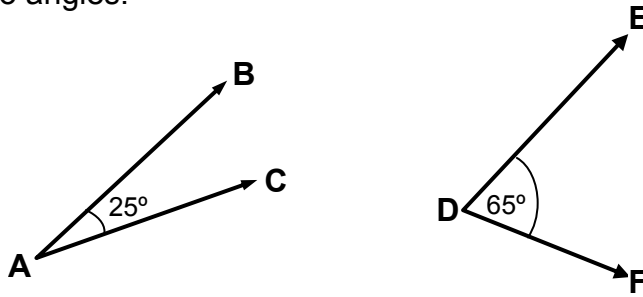
$$\angle AOB + \angle COB = 90^\circ$$

$\angle AOB + \angle COB$  are called adjacent complementary angles.

**Complementary angles are two angles whose sum is  $90^\circ$ .**

**Adjacent angles are complementary if they add up to  $90^\circ$  and form a right angle.**

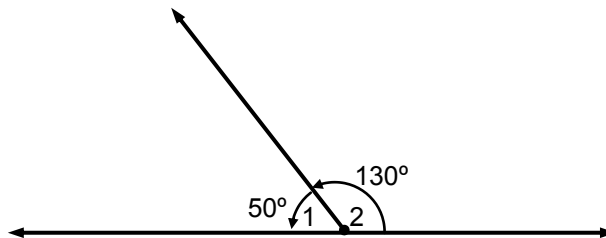
Look at the two angles.



$\angle BAC$  and  $\angle EDF$  are complementary angles,  
Because,  $\angle BAC + \angle EDF = 25^\circ + 65^\circ = 90^\circ$ .

We say,  $\angle BAC$  is the complement of  $\angle EDF$  and  $\angle EDF$  is the complement of  $\angle BAC$ .

Now look at these two adjacent angles.



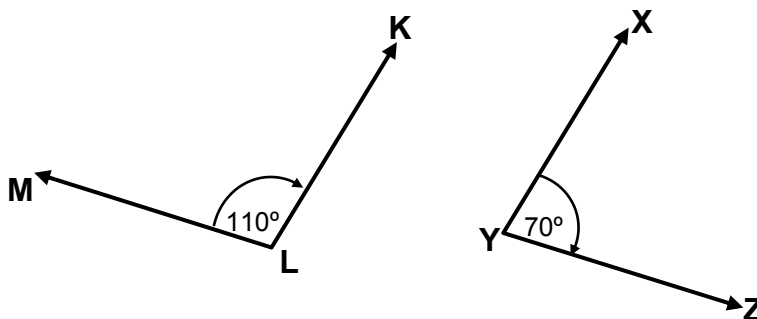
$$\angle 1 \text{ and } \angle 2 = 50^\circ + 130^\circ = 180^\circ$$

$\angle 1 + \angle 2$  share a common side. The angles are called adjacent supplementary angles.

**Supplementary angles are two angles whose sum is  $180^\circ$ .**

**Adjacent angles are supplementary if they add up to  $180^\circ$  and form a straight angle.**

Here are two angles.



$\angle KLM$  and  $\angle XYZ$  are supplementary angles  
Because,  $\angle KLM + \angle XYZ = 110^\circ + 70^\circ = 180^\circ$ .

We say,  $\angle KLM$  is the supplement of  $\angle XYZ$  and  $\angle XYZ$  is the supplement of  $\angle KLM$ .

**REMEMBER:**

**Two angles are complementary if their sum is equal to  $90^\circ$ .**

**In symbols,  $\angle 1 + \angle 2 = 90^\circ$**

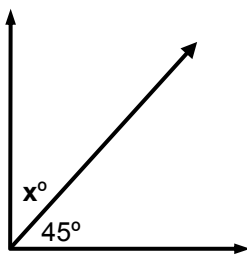
**Two angles are supplementary if their sum is equal to  $180^\circ$ .**

**In symbols,  $\angle 1 + \angle 2 = 180^\circ$**

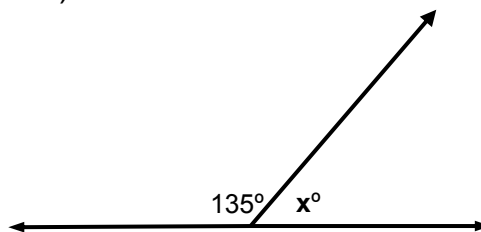
## Example 1

Find the value of  $x$  in each of the following.

a)



b)



Solutions:

$$\text{a) } x + 45^\circ = 90^\circ \text{ (adj. comp. } \angle\text{S)}$$

$$x = 90^\circ - 45^\circ$$

$$\text{Answer: } x = 45^\circ$$

$$\text{b) } x + 135^\circ = 180^\circ \text{ (adj. supp. } \angle\text{S)}$$

$$x = 180^\circ - 135^\circ$$

$$\text{Answer: } x = 45^\circ$$

## Example 2

Two angles are complementary. If the measure of one angle is  $52^\circ$ , what is the measure of the other angle?

Solution:

The two angles are complementary, so  $\angle 1 + \angle 2 = 90^\circ$

If we let  $\angle 1 = 52^\circ$

$$\text{Then, we have } 52^\circ + \angle 2 = 90^\circ$$

$$\angle 2 = 90^\circ - 52^\circ$$

$$\angle 2 = 38^\circ$$

**Answer: The measure of the other angle is  $38^\circ$ .**

## Example 3

The sum of three angles is  $180^\circ$ . The second angle is two times the first and the third is three times the first.

What are the angles?

Solution: The three angles are supplementary, so  $\angle 1 + \angle 2 + \angle 3 = 180^\circ$

If we let  $\angle 1 = x$ , then  $\angle 2 = 2x$  and  $\angle 3 = 3x$

By substitution, we have  $x + 2x + 3x = 180^\circ$

$$\text{Solve for } \angle 1: \quad x + 2x + 3x = 180^\circ$$

$$6x = 180^\circ$$

$$x = 30^\circ$$

$$\text{Solve for } \angle 2: \quad 2x = 2(30^\circ) = 60^\circ$$

$$\text{Solve for } \angle 3: \quad 3x = 3(30^\circ) = 90^\circ$$

**Answer:** The angles are  $30^\circ$ ,  $60^\circ$  and  $90^\circ$ .

(To check if the answer is correct, add all the three angles. They should sum up to  $180^\circ$ )

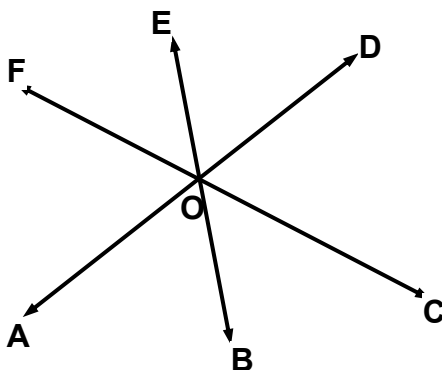
---

**NOW DO PRACTICE EXERCISE 1**



## Practice Exercise 1

1. Refer to the diagram to answer the following questions.



- a) Name three angles which are adjacent to  $\angle BOC$ .

**Answer:** \_\_\_\_\_, \_\_\_\_\_ and \_\_\_\_\_

- b) Name three angles which are adjacent to  $\angle BOA$ .

**Answer:** \_\_\_\_\_, \_\_\_\_\_ and \_\_\_\_\_

- c) Name three angles which are adjacent to  $\angle BOD$ .

**Answer:** \_\_\_\_\_, \_\_\_\_\_ and \_\_\_\_\_

2. Write down the sizes of the complement of the following angles.

a)  $30^\circ$  \_\_\_\_\_ b)  $25^\circ$  \_\_\_\_\_ c)  $5^\circ$  \_\_\_\_\_

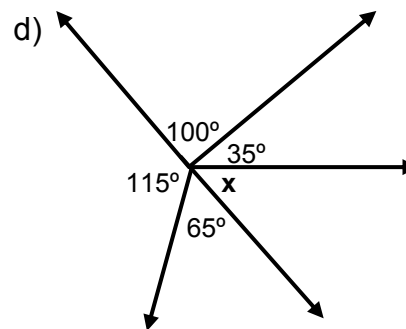
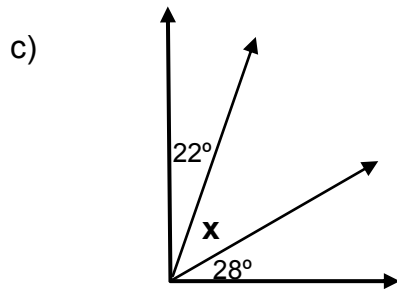
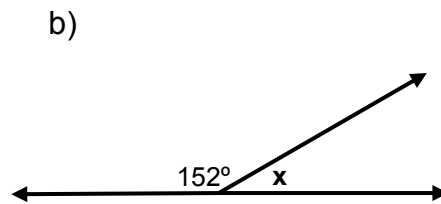
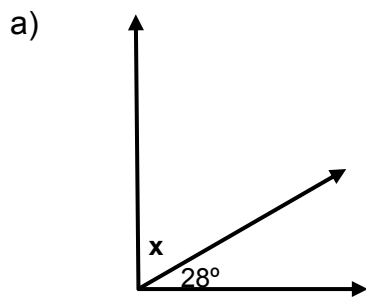
d)  $35^\circ$  \_\_\_\_\_ e)  $60^\circ$  \_\_\_\_\_ f)  $75^\circ$  \_\_\_\_\_

3. Write down the sizes of the supplement of the following angles.

a)  $118^\circ$  \_\_\_\_\_ b)  $60^\circ$  \_\_\_\_\_ c)  $80^\circ$  \_\_\_\_\_

d)  $45^\circ$  \_\_\_\_\_ e)  $15^\circ$  \_\_\_\_\_ f)  $75^\circ$  \_\_\_\_\_

4. Find the size of the angles marked  $x$ .



5. Solve the following:

a) Two angles are complementary. One is two-thirds of the other.

Find the angles.

**Answer:** \_\_\_\_\_, \_\_\_\_\_

b) Three angles are supplementary. The second angle is  $10^\circ$  more than the first and the third is  $10^\circ$  more than the second. Find the angles.

**Answer:** \_\_\_\_\_, \_\_\_\_\_, \_\_\_\_\_

**CHECK YOUR WORK. ANSWERS ARE AT THE END OF SUB-STRAND 1.**



## Lesson 2: Angles at a Point and Vertical Angles



You learnt to identify adjacent angles, complementary angles and supplementary angles in Lesson 1. You also learnt to work out the size of an unknown angle given its supplement and complement.



In this lesson, you will:

- define angles at a point and vertically opposite angles
- find the sum of the angles at a point and vertically opposite angles
- calculate the size of other unknown angles when one is given.

You learnt that the size of an angle is the amount of turning done by a moving arm when turning from the position of one arm of the angle to the position of the other arm.

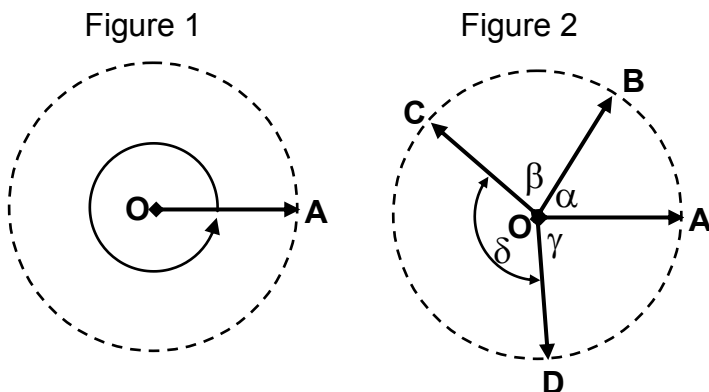
You also learnt that the unit for measuring angles is the degree which is represented by the symbol ( $^{\circ}$ ).

Here you will learn some more symbols used to represent the measure or size of an angle.

**The Greek letters  $\alpha$ ,  $\beta$ ,  $\gamma$ ,  $\delta$  and  $\theta$  are used to stand for the measure or size of an angle. This means that the degrees symbol is not used with them.**

These symbols are introduced for you to understand the angles at a point.

Look at the figures.

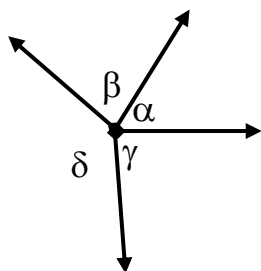


Here the arm **OA** can move around the fixed point **O**

In Figure 1, the arm **OA** completes one revolution and so moves through an angle of  $360^{\circ}$ .

In Figure 2, the arm **OA** stops at **B**, **C** and **D** before continuing to its starting position. Despite these stops, the arm **OA** has still completed one revolution.

Hence, we can see that:

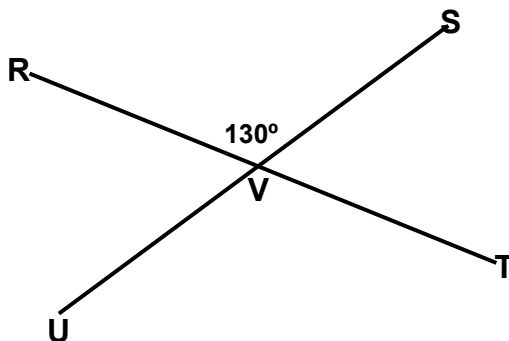


$$\alpha + \beta + \gamma + \delta = 360^\circ$$

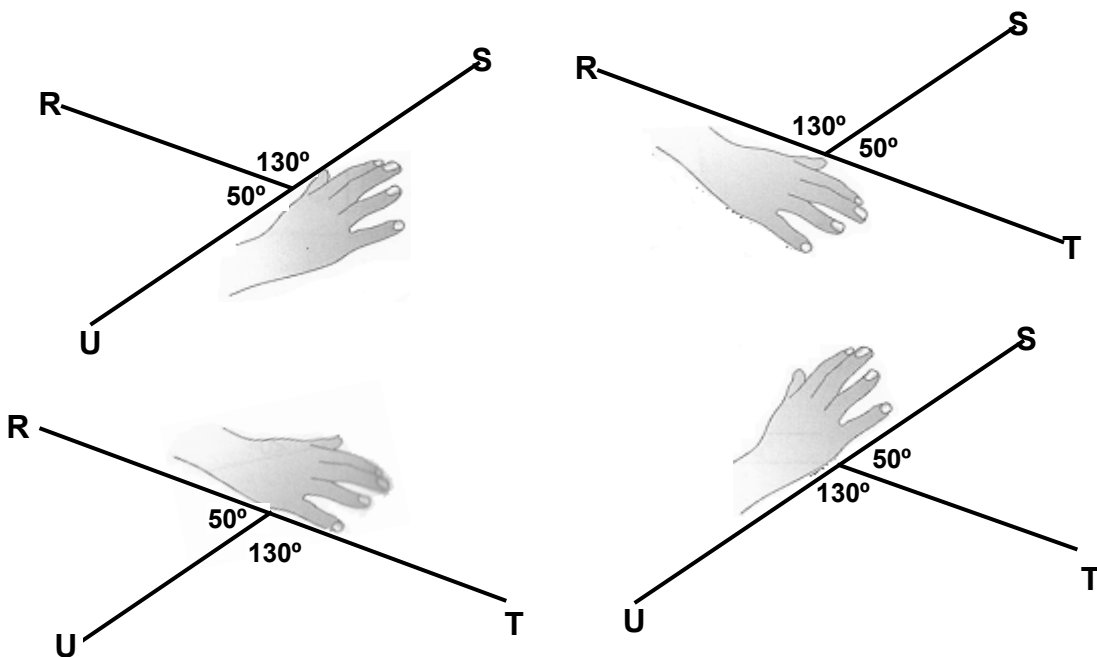
$\angle\alpha, \angle\beta, \angle\gamma$  and  $\angle\delta$  are called **angles at a point**.

**Angles at a point are angles that sum up to 1 revolution.**  
**1 revolution =  $360^\circ$**

Now look at the figure.

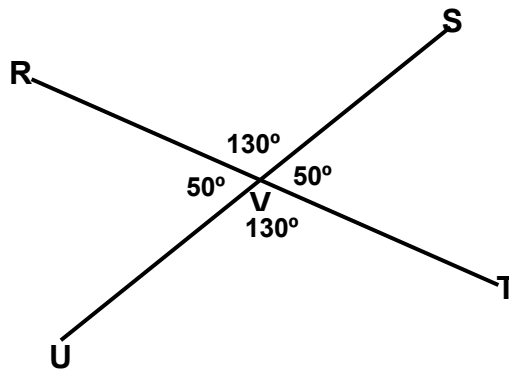


$\overline{RT}$  and  $\overline{SU}$  are straight lines and  $\angle SVR = 130^\circ$ . Using the knowledge learnt in the previous lessons, we can calculate or work out the size of the other three angles.



By progressively covering up each of the arms VT, VU, VS and VR, we get the series of diagrams above. Each of these diagrams shows a pair of adjacent supplementary angles.

Putting these results together, we can see that when two lines cross, two pairs of equal angles are formed. These angles which are opposite each other are called **vertically opposite angles**.



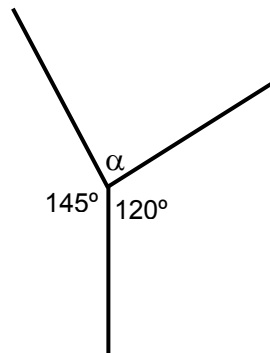
**When two straight lines cross or intersect, two pairs of vertically opposite angles are formed.**

**Vertically opposite angles are equal or Vertical angles are equal.**

Now look at the following examples.

Example 1

Find the value of the angle marked  $\alpha$ .



Solution: Using the idea of Angles at a point, we have,

$$\alpha + 145^\circ + 120^\circ = 360^\circ$$

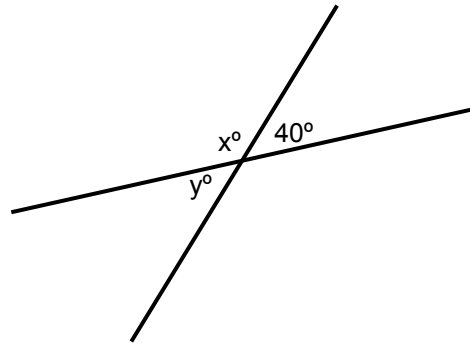
$$\alpha + 265^\circ = 360^\circ$$

$$\alpha = 360^\circ - 265^\circ$$

**Answer:  $\alpha = 95^\circ$**

## Example 2

Find the value of  $x$  and  $y$  in the diagram.



Solution: Using the idea of vertically opposite angles, we have

$$y = 40^\circ \quad (\text{vert. opp. } \angle\text{s})$$

$$x + 40^\circ = 180^\circ \quad (\text{adj, supp, } \angle\text{s})$$

$$x = 180^\circ - 40^\circ$$

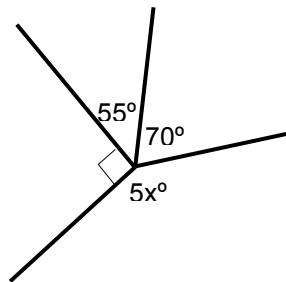
$$\text{Answer: } x = 140^\circ$$

$\angle$ S means „angles“.



## Example 3

Find the value of  $x$  in the diagram.



Solution:  $5x + 70^\circ + 55^\circ + 90^\circ = 360^\circ$  ( $\angle$ s at a point)

$$5x + 215^\circ = 360^\circ$$

$$5x = 360^\circ - 215^\circ$$

$$5x = 145^\circ$$

$$\text{Answer: } x = 29^\circ$$

**NOW DO PRACTICE EXERCISE 2**

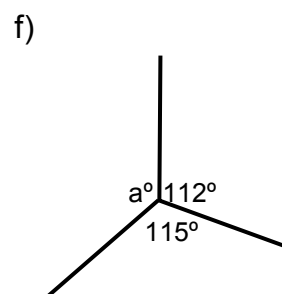
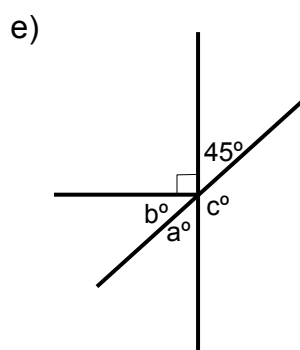
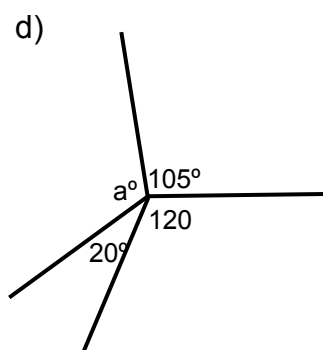
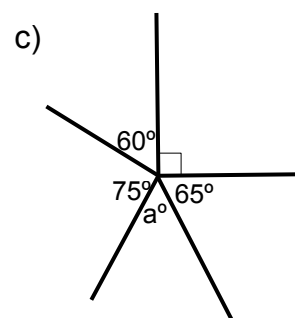
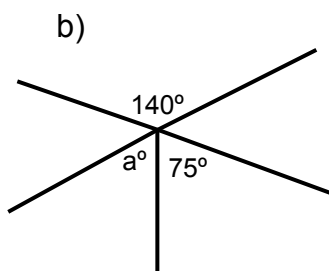
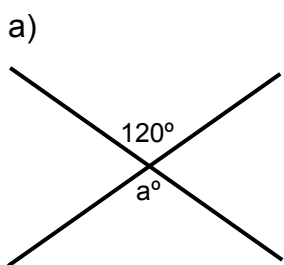


## Practice Exercise 2

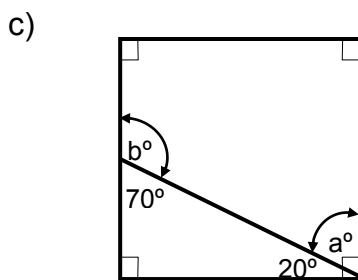
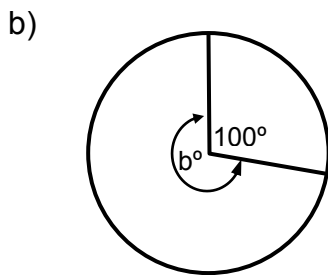
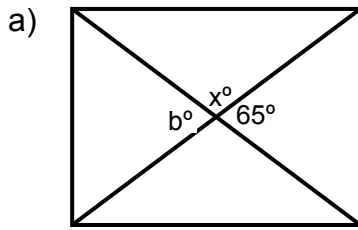
1. Complete the following statements by filling in the blank spaces with the correct word/words.

- When two lines cross, two pairs of \_\_\_\_\_ angles are formed. These angles which are \_\_\_\_\_ each other, are called \_\_\_\_\_.
- Angles at a point are angles equal to \_\_\_\_\_.
- A revolution equals \_\_\_\_\_ degrees.
- \_\_\_\_\_ lines form vertical angles.
- Vertical angles are \_\_\_\_\_.

2. Find the value of **missing angles** in each of the following.



3. Find the value of the pronumerals in each of the following.



**CORRECT YOUR WORK. ANSWERS ARE AT THE END OF SUB-STRAND 1.**

### Lesson 3: Angles formed by a Transversal



You learnt the meaning of angles at a point and vertically opposite angles in Lesson 2. You also learnt to find the unknown angles when some of the angles are given in Lesson 2.



In this lesson, you will:

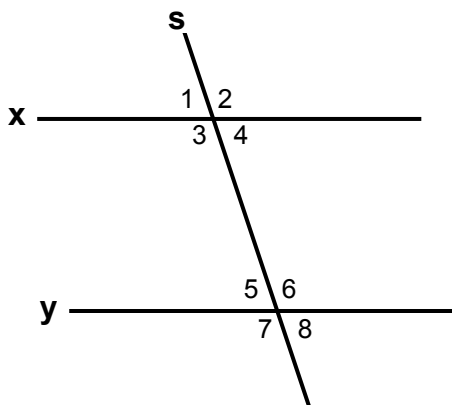
- identify parallel lines and a transversal
- identify and describe angles formed by a transversal
- show the relationship between angles formed by a transversal.

You learnt that parallel lines are lines that lie on the same plane but never meet however far they are extended.

Now, you are going to learn about angles associated with parallel lines.

When two lines are cut by a third line at different points, this line is called a **transversal** of the two lines.

Study the figure.



In the figure, When Line **x** and Line **y** are cut by the transversal **s**, the eight angles shown are formed. With Line **x**, the angles formed are  $\angle 1$ ,  $\angle 2$ ,  $\angle 3$  and  $\angle 4$ . With Line **y**, the angles formed are  $\angle 5$ ,  $\angle 6$ ,  $\angle 7$  and  $\angle 8$ .

From what we have learnt about vertically opposite angles, we can see that:

$$\angle 2 = \angle 3 \quad \angle 6 = \angle 7 \quad \angle 5 = \angle 8 \quad \angle 1 = \angle 4$$

Look at  $\angle 2$  and  $\angle 6$ . These angles are on the same side of the transversal and above the lines **x** and **y**.  $\angle 2$  and  $\angle 6$  are called **corresponding angles**.  $\angle 4$  and  $\angle 8$  are also on the same side of the transversal although they are below lines **x** and **y**. These angles are also called corresponding angles.

Using the same notation about vertically opposite angles, we can see that when two parallel lines are cut by a transversal, then **four pairs of corresponding angles are equal**.

Hence,  $\angle 1 = \angle 5 \quad \angle 2 = \angle 6 \quad \angle 3 = \angle 7 \quad \angle 4 = \angle 8$

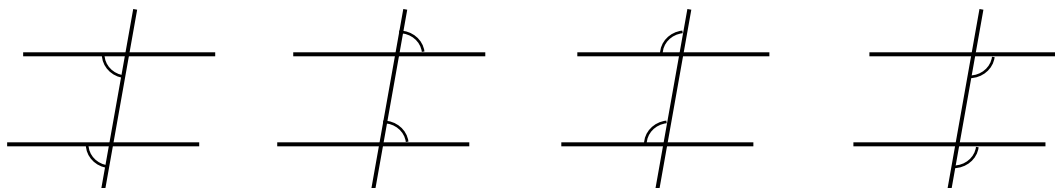
This means that:  $\angle 1, \angle 4, \angle 5, \angle 8$  are equal; and

$\angle 2, \angle 3, \angle 6, \angle 7$  are equal

We give special names to certain pairs of angles formed when a transversal cuts or intersects two lines.

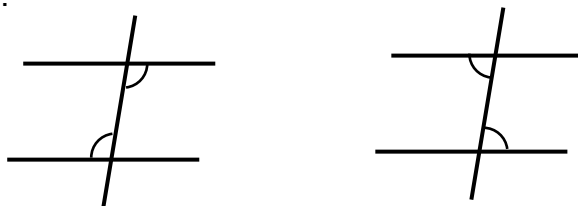
The special relationships that occur when two lines are parallel are set out in the following rules.

- When a pair of parallel lines is cut by a transversal, four pairs of **corresponding angles** are formed.



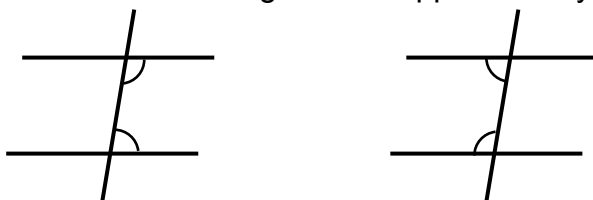
**Corresponding angles are pairs of angles, one exterior and one interior angle on the same side of the transversal and not adjacent.**

- When a pair of parallel lines is cut by a transversal, two pairs of equal **alternate angles** are formed.



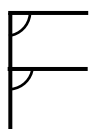
**Alternate angles are pairs of interior angles on the opposite side of the transversal and not adjacent.**

- When a pair of parallel lines is cut by a transversal, two pairs of **co-interior angles** are formed. Co-interior angles are supplementary.

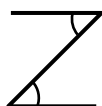


**Co-interior angles are two interior angles at the same side of a transversal.**

You should learn to recognize pairs of corresponding, alternate and co-interior angles. Drawing the 3 blocks of letters **F**, **Z** and **U** will help you to remember these angles.



corresponding



alternate



Co-interior



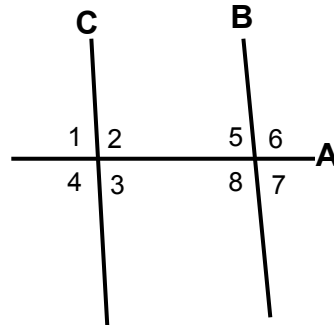
You can get the „shapes“ of the 3 types of angle pairs by rotating or turning over the three „letter shapes“.

Now look at the examples.

### Example 1

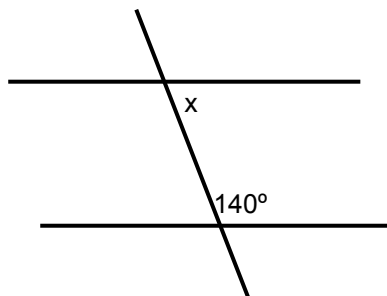
In the diagram:

- Line **A** is the transversal
- $\angle 5$  is co-interior to  $\angle 2$
- $\angle 3$  is co-interior to  $\angle 8$
- $\angle 5$  is alternate to  $\angle 3$
- $\angle 8$  is alternate to  $\angle 2$
- $\angle 5$  is corresponding to  $\angle 1$
- $\angle 3$  is corresponding to  $\angle 7$



### Example 2

Find the value of  $x$  in the diagram by identifying corresponding, alternate or co-interior angles.



Solution: Co-interior angles are supplementary.

$$\text{Therefore, } x + 140^\circ = 180^\circ$$

$$x = 180^\circ - 140^\circ$$

$$x = 40^\circ$$

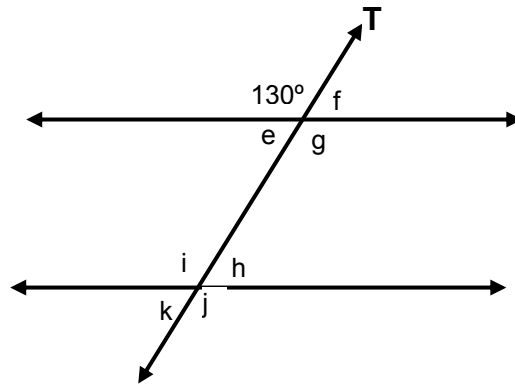
**Answer:  $x = 40^\circ$**

Supplementary angles  
add up to  $180^\circ$ .



## Example 3

Find the angles **e**, **f**, **g**, **h**, **i**, **j** and **k** in the diagram.



- Solution;
- $\angle g = 130^\circ$  (because  $\angle g$  and  $130$  are vertically opposite angles)
  - $\angle e = 50^\circ$  (because  $\angle e$  and  $130$  are supplementary)
  - $\angle f = 50^\circ$  (because  $\angle e$  and  $\angle f$  are vertically opposite  $\angle$ s)
  - $\angle h = 50^\circ$  ((because the two pairs of vertically opposite  $\angle$ s are =)
  - $\angle k = 50^\circ$  (because the two pairs of vertically opposite  $\angle$ s are =)
  - $\angle j = 130^\circ$  (because the two pairs of vertically opposite  $\angle$ s are =)
  - $\angle i = 130^\circ$  (because the two pairs of vertically opposite  $\angle$ s are =)

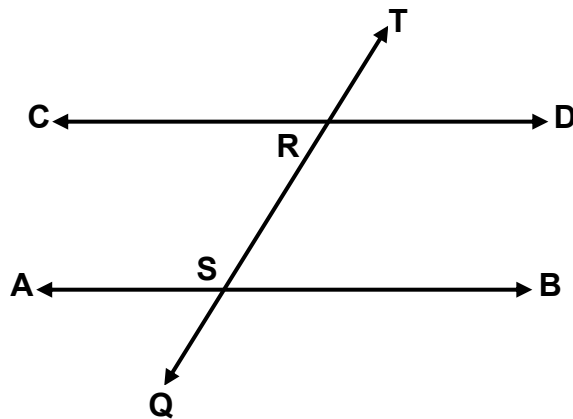
---

**NOW DO PRACTICE EXERCISE 3**



### Practice Exercise 3

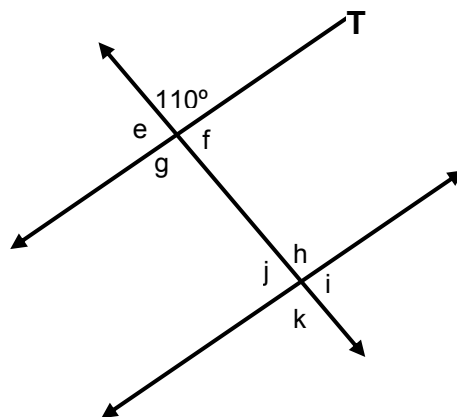
1) In the diagram,



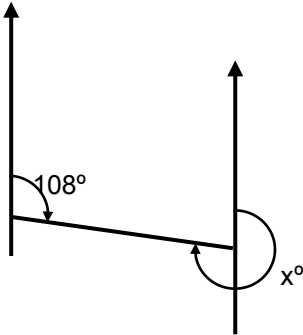
- |    |   |               |
|----|---|---------------|
| a) | Name the transversal.                         | Answer: _____ |
| b) | Name an angle corresponding to $\angle TRD$ . | Answer: _____ |
| c) | Name an angle corresponding to $\angle SRD$ . | Answer: _____ |
| d) | Name an angle alternate to $\angle CRS$ .     | Answer: _____ |
| e) | Name an angle alternate to $\angle SRD$ .     | Answer: _____ |
| f) | Name an angle co-interior to $\angle SRD$ .   | Answer: _____ |
| g) | Name an angle co-interior to $\angle CRS$ .   | Answer: _____ |

2. Find the value of each angle marked with a letter in each of the following diagrams.

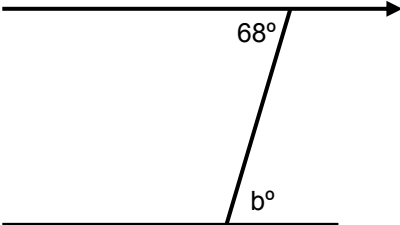
a)



b)



c)



---

**CORRECT YOUR WORK. ANSWERS ARE AT THE END OF SUB-STRAND 1.**

## Lesson 4: Angle Sum of a Triangle



You identified parallel lines and a transversal and described the relationship between the angles formed by a transversal in Lesson 3.



In this lesson, you will:

- find the measure of each angle of a triangle and develop a rule for finding the sum of the angles
- discuss the relationship between the exterior and the interior angles of a triangle
- work out the size of the exterior angle of a triangle
- find that the sum of the angles of a triangle add up to 180 degrees

In Grade 7, you learnt that the angles of a triangle add up to 180 degrees. This was done by cutting the angles of a triangle and rearranging them to form a straight angle.

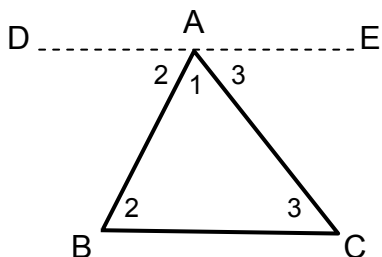
Look at the diagram on how this was done.



Draw any acute triangle on paper, and carefully cut it out. Label the corners 1, 2, 3 as shown, and cut them off. Put them together testing the lower edge with a ruler.

The work that was performed suggests a property of every triangle.

This can be proven by first drawing a line



First you draw a line DE through A parallel to BC.

$$\angle BAD = \angle 2 \text{ (alternate to } \angle ABC, DE \parallel BC)$$

$$\angle CAE = \angle 3 \text{ (alternate to } \angle ACB, DE \parallel BC)$$

$$\text{Now, } \angle 1 + \angle 2 + \angle 3 = 180^\circ \text{ (} \angle DAE \text{ is a straight } \angle)$$

// means parallel.



Therefore,

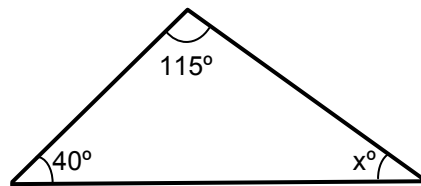
**The angle sum of any triangle is 180 degrees.**

**In symbols,  $\angle 1 + \angle 2 + \angle 3 = 180^\circ$**

This means that if you know two angles of a triangle, you can find the third angle.

Example 1

Find the unknown angle marked  $x^\circ$ .



Solution:

In the triangle, the known angles  $40^\circ$  and  $115^\circ$  add up to  $155^\circ$ .

By the angle sum of a triangle, we have

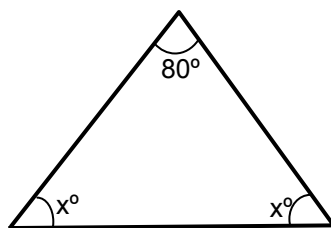
$$x^\circ + 155^\circ = 180^\circ$$

$$x^\circ = 180^\circ - 155^\circ \quad (\text{subtract } 155^\circ \text{ on both sides})$$

$$\text{Therefore, } x^\circ = 25^\circ$$

Example 2

Find the value of the angles marked  $x^\circ$ , giving reason for your answers.



Solution:

$$x^\circ + x^\circ + 80^\circ = 180^\circ \quad (\text{angle sum of a triangle})$$

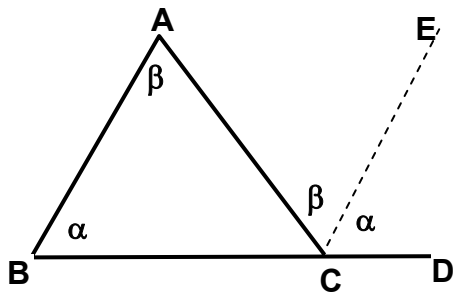
$$\text{So, } 2x^\circ + 80^\circ = 180^\circ$$

$$2x^\circ = 180^\circ - 80^\circ \quad (\text{Subtract } 80 \text{ on both sides})$$

$$2x^\circ = 100^\circ \quad (\text{Divide by } 2 \text{ on both sides})$$

$$\text{Therefore, } x^\circ = 50^\circ$$

Now look at the triangle below.



$\angle ACD$  is known as an exterior angle in the triangle.

We can find the relationship between the exterior angle  $ACD$  and others within the triangle.

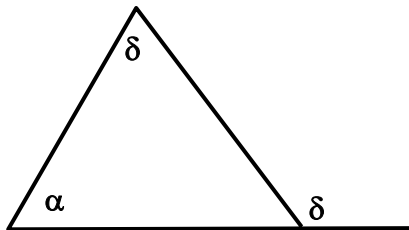
First, we draw a line  $EC$  through  $C$ , parallel to  $AB$ .

$$\angle ACE = \beta \text{ (alternate to } \angle BAC, AB \parallel EC)$$

$$\angle ECD = \alpha \text{ (corresponding to } \angle ABC, AB \parallel EC)$$

$$\text{Now, } \angle ACD = \alpha + \beta \text{ (} \angle ACD = \angle ACE + \angle ECD \text{)}$$

Therefore, the exterior angle of a triangle is equal to the sum of the interior (or remote) opposite angles.

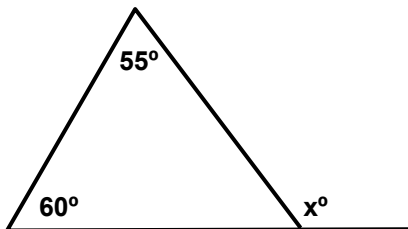


**The exterior angle of a triangle is equal to the sum of the two remote interior angles.**

$$\text{In symbol, } \angle \delta = \angle \alpha + \angle \beta$$

Find the size of the exterior angle  $x^\circ$  in the following diagrams.

Example 1



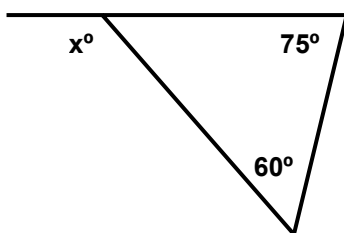
Solution:  $\angle x$  is the exterior angle of the  $\Delta$

$$x^\circ = 55^\circ + 60^\circ \text{ (ext. } \angle \text{ of a } \Delta)$$

$$x^\circ = 115$$

Therefore,  $x = 115^\circ$

Example 2



Solution:

$$x^\circ = 75^\circ + 60^\circ \text{ (ext. } \angle \text{ of a } \Delta)$$

$$x^\circ = 135$$

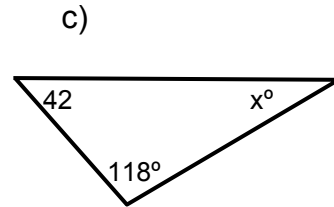
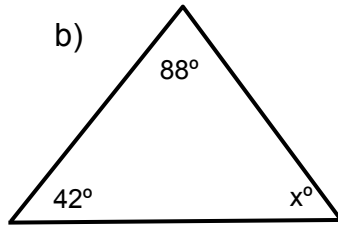
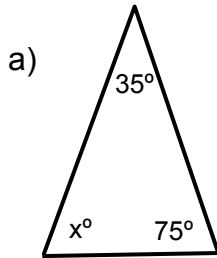
Therefore,  $x = 135^\circ$

**NOW DO PRACTICE EXERCISE 4**



## Practice Exercise 4

1. Find the value of the pronumeral in each of the following triangles.

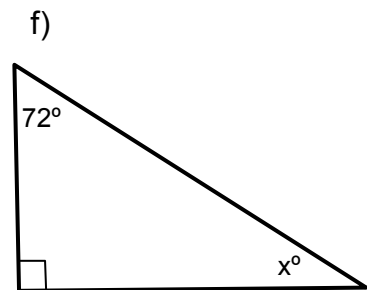
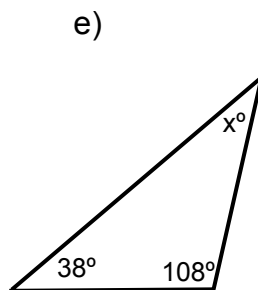
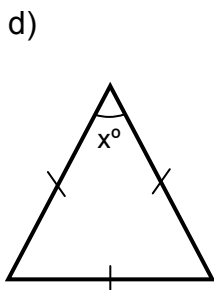


Working out:

Answer: \_\_\_\_\_

Answer: \_\_\_\_\_

Answer: \_\_\_\_\_



Working out:

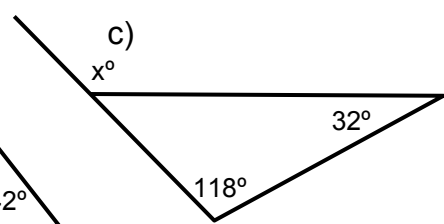
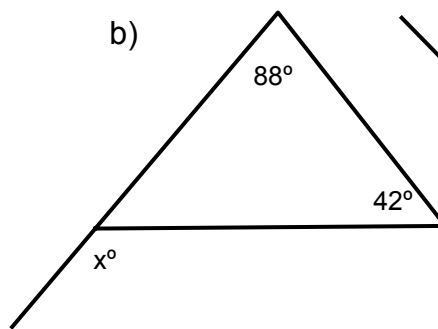
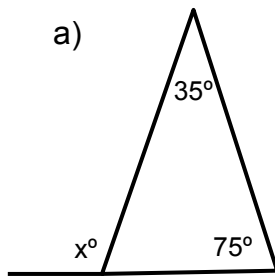
Answer: \_\_\_\_\_

Answer: \_\_\_\_\_

Answer: \_\_\_\_\_



2. Using the exterior angle properties of a triangle, find the size of the unknown angle  $x$  in the following triangles.

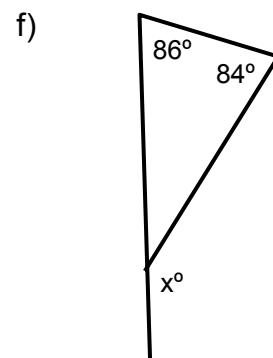
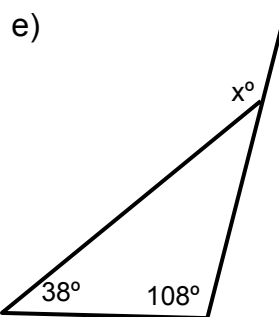
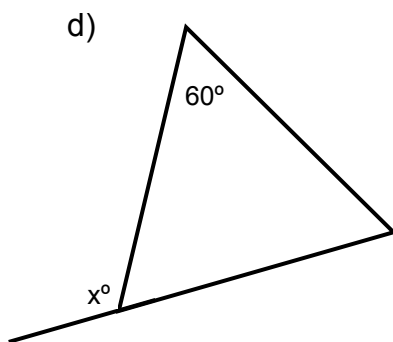


Working out:

Answer: \_\_\_\_\_

Answer: \_\_\_\_\_

Answer: \_\_\_\_\_



Working out:

Answer: \_\_\_\_\_

Answer: \_\_\_\_\_

Answer: \_\_\_\_\_

**CORRECT YOUR WORK. ANSWERS ARE AT THE END OF SUB-STRAND 1**

## Lesson 5: Angle Sum of a Quadrilateral



In Lesson 4, you learnt to find the measure of the interior angles of a triangle and formulate the rule to find the sum of the angles. You also discussed the relationship between the exterior angle and the interior angles of the triangle.



In this lesson, you will:

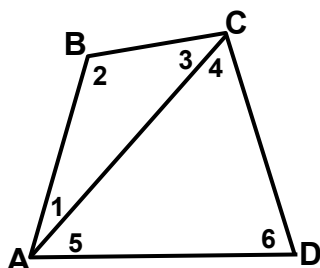
- determine the angle sum of a quadrilateral
- find the measure of an unknown angle in a given quadrilateral.

We proved that the angles of a triangle have a sum of  $180^\circ$  in the last lesson,

Since all quadrilaterals can be divided into two triangles, we can conclude that the angle sum of a quadrilateral is  $2 \times 180^\circ$  or  $360^\circ$ .

We can prove that the angle sum of a quadrilateral is  $360^\circ$ .

Look at the diagram.



$$\begin{aligned}
 \text{Angle sum of Quadrilateral } \mathbf{ABCD} &= \angle \mathbf{ABC} + \angle \mathbf{BCD} + \angle \mathbf{CDA} + \angle \mathbf{BAD} \\
 &= 2 + (3 + 4) + 6 + (5 + 1) \\
 &= (1 + 2 + 3) + (4 + 5 + 6) \\
 &= \text{angle sum of } \triangle \mathbf{ABC} + \text{angle sum of } \triangle \mathbf{CDA} \\
 &= 180^\circ + 180^\circ \\
 &= 360^\circ
 \end{aligned}$$

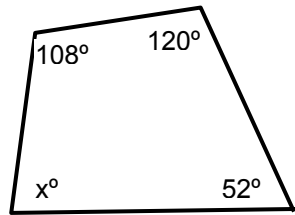
Therefore, the angle sum of the quadrilateral is  $360^\circ$

**The angles of a quadrilateral add up to 360 degrees.**

**In symbol,  $\angle A + \angle B + \angle C + \angle D = 360^\circ$**

## Example 1

Find the value of the pronumeral  $x$  in the diagram.



Solution:

Use the angle sum property for quadrilateral

$$\angle A + \angle B + \angle C + \angle D = 360^\circ$$

By substitution  $x + 52^\circ + 120^\circ + 108^\circ = 360^\circ$

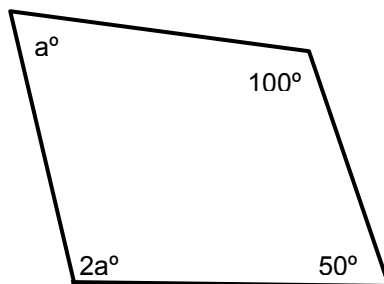
$$x + 280^\circ = 360^\circ$$

$$x = 360^\circ - 280^\circ$$

Therefore,  $x = 80^\circ$

## Example 2

Work out the unknown angle in the diagram by finding the value of  $a$ .



Solution:

$$a + 2a + 100^\circ + 50^\circ = 360^\circ \quad (\text{angle sum of a quadrilateral})$$

$$3a + 150^\circ = 360^\circ$$

$$3a = 360^\circ - 150^\circ$$

$$3a = 210^\circ$$

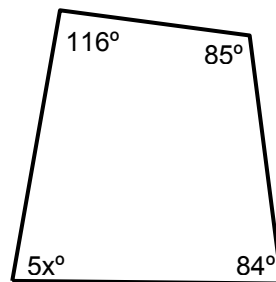
$$a = 70^\circ$$

So,  $2a = 2 \times 70 = 140^\circ$

Therefore, the missing angles are  $70^\circ$  and  $140^\circ$ .

## Example 3

Write an equation for the angle sum of the quadrilateral below and solve it to find the value of the missing angle in degrees.



Solution:

Form the equation:  $5x^\circ + 116^\circ + 85^\circ + 84^\circ = 360^\circ$  (angle sum of quadrilateral)

Solve the equation to find  $x$ .  $5x + 285^\circ = 360^\circ$

$$5x = 360^\circ - 285^\circ$$

$$5x = 75^\circ$$

$$x = 15^\circ$$

Therefore, the value of the missing angle is  $5x = 5(15) = 75^\circ$ .

## Example 4

Use the angle sum of the quadrilateral ABCD to find the value of  $x$  and then find the value of  $y$ .

Solution:

a) Solve for  $x$ .

$$x + 90^\circ + 130^\circ + 70^\circ = 360^\circ \quad (\angle \text{ sum of a quadrilateral})$$

$$x + 290^\circ = 360^\circ$$

$$x = 360^\circ - 290^\circ \quad (\text{subtract } 290 \text{ on both sides})$$

$$x = 70^\circ$$

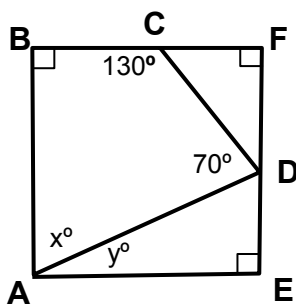
b) Solve for  $y$ .

$$y + x = 90^\circ \quad (\text{adjacent complementary } \angle\text{s})$$

$$y + 70^\circ = 90^\circ$$

$$y = 90^\circ - 70^\circ \quad (\text{subtract } 70 \text{ on both sides})$$

$$y = 20^\circ$$

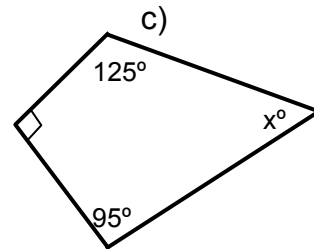
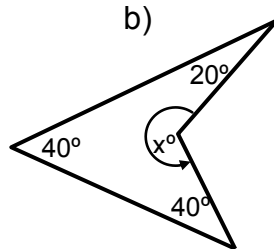
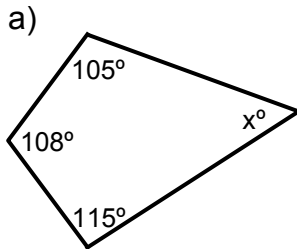


NOW DO PRACTICE EXERCISE 5



## Practice Exercise 5

1. Find the value of the angle marked  $x$  in each of the following diagrams.

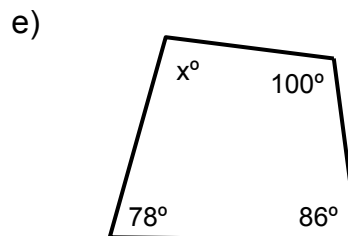
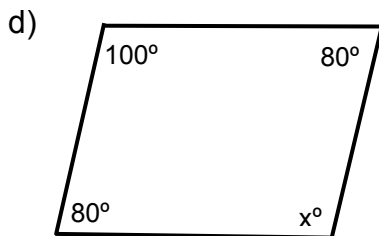


Working out:

Answer: \_\_\_\_\_

Answer: \_\_\_\_\_

Answer: \_\_\_\_\_



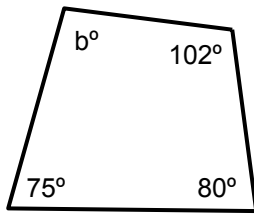
Working out:

Answer: \_\_\_\_\_

Answer: \_\_\_\_\_

2. Write an equation for the angle sum of each of the following quadrilaterals and then solve it to find the value of **b**.

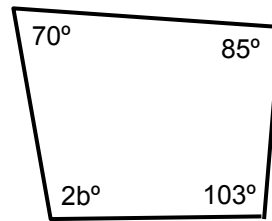
a)



Working out:

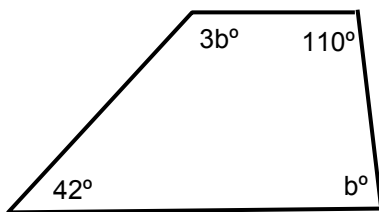
Answer: \_\_\_\_\_

b)



Answer: \_\_\_\_\_

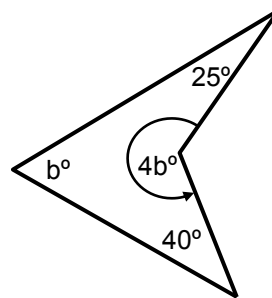
c)



Working out:

Answer: \_\_\_\_\_

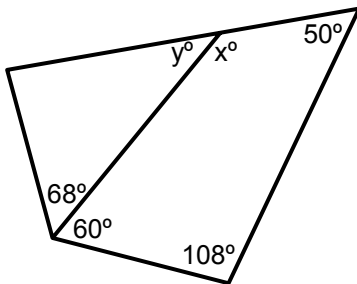
d)



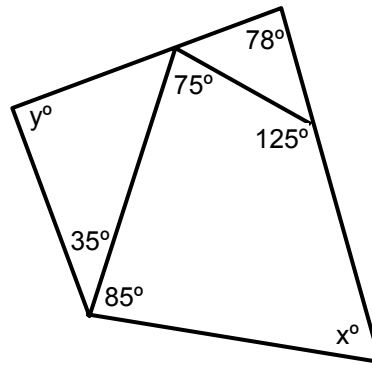
Answer: \_\_\_\_\_

3. Use the angle sum property of Quadrilateral ABCD to find the value of  $x$  and then find the value of  $y$ .

a)



b)



Working out:

Answer: \_\_\_\_\_

Answer: \_\_\_\_\_

---

**CORRECT YOUR WORK. ANSWERS ARE AT THE END OF SUB-STRAND 1.**

## Lesson 6: Isosceles and Equilateral Triangle



You learnt to work out the angle sum of a quadrilateral and find the measure of an unknown angle in a given quadrilateral in Lesson 5.

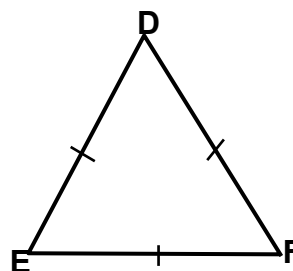
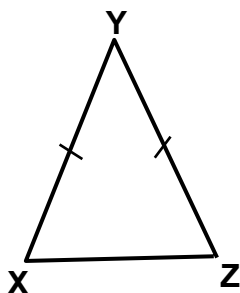
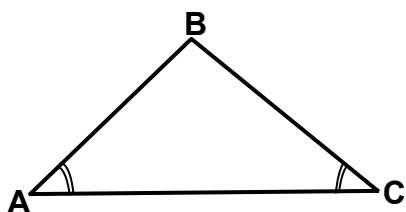


In this lesson, you will:

- revise the meaning of an isosceles and an equilateral triangle
- calculate the unknown angle of an isosceles and an equilateral triangle given in a diagram.

You learnt the meanings of isosceles and equilateral triangles and some of their properties in Grade 7. Now you will learn and extend your knowledge about these two triangle types.

Look at these triangles.



Which of the triangles are isosceles?

Which of the triangles are equilateral?

In  $\triangle XYZ$ , which angles are equal?

In  $\triangle ABC$ , which sides are equal?

These questions will remind you of the properties of isosceles and equilateral triangles.

**In an isosceles triangle;**

- **Two sides (legs) are equal.**
- **Base angles are equal.**

**In an equilateral triangle;**

- **Three sides are equal**
- **Three angles are equal and each angle measures 60 degrees.**

Therefore,  $\triangle XYZ$  and  $\triangle ABC$  are isosceles triangles.

$\triangle DEF$  is an equilateral triangle.

In  $\triangle XYZ$ ,  $\angle X$  and  $\angle Z$  are equal angles.

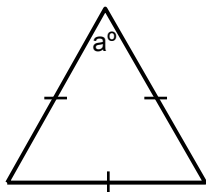
In  $\triangle ABC$ , sides  $AB$  and  $BC$  are equal sides.



We can find the size of an unknown angle of a triangle using the properties of isosceles and equilateral triangles.

### Example 1

Find the value of  $a$  in the following triangle giving reasons for your answer.

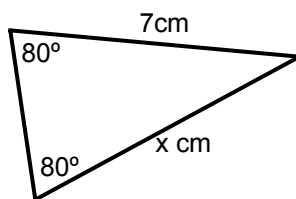


**Solution:** Since the triangle is equilateral, the three interior angles of the triangles are equal to 60 degrees.

Therefore,  $a = 60^\circ$  (interior  $\angle$  of an equilateral  $\Delta$ )

### Example 2

Find the value of  $x$  in the following triangle giving reasons for your answer.

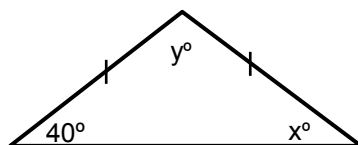


**Solution:** Since the base angles of the triangle are equal, we say the triangle is isosceles.

Therefore,  $x = 7 \text{ cm}$ . (2 legs of isosceles  $\Delta$  are equal)

### Example 3

Find the values of  $x$  and  $y$  in the following triangle giving reasons for your answer.



**Solution:**  $x = 40^\circ$  (base angles of isosceles  $\Delta$  are equal)

$$y^\circ + x^\circ + 40^\circ = 180^\circ \quad (\angle \text{ sum of triangle} = 180^\circ)$$

$$y + 40^\circ + 40^\circ = 180^\circ \quad (\text{substitute } x = 40)$$

$$y = 180^\circ - 80^\circ \quad (\text{solve for } y)$$

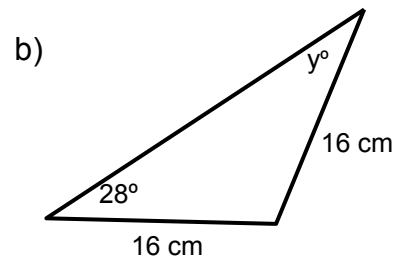
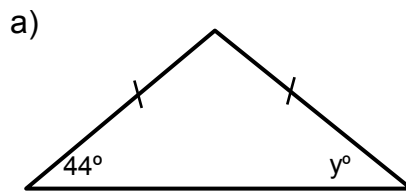
$$y = 100^\circ$$

**NOW DO PRACTICE EXERCISE 6**



## Practice Exercise 6

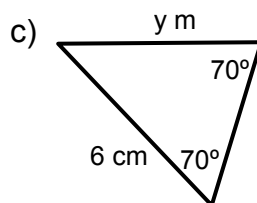
1. Find the value of  $y$  in the following triangles. Give reasons for your answers.



Working out:

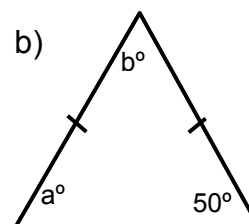
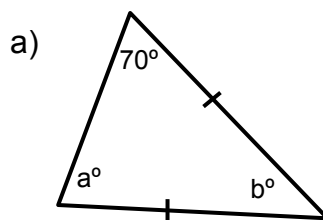
**Answer:** \_\_\_\_\_

**Answer:** \_\_\_\_\_



**Answer:** \_\_\_\_\_

2. Find the value of the pronumerals in the following triangles using the properties of isosceles and equilateral triangles.

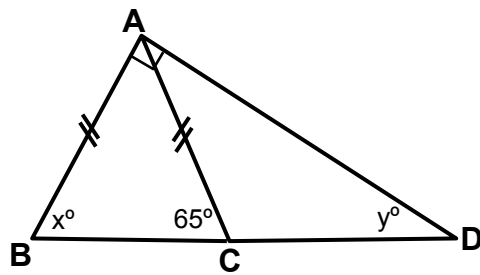


Working out:

**Answer:** \_\_\_\_\_

**Answer:** \_\_\_\_\_

3. Find the value of  $x$  and  $y$  in the diagram below.



Working out:

Answer: \_\_\_\_\_

---

**CORRECT YOUR WORK. ANSWERS ARE AT THE END OF SUB-STRAND 1.**

**SUB-STRAND 1: SUMMARY**

---



*This summarises some important terms and ideas for you to remember.*

- **Adjacent angles** are angles that have the same vertex and a common side between them.
- **Complementary angles** are two angles that add up to  $90^\circ$ .
- The **complement angle** is the angle that needs to be added to a given angle to add up to  $90^\circ$ .
- **Supplementary angles** are two angles that add up to  $180^\circ$ .
- The **supplement angle** is the angle that needs to be added to a given angle to add up to  $180^\circ$ .
- Angles at a point add up to  $360^\circ$ .
- **Vertically opposite angles** are pairs of equal angles formed by two intersecting straight lines.
- **Parallel lines** are two straight lines in the same plane that do not meet.
- A **transversal** is a line that cuts or crosses two or more other lines.
- **Corresponding angles** are pairs of angles, one exterior and one interior at the same side of the transversal and not adjacent.
- **Alternate angles** are pairs of interior angles on the opposite side of the transversal and not adjacent.
- **Co-interior angles** are two interior angles on the same side of a transversal.
- The angle sum of any triangle is 180 degrees.

$$\angle 1 + \angle 2 + \angle 3 = 180^\circ$$

- The angle sum of a quadrilateral is 360 degrees.

$$\angle A + \angle B + \angle C + \angle D = 360^\circ$$

- In an isosceles triangle;
    - Two sides (legs) are equal.
    - Base angles are equal.
  - In an equilateral triangle;
    - Three sides are equal
    - Three angles are equal and each angle measures 60 degrees.
- 

**REVISE LESSONS 1- 6 THEN DO SUB-STRAND TEST 1 IN ASSIGNMENT 1.**

**ANSWERS TO PRACTICE EXERCISES 1- 6**

---

**Practice Exercise 1**

1. a)  $\angle COD, \angle COE, \angle COF$   
b)  $\angle AOF, \angle AOE, \angle AOD$   
c)  $\angle DOE, \angle DOF, \angle DOA$
  2. a)  $60^\circ$                       d)  $55^\circ$   
b)  $65^\circ$                       e)  $30^\circ$   
c)  $85^\circ$                       f)  $15^\circ$
  3. a)  $62^\circ$                       d)  $135^\circ$   
b)  $120^\circ$                      e)  $165^\circ$   
c)  $100^\circ$                      f)  $105^\circ$
  4. a)  $62^\circ$                      b)  $28^\circ$                      c)  $40^\circ$                      d)  $45^\circ$
  5.  $54^\circ$  and  $36^\circ$
  6.  $50^\circ, 60^\circ$  and  $70^\circ$
- 

**Practice Exercise 2**

1. a) equal, opposite, vertically opposite angles  
b) 1 revolution  
c)  $360^\circ$   
d) Intersecting  
e) equal
  2. a)  $120^\circ$                       d)  $115^\circ$   
b)  $65^\circ$                       e)  $a = 45^\circ, b = 45^\circ, c = 135^\circ$   
c)  $70^\circ$                       f)  $133^\circ$
  3. (a)  $x = 115^\circ, b = 65^\circ$     (b)  $b = 260^\circ$             (c)  $a = 70^\circ, b = 110^\circ$
- 

**Practice Exercise 3**

1. a) Line TQ                    d)  $\angle BSR$                     g)  $\angle ASR$   
b)  $\angle RSB$                     e)  $\angle ASR$   
c)  $\angle QSB$                     f)  $\angle BSR$

2. a)  $e = 70^\circ, f = 70^\circ, g = 110^\circ, h = 110^\circ, i = 70^\circ, j = 70^\circ, k = 110^\circ$   
b)  $x = 288^\circ$   
c)  $b = 68^\circ$
- 

**Practice Exercise 4**

1. a)  $70^\circ$                       c)  $20^\circ$                       e)  $34^\circ$   
b)  $50^\circ$                       d)  $60^\circ$                       f)  $18^\circ$
2. a)  $110^\circ$                       c)  $150^\circ$                       e)  $146^\circ$   
b)  $130^\circ$                       d)  $118^\circ$                       f)  $170^\circ$
- 

**Practice Exercise 5**

1. a)  $32^\circ$                       b)  $260^\circ$                       c)  $50^\circ$   
d)  $100^\circ$                       e)  $96^\circ$
2. a)  $103^\circ$                       b)  $51^\circ$                       c)  $52^\circ$                       d)  $59^\circ$
3. a)  $x = 142^\circ; y = 38^\circ$   
b)  $x = 75^\circ; y = 87^\circ$
- 

**Practice Exercise 6**

- 1) a)  $y = 44^\circ$                       (base  $\angle$ s of isosceles  $\Delta$  are equal)  
b)  $y = 28^\circ$                       (base  $\angle$ s of isosceles  $\Delta$  are equal)  
c)  $y = 6\text{cm}$                       (two legs of isosceles  $\Delta$  are equal)
2. a)  $a = 70^\circ; y = 40^\circ$   
b)  $a = 50^\circ; y = 80^\circ$
3.  $x = 65^\circ; y = 25^\circ$
- 

<b>END OF SUB-STRAND 1</b>
----------------------------



## **SUB-STRAND 2**

### **CIRCLES**

**Lesson 7: What is a Circle?**

**Lesson 8: Parts of a Circle**

**Lesson 9: Naming Parts of a Circle**

**Lesson 10: Circumference of a Circle**

**Lesson 11: The Number Pii ( $\pi$ )**

**Lesson 12: Solving Problems involving Circumference**



## SUB-STRAND 2: CIRCLES

---

### Introduction



This is Sub-strand 2 of Grade 8 Mathematics Strand 2. In this Sub-strand, you will study circles and their properties.

From the earliest times the circle has fascinated people around the world. The sun and moon (both apparently are shaped like circles) have been worshipped. From early Greek times the circle has been studied and now the position on the earth's surface is described in terms of intersecting circles.

Below are photographs of some common objects. Do you recognize them?



Each object has a part that is circular in shape. Shape in an object meets a specific purpose. Can you tell why the rim of a cup is a circle? Why the plugs and manhole covers are round? Why bottoms of pans are circular?

The circle is the most symmetric of all mathematical curves. A circle can be turned on its centre through any angle and will still fit into its original position.

In this sub-strand, you will learn more about the circle and its properties. You will make models of circles and investigate their properties.

# Lesson 7: What is a Circle?



In the previous lessons, you learnt about the meanings and the different properties of plane shapes such as triangles, quadrilaterals and other polygons.



In this lesson, you will:

- define the circle
- differentiate circles from other plane shapes.

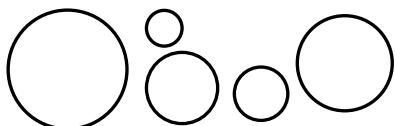
The circle is one of the most useful shapes and is sometimes considered the most beautiful one.

What is a circle?



Look at the shapes below.

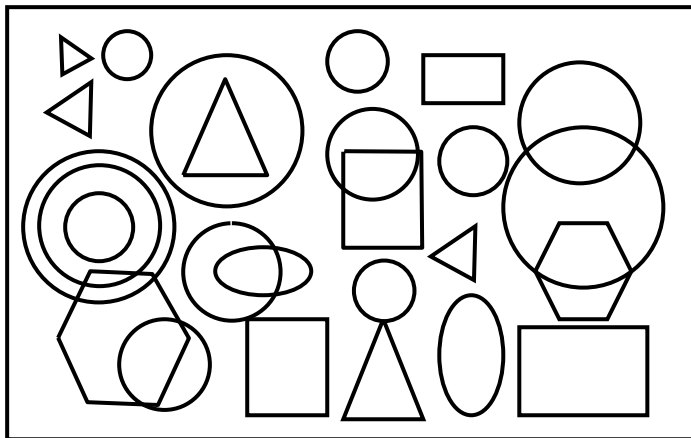
These are all circles.



These are **not** circles.



Look at this diagram. How many circles can you see?



Did you find 13 circles?

Look around you and identify objects which are circular in shape and make use of them.



I can see cars. The wheels of cars are in the shape of a circle.



These tins I bought at the store have circular lids.



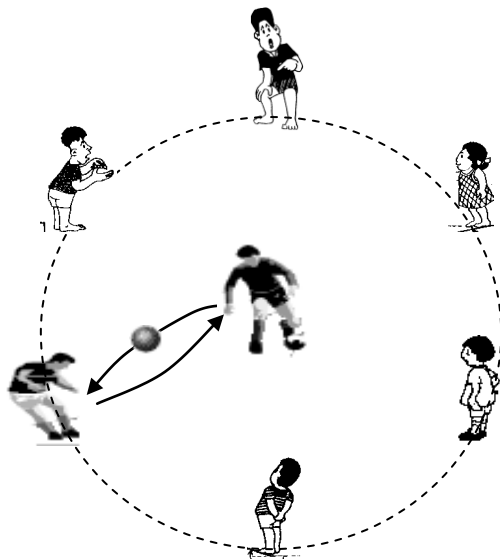
**NEW WORD:**

**Circular is something that is in the shape of a circle.**

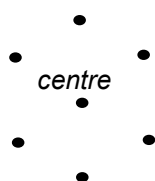
Now that you know what circles look like let us describe them in words.

**A circle is a closed figure on a plane (flat surface), all points of which are the same distance away from a fixed point within called the centre.**

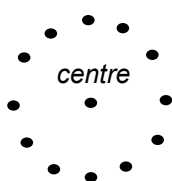
Here is a diagram that will help you to understand what a circle is.



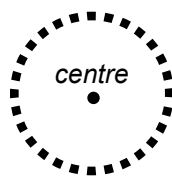
The players are standing the same distance away from a central player. The player in the centre throws the ball the same distance to each player. The central player marks the point at the centre of the circle. The other players are marking points on the circle.



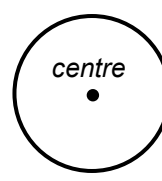
6 points are marked on the circle



12 points are marked on the circle



many points are marked on the circle



all points are marked on the circle

**REMEMBER:**

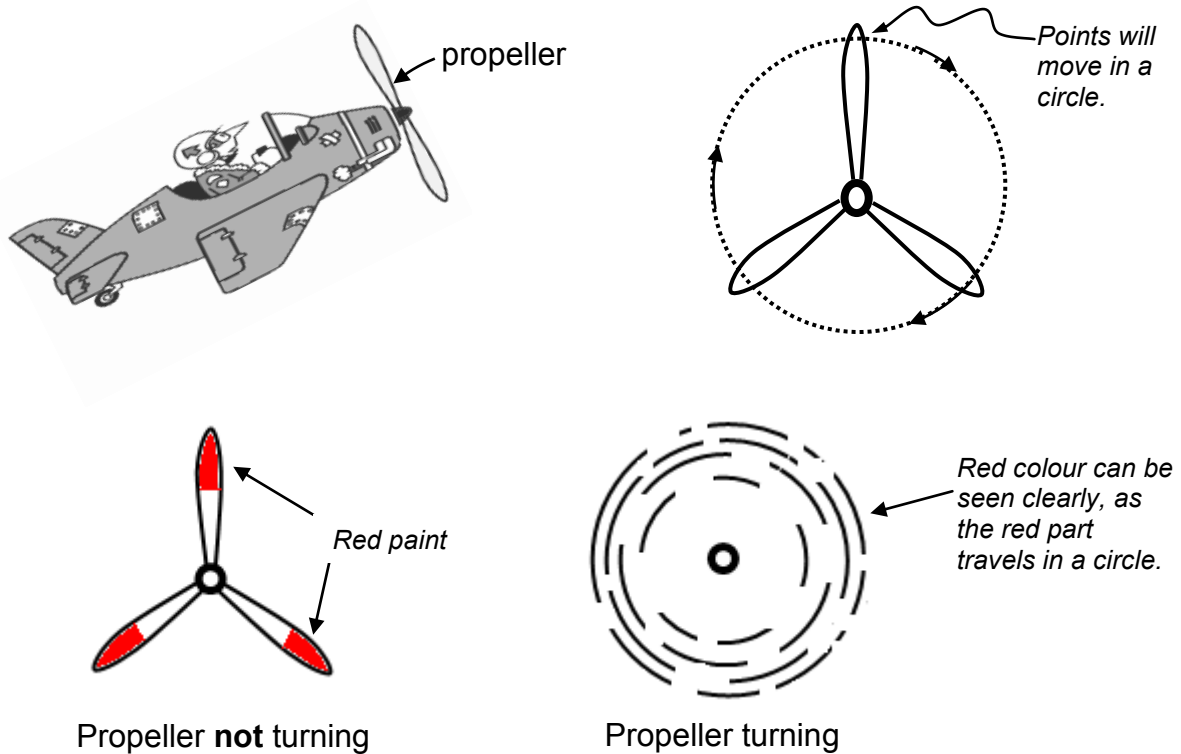
- All points on the circle are the same (equal) distance from the central point called the centre.
- The centre of a circle is the middle point in the circle.
- All points on the circle are in the same plane.
- A plane is a flat surface.

Here is another example of a circle.

Have you seen a propeller of an airplane as the airplane is getting ready to take off?

The ends of the propeller are sometimes painted with yellow or red so that they can be seen clearly.

As the propeller turns, any point on it will turn in a circular path.



Propeller **not** turning

Propeller turning

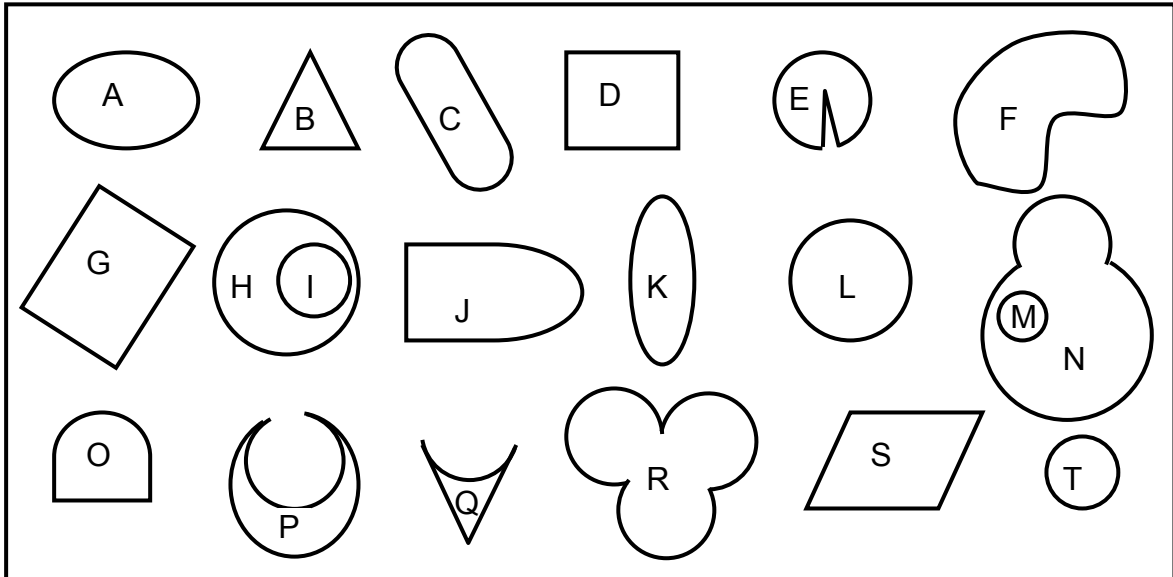
---

**NOW DO PRACTICE EXERCISE 7.**



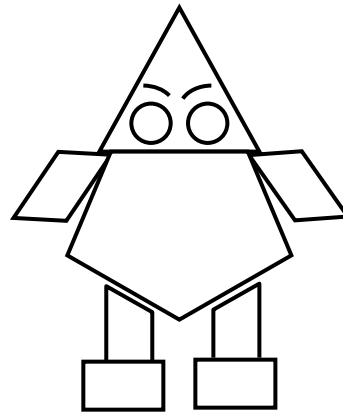
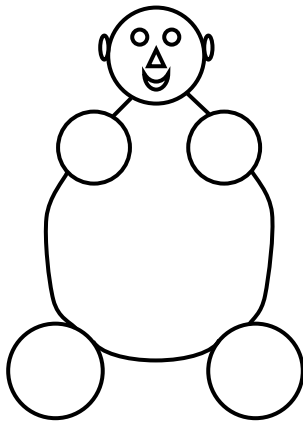
## Practice Exercise 7

1. Which of the shapes shown below are circles? Write the letter of the shape in the answer space below;



**Answer:** These are circles: \_\_\_\_\_

2. Different shapes were used to form the drawings below.



- a) How many circles were used?
- b) Shade the circles?

**CORRECT YOUR WORK. ANSWERS ARE AT THE END OF SUB-STRAND 2.**

## Lesson 8: Parts of a Circle



In the previous lesson, you learnt the meaning of a circle and differentiated it from other shapes.

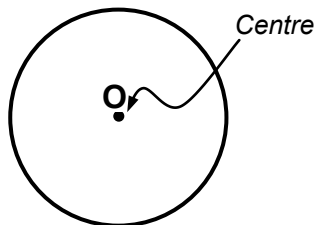


In this lesson, you will:

- describe different parts of a circle
- discuss the relationship between the different parts of the circle.

You learnt that a circle is a closed figure on a plane, all points of which are the same distance away from a fixed point within called the **centre**.

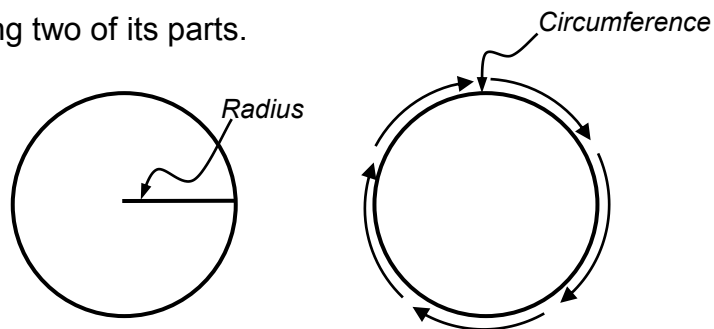
In the figure below, O is the centre of the circle.



A circle is named by its centre. Thus we call the circle, circle O.

Now, you will learn the different parts of a circle.

Here is circle showing two of its parts.



**The radius of a circle is a line segment whose endpoints are a point on the circle and the centre of the circle.**

**It is the distance from the centre to any point on the circle.**

If we draw the radius, it is a straight line.

The plural of radius is **radii** ( you say *Ray-dee-eye*).

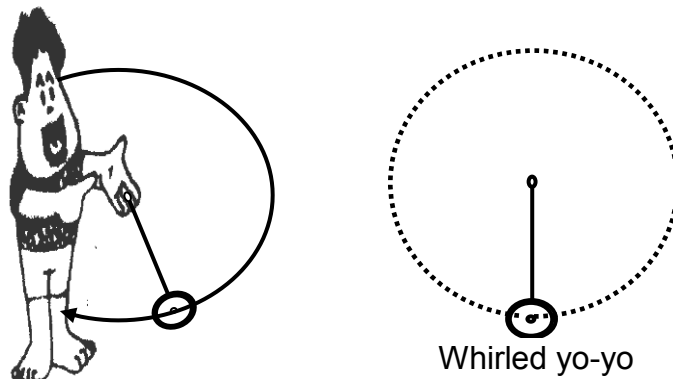
Any circle big or small has an infinite number of radii. The size of the circle does not affect the number of radii it may have.

**The circumference is the distance around a circle.**

If you draw the circumference, it is a curved line.

Here is an example showing the radius and the circumference of a circle in real life.

If Ravo whirled a yo-yo on its stretched string, the path it describes is a circle. The string is the radius of the circle. It keeps the yo-yo at a fixed distance from the hands of Ravo at the centre of the circle.



Ravo's hand is at the centre of a circle.

The string is the radius of the circle.

The yo-yo travels around the circumference of the circle.

Now let us look at the figures below.

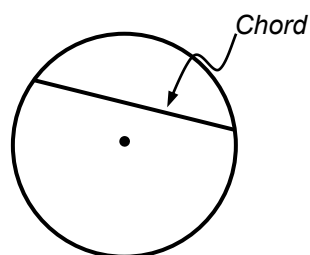


Figure 1

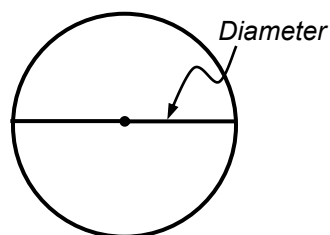
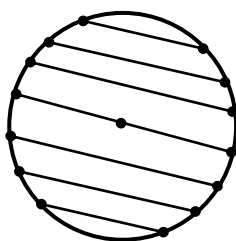


Figure 2

The figures illustrate two more line segments related to circles.

**A chord of a circle is a line segment that joins two points on the circle.  
You say „kord“.**

All these straight lines are chords.



A diameter is a special chord, which passes through the centre .

**The diameter is a line segment connecting two points of the circle passing through the centre.**

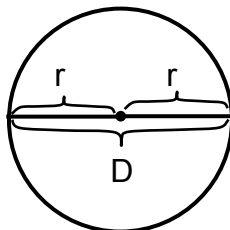
A diameter is the longest straight line segment which can be drawn in a circle.

It is the distance across the middle of a circle through the centre.

The diameter of a circle is twice its radius.

$$1 \text{ DIAMETER} = 2 \times \text{RADII}$$

We say  $D = 2 \times r$



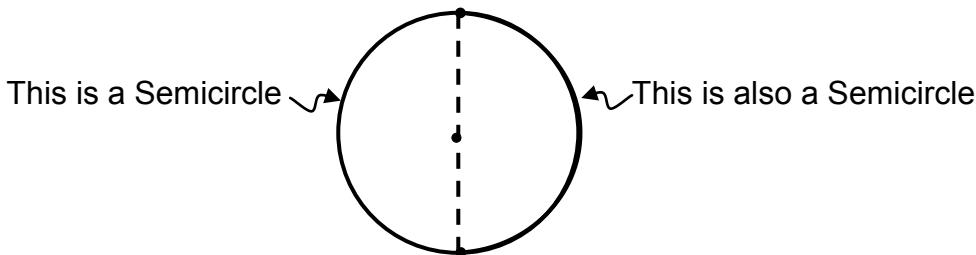
We write **r** for radius and **D** for diameter.

If we draw the diameter, it is a straight line. It divides the circle into two **semicircles**.

*That's a new word. What does a semicircle mean?*



**A semicircle is half of the circumference of a circle.  
(„Semi“ means „Half“)**



Two semicircles make up the whole circle. One semicircle is exactly half of the circumference of the circle.

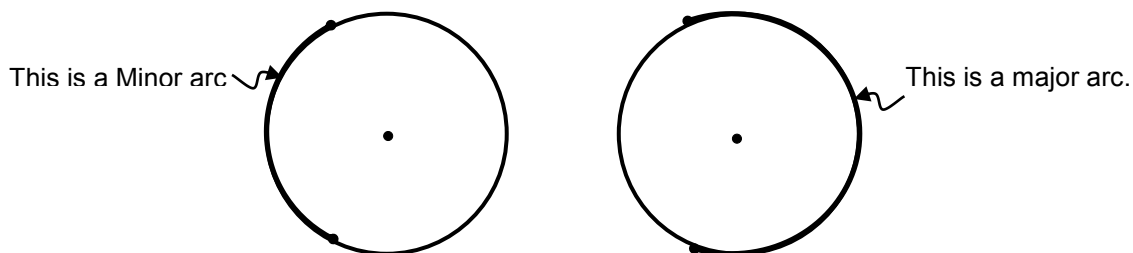
Another part of a circle is the **arc**.

*What is an arc?*



**An arc is any part or portion of the circumference of a circle.  
(You say "ark")**  
**A major arc is an arc greater than a semicircle.**  
**A minor arc is an arc less than a semicircle.**  
**In fact, a semicircle is a special kind of arc.**





Any pair of points on a circle determines two arcs. The two arcs make up the entire circle. A **circle** has a **degree measure** of  $360^\circ$ . A **semicircle** has  $180^\circ$ . A **major arc** has a measure greater than  $180^\circ$  and a **minor arc** has less than  $180^\circ$ .

In the figure below, the centre of the circle is at point O, segments  $\overline{OA}$  and  $\overline{OB}$  are radii. The angle formed by them,  $\angle AOB$  (marked  $\sphericalangle$ ), is called a **central angle**. It's intercepted arc is arc AB. The section bounded by two radii and the included arc of the circle is called a **sector**.



$\angle AOB$  is the central angle

$\widehat{AOB}$  is the sector of the circle

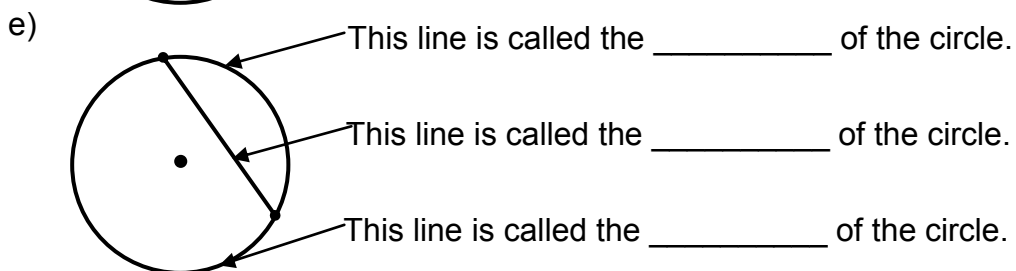
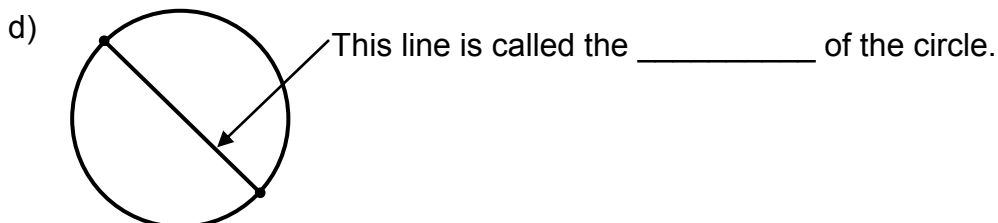
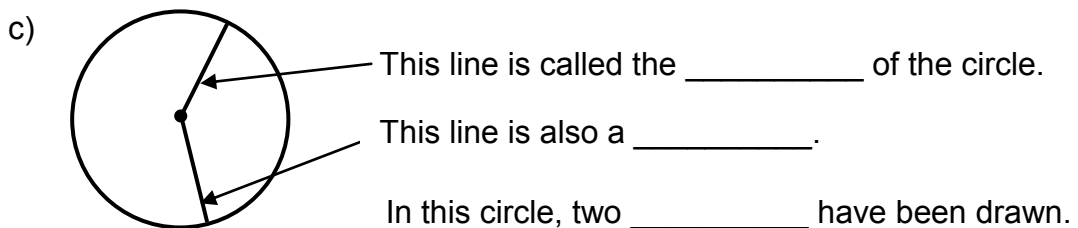
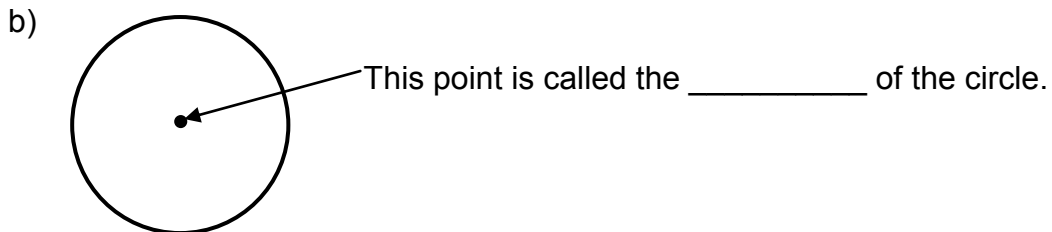
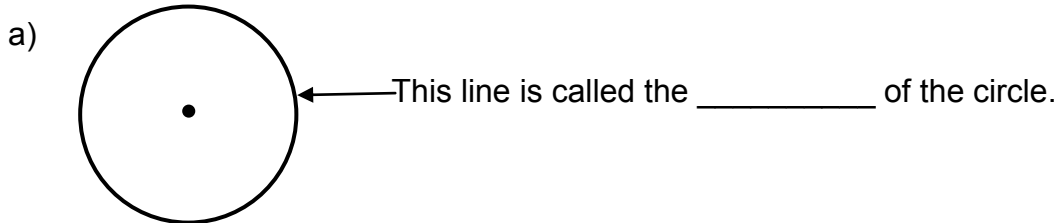
- A central angle is an angle whose vertex is the centre of the circle and whose sides are the radii of the circle.
- „Intercept“ means „cut off“.
- The intercepted arc of an angle is the arc whose endpoints are on each side of the angle and all other points of the arc are in the interior of the angle.
- An arc has the same measure as its central angle.
- The sector is the section or area bounded by two radii and the included arc of a circle.

NOW DO PRACTICE EXERCISE 8



## Practice Exercise 8

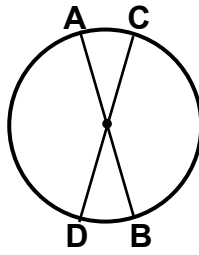
1. Name the parts of the circles below as indicated by the arrows.



2. Complete these sentences by filling in the missing word.

- The diameter of a circle is \_\_\_\_\_ its radius.
- A circle has a degree measure of \_\_\_\_\_.
- A semicircle is half of the \_\_\_\_\_ of the circle. It has \_\_\_\_\_ degrees.
- A semicircle is greater than a \_\_\_\_\_ arc and less than a \_\_\_\_\_ arc.

3. In the figure,  $\overline{AB}$  and  $\overline{CD}$  are diameters of the circle.



Is  $\overline{AB}$  the same length as  $\overline{CD}$ ?

**Answer:** \_\_\_\_\_

---

4. If the radius of a circle is 4 cm, how long is its diameter?

**Answer:** \_\_\_\_\_

---

5. If the diameter of a circle is 14 cm, how long is its radius?

**Answer:** \_\_\_\_\_

---

**CORRECT YOUR WORK. ANSWERS ARE AT THE END OF SUB-STRAND 2.**

## Lesson 9: Naming Parts of a Circle



In the last lesson, you learnt to recognise the different parts of a circle and show the relationships between each other.

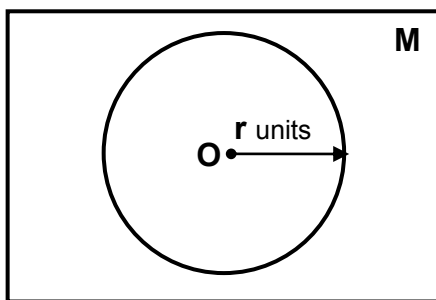


In this lesson, you will:

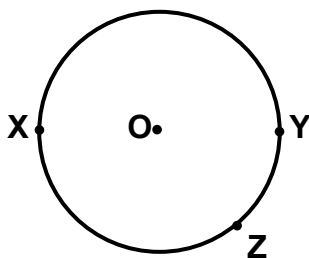
- name and identify the parts of a circle
- draw and illustrate the parts of a circle.

You know how to recognise the different parts of a circle. Now you will learn to give names to these parts, by using letters of the alphabet.

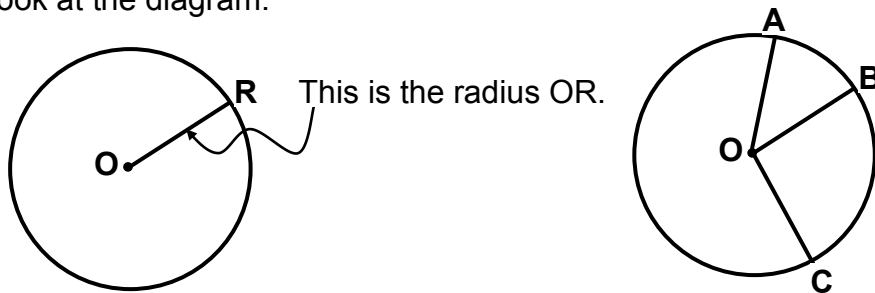
For example. In the diagram below, Point O is in plane M. All the points in plane M whose distances from O is the same ( $r$  units), determine a circle. Point O is the centre of the circle. We usually name the centre of a circle with the letter O. A circle is named by its centre. Therefore we call the circle in the diagram Circle O.



We name points on the circumference of a circle with letters such as X, Y and Z as shown below.



Look at the diagram.

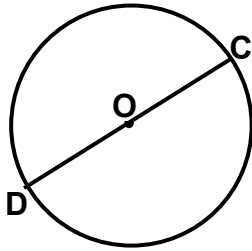


Here are some radii: OA, OB and OC.

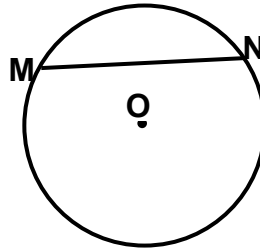
To name the radius, we use the letters that are associated with the two points at each end.

The same is applied to the diameter and chord.

This is the diameter DC.

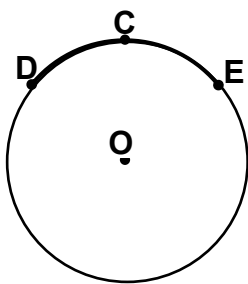


This is the chord MN.

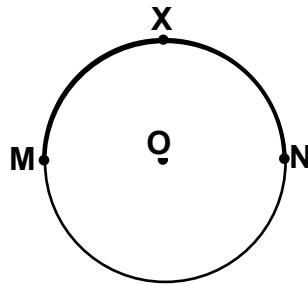


**REMEMBER:**  
 We use one letter to name a point.  
 We use two letters to name a line.

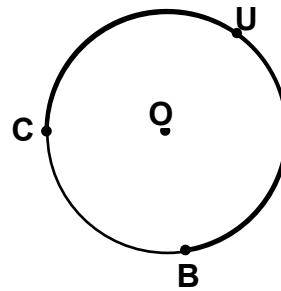
To name an arc or a semicircle which are curved lines we use three letters.



The arc DCE or  $\widehat{DCE}$



The semicircle MXN or  $\widehat{MXN}$



The arc CUB or  $\widehat{CUB}$

**NOTE:**

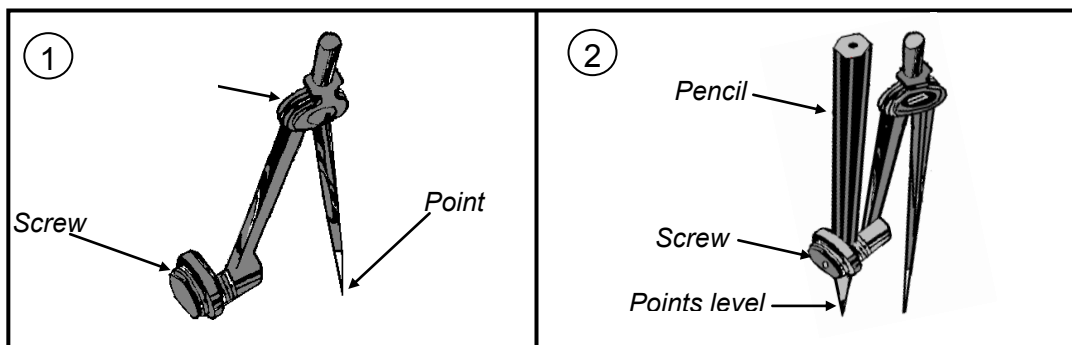
A line EF can also be called FE.

An arc ABC can also be called CBA.

Now that you know something about circles, let us try to draw some.

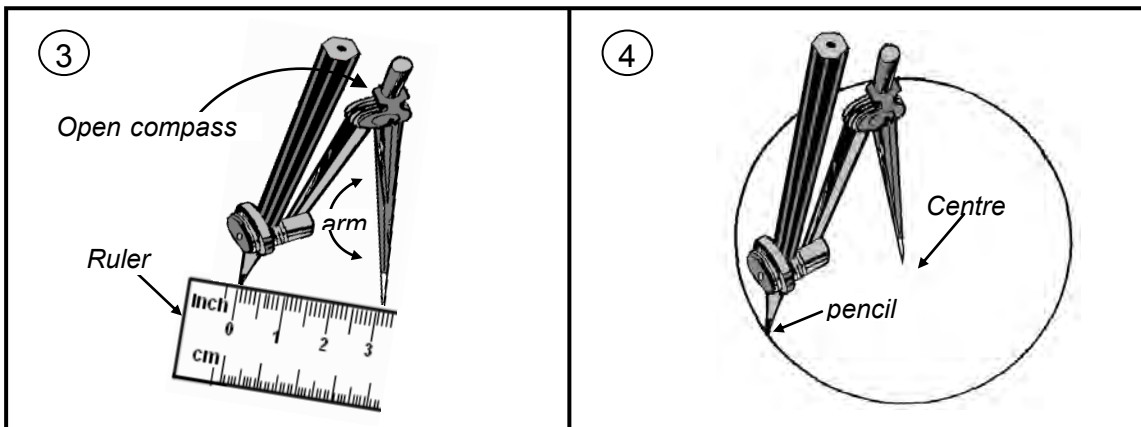
One way of drawing circles is by using the **compass**.

Here is how you use the compass.



This is a compass.

This compass has a pencil screwed in it.



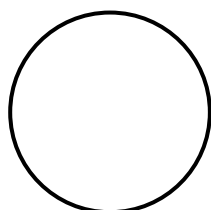
The compass is opened 3 centimetres.

The compass point stays at the centre. The pencil point draws a circle with a radius of 3 cm.

The radius of the circle will be equal to the distance between the point of the compass and the pencil point.

In case you do not have a compass, here are other ways you can draw circles.

1. You can draw a circle by using something which already has a circular shape like the rim of a cup or a plate, a tin of fish or any other circular objects.

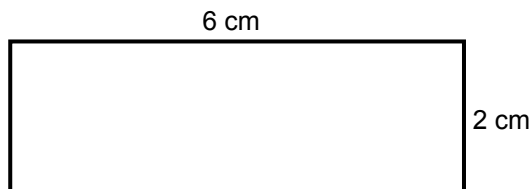


← This circle was drawn using a one kina coin.

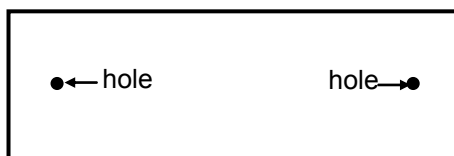
2. You can draw a circle by using this method.

You may need a pencil , pin or drawing pin, ruler or cardboard.

Step 1: Cut or tear a strip of paper or cardboard of any length, For example, 5 cm to 10 cm.



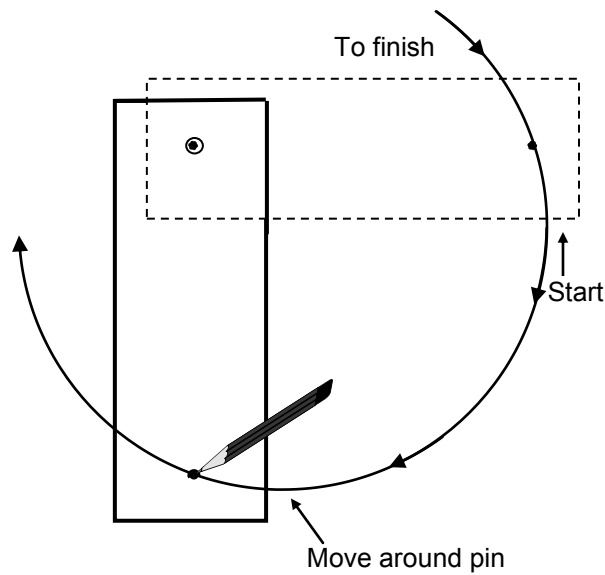
Step 2: Make two holes at the two ends of the strip, about one centimetre from each end.



- Step 3 Put the pin through one hole and hold it on a piece of paper where you want the centre of the circle to be.



- Step 4 Place the pencil point on the other hole. Move the pencil on the paper strip around the pin to draw the circle.



Draw and make your own circles of different sizes by having the two holes closer together or farther apart.

---

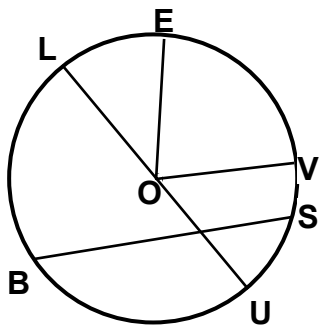
**NOW DO PRACTICE EXERCISE 9**



### Practice Exercise 9

1. Choose then write the correct word from the Word List below to complete each statement in the space provided. You may use the word more than once. The first one is done for you as an example.

**Centre   Radius   Arc   Semicircle   Diameter**



- a) OE is a radius
- b) OV is a \_\_\_\_\_
- c) OU is a \_\_\_\_\_
- d) OL is a \_\_\_\_\_
- e) LU is a \_\_\_\_\_
- f) BS is a \_\_\_\_\_
- g) O is the \_\_\_\_\_
- h) LEU is a \_\_\_\_\_
- i) UVE is an \_\_\_\_\_
- j) UEB is an \_\_\_\_\_

2. Using the circle on the right, name:

- a) two semicircles

**Answer:** \_\_\_\_\_, \_\_\_\_\_

- b) four minor arcs

**Answer:** \_\_\_\_\_, \_\_\_\_\_  
 \_\_\_\_\_, \_\_\_\_\_

- c) four major arcs

**Answer:** \_\_\_\_\_, \_\_\_\_\_, \_\_\_\_\_, \_\_\_\_\_

- d) a diameter

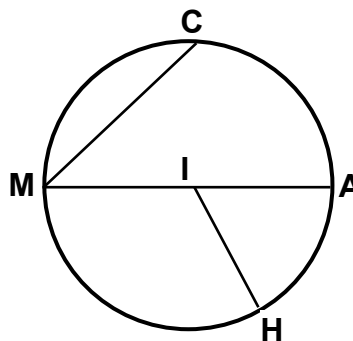
**Answer:** \_\_\_\_\_

- e) a chord

**Answer:** \_\_\_\_\_

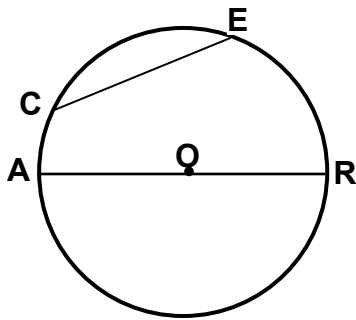
- f) a radius

**Answer:** \_\_\_\_\_





3. Look at the diagram below. Name the different parts using letters.  
The first one is done for you.



- a) The centre is   O    
 b) The diameter is \_\_\_\_\_  
 c) The chord is \_\_\_\_\_  
 d) The two radii are \_\_\_\_\_ and \_\_\_\_\_  
 e) A semicircle is \_\_\_\_\_  
 f) A minor arc is \_\_\_\_\_

4. Draw a circle and label as follows:

- a) centre O  
 b) radius  $\overline{OP}$   
 c) diameter  $\overline{XY}$   
 d) chord  $\overline{AB}$   
 e) arc  $\widehat{AEB}$

**CORRECT YOUR WORK. ANSWERS ARE AT THE END OF SUB-STRAND 2.**

## Lesson 10: Circumference of a Circle



You learnt to illustrate and give names to the different parts of a circle using the letters of the alphabet.



In this lesson, you will:

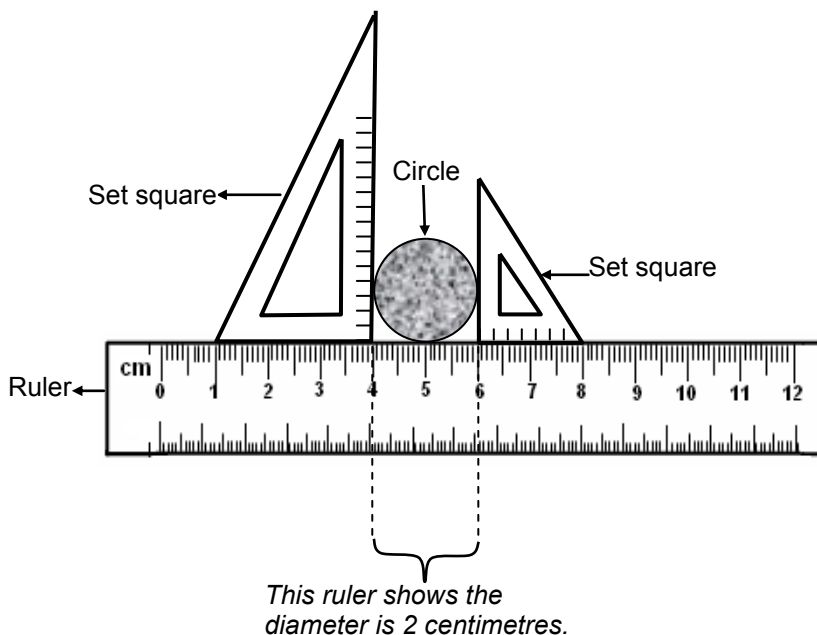
- define the circumference of a circle.
- measure the circumference of a circle.

We identified the different parts of a circle in the previous lesson. We briefly looked at the CIRCUMFERENCE also.

**The circumference is the perimeter (distance around) of a circle.**

How do you find the circumference of a circle?

It is easier to measure the diameter of a circle than its circumference, using either a special gauge or a method like the one shown below with a ruler and set squares.



The diameter is the widest part of the circle.

The distance between the two set squares will be the diameter.

Count the number of millimetres between the two set squares as shown on the ruler.

Knowing the diameter of a circle can help you find the measure of its circumference.

Look at some practical methods on how to find the circumference of a circle. Go on to the next page and investigate these methods.

## Example 1

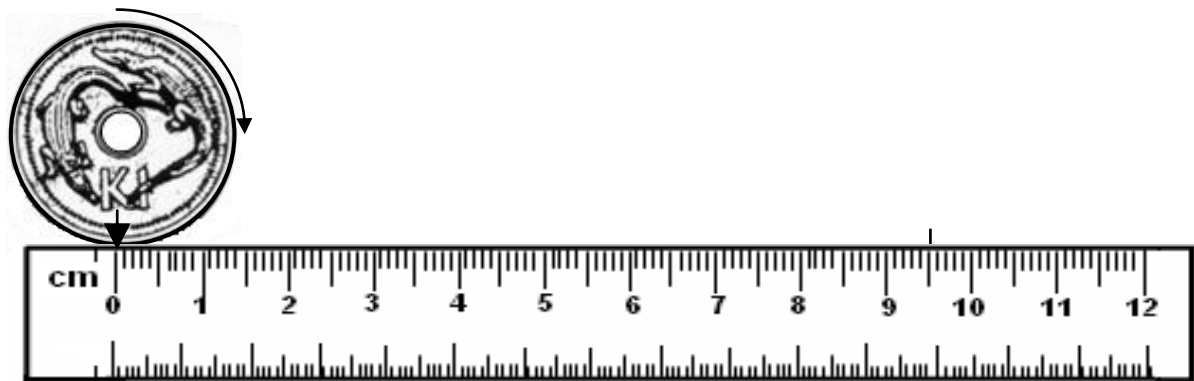
Lets us use some practical methods to measure the circumference of a K1 coin.

**Method 1.**

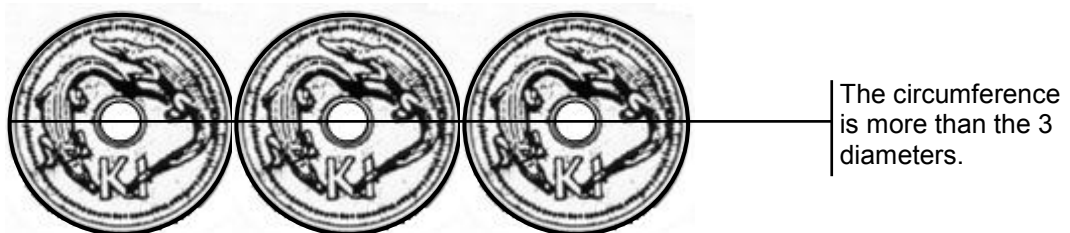
Step 1: Mark a point on the circumference of a K1 coin.



Step 2: Place the coin beside a ruler with the mark pointing to the scale.



Step 3: Roll the coin along the ruler until the mark returns again to the scale. Make sure that the coin does not slip.



Step 4: Measure the circumference.

$$\text{Circumference} = 9.5 \text{ cm}$$

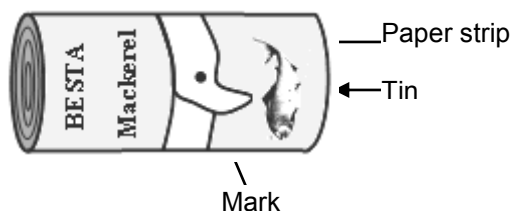
### Example 2

Use a practical method to measure the circumference of a tin can.

#### Method 2

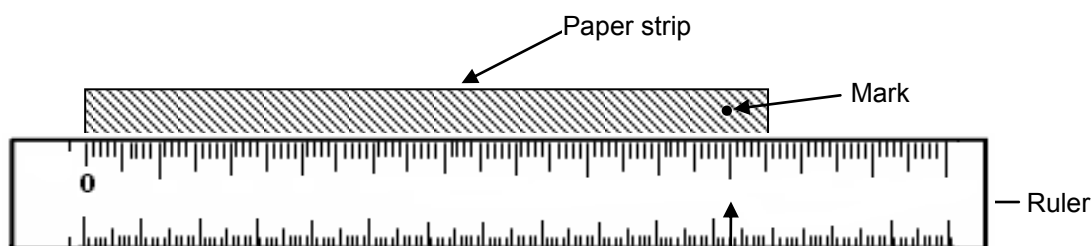
You will need a tin or can which has a good circular shape, a ruler, and a string or a strip of paper.

Step 1: Wrap the string or the strip of paper around the tin or can.



Step 2: Make a mark on the strip where the paper goes around once.

Step 3: Remove the paper strip, and measure the length up to the mark.



**Remember:** Put the zero (0) on your ruler at the place you start to measure from.

The circumference of your tin can is the length of your paper strip up to the mark.

Here is another practical way to measure the circumference.

#### Method 3

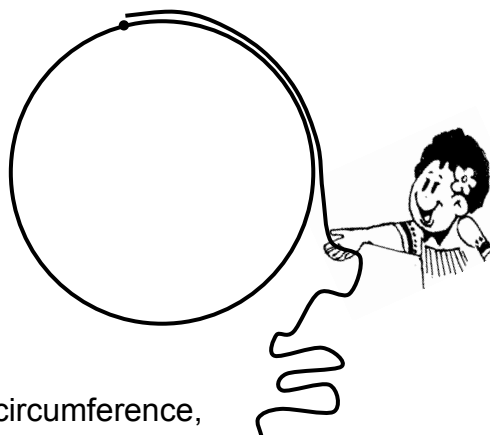
You need any circular objects of any size, a piece of string, and a ruler.

This is what you do.

Step 1: Start at any point on the circle. Put the end of your string there.

Step 2: Carefully place the string along the circumference, until you come back around to the point where you started.

Step 3: Mark the place on your string and cut it.



Step 4: With your ruler, measure the length of the string you used to go around the circumference of the object.



Step 5: The length of the string is the same as the circumference of the object.

---

**NOW DO PRACTICE EXERCISE 10**



## Practice Exercise 10

The following practice exercises will help you find out the special relationship that exists between the circumference of a circle and its diameter.

1. Step 1: Tie a piece of chalk to the end of a long string.
- Step 2: Cut the string so that the chalk is 50 cm away from the other end of the string when stretched.
- Step 3: On a flat surface, or on top of a table, have your friend, brother or sister hold one end while you stretch the string and draw a circle.



- Step 4: Lay the string around the circle you have drawn and then measure the length of the string to find the length of the circumference.

How many diameters would fit around the circumference?

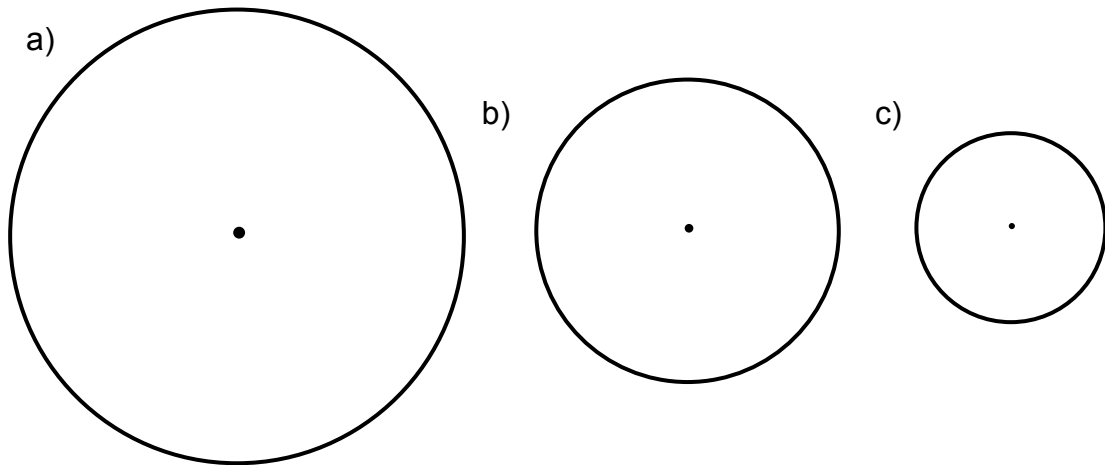
2. The diameter and circumference of 4 circular objects were measured and the results are recorded in the table below.

Complete the third column of the table giving your answers correct to one (1) decimal place.

The first one is done for you.

Diameter (d)	Circumference (c)	Circumference ÷ Diameter (C ÷ d)
2 cm	6.2 cm	3.1 cm
5 cm	15.7 cm	
3.2 cm	10 cm	
8 cm	25 cm	

3. Use a string to trace around each circle to measure its circumference. Also, measure the diameter of each circle and complete the given table. Give the measurement to the nearest millimetre.



Diameter (d)	Circumference (c)	Circumference $\div$ Diameter ( $C \div d$ )
a. 6 cm		
b. 4 cm		
c. 2.5 cm		

**CORRECT YOUR WORK. ANSWERS ARE AT THE END OF SUB-STRAND 2.**

## Lesson 11: The Number Pii ( $\pi$ )

---



In the previous lesson, you learnt to identify and measure the circumference in different practical ways.



In this lesson, you will;

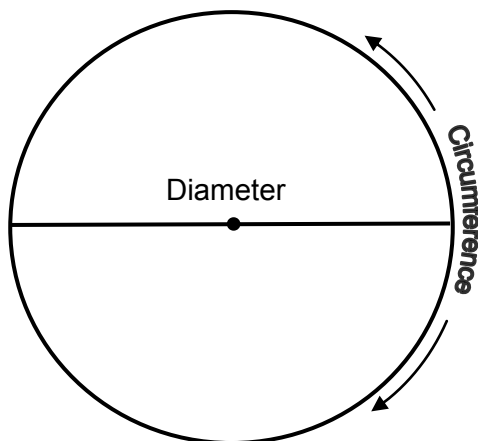
- relate the diameter of a circle to its circumference
  - define the number pii ( $\pi$ )
  - determine the circumference of the circle.
- 

You have measured the diameter and the circumference of a circle in the previous lesson.

Which one is longer? The diameter or the circumference?

Now, you will learn how the diameter and the circumference of a circle are related.

Look at the figure.



The circumference is longer than the diameter.

How much longer is it? Twice as long? Four times as long? Ten times as long?

Now you will find out for yourself the answer to this question.

This is how you find out:

- Step 1: Measure the diameter
- Step 2: Measure the circumference
- Step 3: Divide the circumference by the diameter.

If you do not remember how to measure the diameter and the circumference, Lesson 10 will help you.

Look at the example on the next page.



## Example 1

1. Measure the diameter.

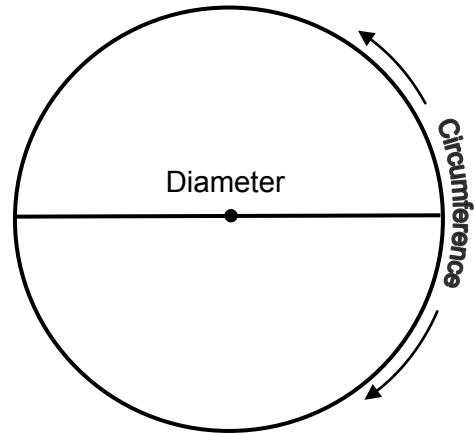
DIAMETER = \_\_\_\_\_ cm

(Answer: 6 cm)

2. Measure the circumference.

CIRCUMFERENCE = \_\_\_\_\_ cm

(Answer: 18.8 cm)



3. Divide :
- $$\frac{\text{CIRCUMFERENCE}}{\text{DIAMETER}}$$
- $$= \frac{18.8}{6}$$
- $$= 3.14$$

3.14 is equal to 3 and a little bit remainder. The remainder is less than half ( $< \frac{1}{2}$ )

The length of the circumference is a bit more than 3 times the length of the diameter. The exact value cannot be written down because it is a decimal that continues forever without repeating.

Because the number is very special it is given the symbol  $\pi$  (the Greek letter pi).

The number  $\pi$  is a strange number that cannot be given an exact decimal or fractional value. We use an approximation of 3.14 (as decimal) or  $\frac{22}{7}$  (as a fraction).

**The number  $\pi$  (pi) is the ratio of the circumference to the diameter of any circle.**

Careful measurement show us that Circumference = Diameter x 3.14.

Instead of writng 3.14, we write the Greek letter for pi as,  $\pi$ .

So, instead of saying Circumference = 3.14 x Diameter

We say that Circumference =  $\pi$  x Diameter (Circumference equals pi times diameter)

In symbols, we write  $C = \pi \times d$

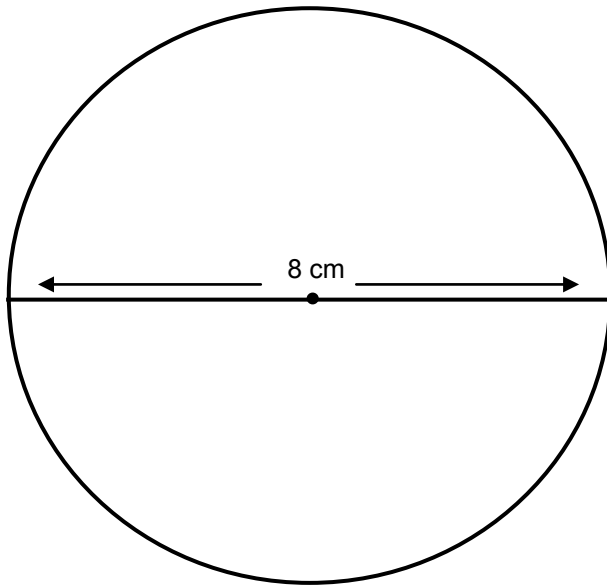
You can also say it like this,  $\pi = \frac{C}{d}$  (Pi equals circumference divided by diameter)

With these in mind, you can now use formulas to work out the length of the circumference.

See examples on the next page.

## Example 1

The circle below has a diameter of 8 cm. What is the length of the circumference?



Using the formula,

$$\begin{aligned} C &= \pi \times d \\ &= 3.14 \times d \quad (\text{because } \pi = 3.14) \\ &= 3.14 \times 8 \text{ cm} \quad (\text{because } d = 8 \text{ cm}) \\ &= 25.12 \text{ cm} \end{aligned}$$

**Answer:** The circumference is approximately equal to **25.12 cm**.

Now use a piece of string and measure the length of the circumference of the circle to check if the answer is correct.

Is the circumference equal to 25.12 cm? You should find that it is approximately equal.



How do we work out the circumference if the radius is the one given and not the diameter?

You learnt in Lesson 8 that the diameter of a circle is two times its radius.

Therefore, we can also say that

$$\text{CIRCUMFERENCE} = \pi \times 2r \quad (\text{because } 1 \text{ diameter} = 2 \text{ radii}) \text{ or}$$

$$C = 2\pi r$$

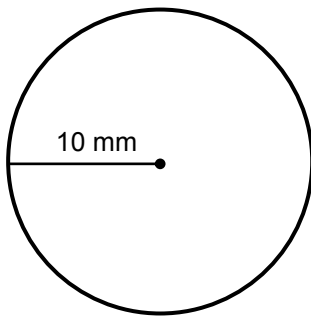
So, to find the circumference of a circle given its radius use the formula

$$C = 2\pi r$$

Now look at example 2 on the next page.

## Example 2

Find the circumference of the circle below .



$$\text{Use } C = 2\pi r$$

$$= 2 \times 3.14 \times 10 \text{ mm}$$

$$= 6.28 \times 10$$

$$= 62.8 \text{ mm}$$

---

**NOW DO PRACTICE EXERCISE 11**

**Practice Exercise 11**

---

A. Answer the following questions.

1. Is the circumference of a circle longer than its diameter?

Answer: \_\_\_\_\_

---

2. How many times will the diameter of a circle divide into the circumference?

Answer: \_\_\_\_\_

---

3. Will the diameter of a circle divide an exact number of times into the circumference? Yes or No.

Answer: \_\_\_\_\_

---

4. The \_\_\_\_\_ is the ratio of the circumference to the diameter of any circle.

Answer: \_\_\_\_\_

---

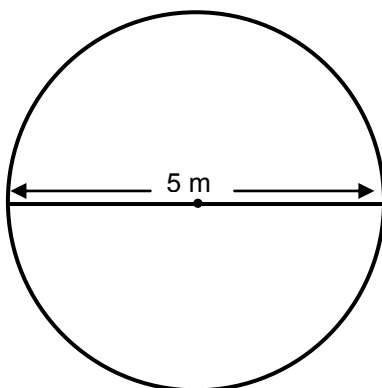
5. The approximated value of  $\pi$  is \_\_\_\_\_.

Answer: \_\_\_\_\_

---

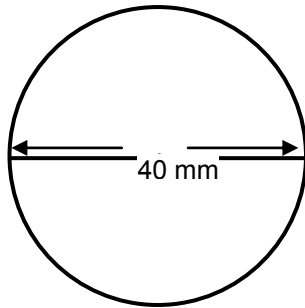
B. Work out the circumference of each circle below. The length of the diameter is shown.

1)



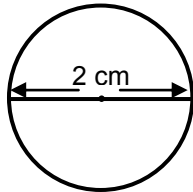
Answer: \_\_\_\_\_

2)



Answer: \_\_\_\_\_

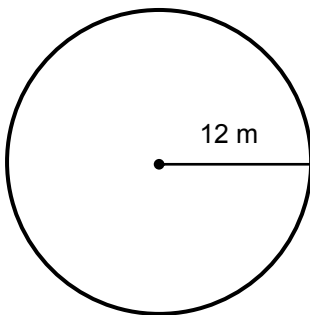
3)



Answer: \_\_\_\_\_

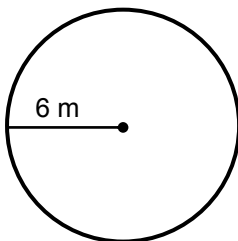
C. How long is the circumference of each of these circles?

1)



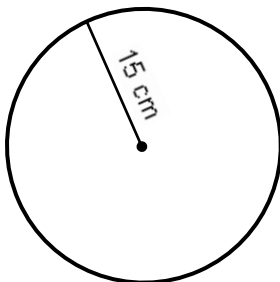
Answer: \_\_\_\_\_

2)



Answer: \_\_\_\_\_

3)



Answer: \_\_\_\_\_

**CORRECT YOUR WORK. ANSWERS ARE AT THE END OF SUB-STRAND 2.**

## Lesson 12: Solving Problems Involving Circumference



In the previous lesson, you learnt the meaning of the number  $\pi$  and to find the circumference of a circle.



In this lesson, you will:

- solve problems involving circumference.

The circumference is harder to measure accurately but if you know the radius or the diameter then you can calculate the circumference and be able to apply the skills to solve problems in real life.

First, we will revise the main points you need to solve problems involving circumference.

### REMEMBER:

**Radius is a line from the centre to any point on the circle.**

**Diameter is a line joining two points on the circle passing through the centre.**

**The diameter is twice as long as the radius.**

**The circumference of a circle is the distance around the circle. It is a special name for the perimeter of a circle.**

**To find the circumference, the diameter is multiplied by a number close to 3 which is represented by the Greek letter  $\pi$  (Pii), pronounced „pè“:**

**The number  $\pi$  is approximately equal to**

- 3.14, as decimal
- or  $\frac{22}{7}$ , as a fraction.

**$\pi$  is the answer we get when we divide the circumference by the diameter of a circle.**

**As a rule or formula, it is written as  $\pi = \frac{C}{d}$ .**

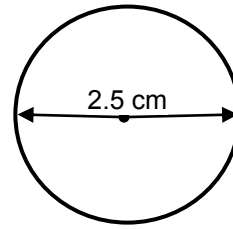
**This formula can be written as  $C = \pi \times d$  and  $C = \pi \times 2r$   
or  $C = 2\pi r$  (because 1diameter = 2 radii).**

In this lesson you will usually be told which approximation to use for  $\pi$ .

### Example 1

Find the circumference of the circle if  $\pi = 3.1$ .

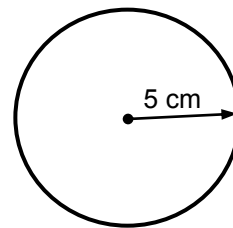
Solution:  $C = \pi \times d$   
 $= 3.1 \times 2.5$  (diameter of the circle)  
 $= \mathbf{7.75 \text{ cm}}$



### Example 2

Find the circumference of the circle if  $\pi = 3.14$ .

Solution:  $C = 2\pi r$   
 $= 2 \times 3.14 \times 5$  (radius of the circle)  
 $= \mathbf{31.4 \text{ cm}}$



Now, let us solve problems involving the circumference in real life .

### Example 1

A car tyre has a diameter of 60 cm.

How far will the wheel travel in one revolution? Use  $\pi = 3.14$ .



Solution:

1 revolution is equal to one full circle or one rotation.

So, the distance that the wheel travels will be equal to its circumference.

Therefore, the Circumference of the wheel =  $\pi d$

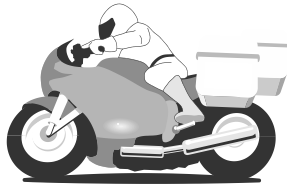
$$C = 3.14 \times 60 \text{ cm}$$

$$= 188.4 \text{ cm}$$

Answer: The wheel travels **188.4 cm** in one revolution.

## Example 2

The front wheel on Asi's bike has a diameter of 70 cm.



- a) What is the circumference of the wheel? Use  $\pi = 3.14$ .  
 b) Asi cycles along the road. How far will he travel each time the front wheel turns 10 times?

Solution. a)  $C = \pi d$   
 $= 3.14 \times 70\text{cm}$   
 $= 219.8 \text{ cm}$

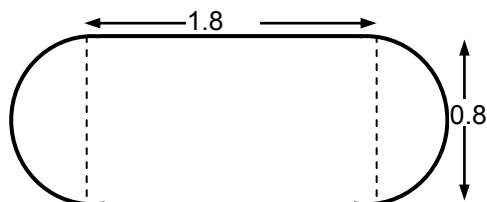
Therefore, the circumference of the front wheel is **219.8 cm**.

b) Asi travels 10 x Circumference of the wheel  
 $= 10 \times 219.8 \text{ cm}$   
 $= 2198 \text{ cm}.$

Therefore, Asi travels **2198 cm** each time the front wheel turns 10 times.

## Example 3

Cars race around a track with the measurements as shown.



Using  $\pi = 3.14$ , find

- a) the length of the track  
 b) the distance of a 20-lap race to the nearest km

Solution: a) To find the length of the track, we add the lengths of the two straight sides and the length of the two semicircles.

So, Length of the track = 2 x straight sides + 2 x lengths of semicircle

$$\begin{aligned}
 &= 2 \times 1.8 \text{ km} + 2 \times \frac{1}{2} \pi \times 0.8 \\
 &= 3.6 + 3.14 \times 0.8 \\
 &= 3.6 + 2.512 \\
 &= 6.112 \text{ km}
 \end{aligned}$$

Therefore, the length of the track is **6.112 km**.



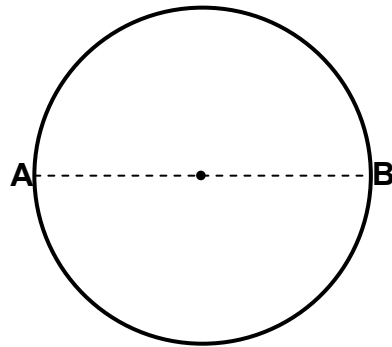
- b) Distance of 20-lap race = 20 times the length of the track  
 =  $20 \times 6.112$   
 = 122.24  
 = 122 km (nearest km)

**Therefore, the distance of a 20-lap race is 122 km.**

#### Example 4

The distance around the circular piece of land is 455.3 metres as shown.

- a) How far would a person walk if he followed a straight path passing through the centre of the land?
- b) How much farther is it to walk around from point **A** to point **B**? Write your answer to the nearest metre.



Solution:

- a) We know that the straight path passing through the centre of the land is the diameter.

So, The distance a person walks following a straight path can be equated to the diameter of the circular land whose diameter is 455.3 metres.

We write; Distance = diameter = circumference  $\div \pi$

$$= 455.3 \div 3.14$$

$$= 145 \text{ m}$$

**Answer: The person would walk 145 m.**

- b) To find how much farther is it to walk around from Point A to Point B, subtract 145 m from 455.3 m.

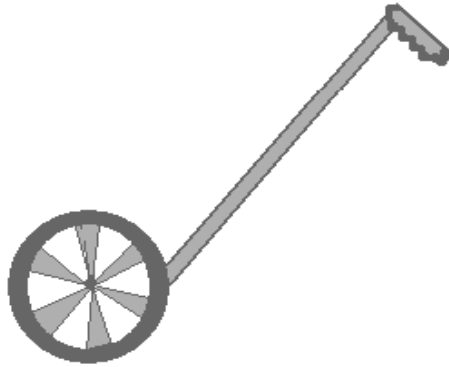
So, Difference =  $455.3 \text{ m} - 145 \text{ m}$

$$= 310.3$$

$$= 310 \text{ to the nearest m.}$$

**Answer: It is 310 m farther.**

4. A trundle wheel below has a circumference of 1 metre.



What must be its diameter, to the nearest millimetres? Use  $\pi = \frac{22}{7}$

Solution:

First, change the circumference of 1 metre to millimetre.

We have 1 m = 1000 mm

To find the diameter, divide the circumference by the value of  $\pi$ .

$$\begin{aligned}\text{Diameter} &= \text{circumference} \div \pi \\ &= 1000 \div \frac{22}{7} \\ &= 318.18 \\ &= 318 \text{ mm (to the nearest mm)}\end{aligned}$$

**Therefore, the diameter must be 318 mm .**

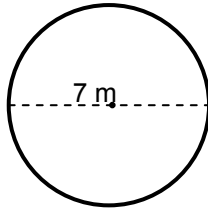
---

**NOW DO PRACTICE EXERCISE 12**

**Practice Exercise 12**

1. Find the circumference of each circle below. Use  $\pi = 3.14$ . Express your answer to the nearest hundredths. The first one is done for you. **Note:** Diagram are not drawn to scale.

a)



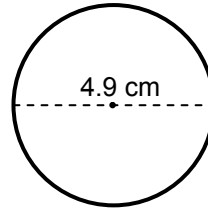
Working out:

$$C = \pi d$$

$$C = 3.14 \times 7\text{m}$$

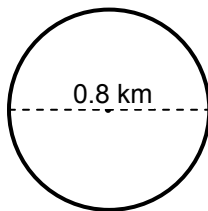
Answer: = **21.98 m**

b)



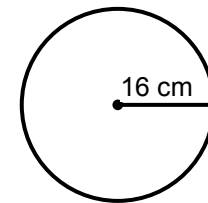
Answer: \_\_\_\_\_

c)

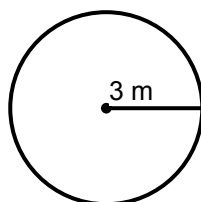


Answer: \_\_\_\_\_

d)



e)



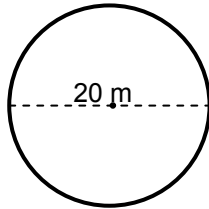
Answer: \_\_\_\_\_

2. Find the circumference of each circle below. Use  $\pi = \frac{22}{7}$

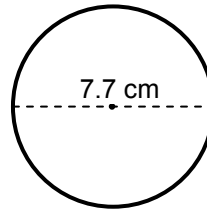
Express your answer to the nearest hundredths. The first one is done for you.

**Note:** Diagrams are not drawn to scale.

a)



b)



Working out:

$$C = \pi d$$

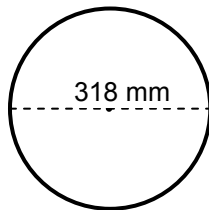
$$C = \frac{22}{7} \times 20\text{m}$$

Answer: **62.85 m**

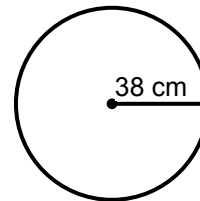
Answer: \_\_\_\_\_

Answer: \_\_\_\_\_

c)



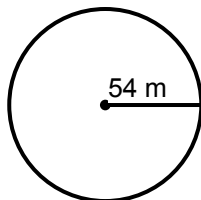
d)



Answer: \_\_\_\_\_

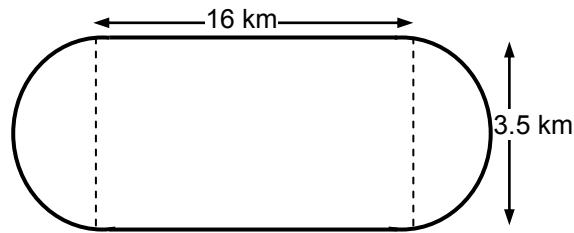
Answer: \_\_\_\_\_

e)



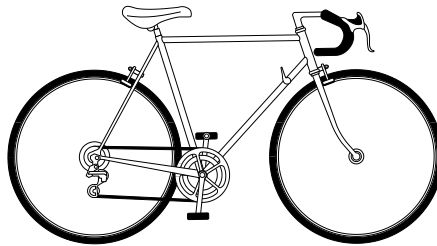
Answer: \_\_\_\_\_

3. Find the distance around the race track with the measurements as shown.  
Use  $\pi = \frac{22}{7}$ .



Answer: \_\_\_\_\_

4. The wheels of the bicycle shown here have diameters of 50 cm.



- a) How far will the bicycle go after one revolution?

Answer: \_\_\_\_\_

- b) How many revolutions will each wheel make to cover a distance of 1 km?

Answer: \_\_\_\_\_

**CORRECT YOUR WORK. ANSWERS ARE AT THE END OF SUB-STRAND 2**

## SUB-STRAND 2: SUMMARY



*This summarises some of the important ideas and terms to remember.*

- A **circle** is a closed figure on a plane (flat surface) all points of which are the same distance away from a fixed point within, called the centre.
- The **Radius** is a line from the centre to any point on the circle.
- The **Diameter** is a line joining two points on the circle passing through the centre.
- The diameter is twice as long as the radius.
- A chord of a circle is a line segment that joins two points on the circle.
- An **arc** has the same measure as its central angle.
- A **major arc** is an arc greater than a semicircle.
- A **minor arc** is an arc less than a semicircle.
- A **semicircle** is half of the circumference of a circle.
- A **central angle** is an angle whose vertex is the centre of the circle and whose sides are the radii of the circle.
- The **intercepted arc** of an angle is the arc whose endpoints are on each side of the angle and all other points of the arc are in the interior of the angle.
- The **sector** is the section or area bounded by two radii and the included arc of a circle.
- The **circumference** of a circle is the distance around the circle. It is a special name for the perimeter of a circle.
- The number  $\pi$  is approximately equal to
  - 3.1 which gives an approximate answer
  - 3.14 which gives a more accurate answer
  - 3.142 which gives an even more accurate answer
  - or  $\frac{22}{7}$ , as a fraction.
- To find the circumference, the diameter is multiplied by a number close to 3 which is represented by the Greek letter  $\pi$  (Pii), pronounced "pie".

In symbols,  $C = \pi \times d$  and  $C = \pi \times 2r$

or  $C = 2\pi r$  (because 1 diameter = 2 radii)

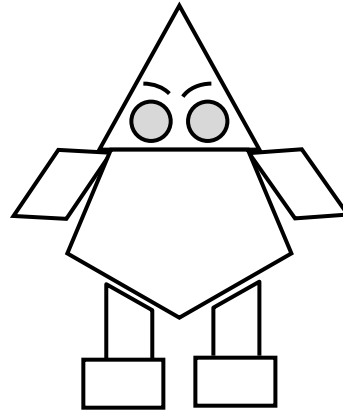
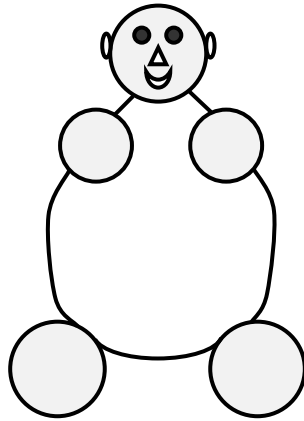
**REVISE LESSONS 7-12 THEN DO SUB-STRAND TEST 2 IN ASSIGNMENT 2.**

**ANSWERS TO PRACTICE EXERCISES 7- 12**

---

**Practice exercise 7**

1. H, I, L, M, T
2. a) 9 circles  
b)

**Practice exercise 8**

1. a) circumference  
b) centre  
c) radius, radius, radii  
d) diameter  
e) arc, chord , arc
  2. a) twice or two times  
b)  $360^\circ$   
c) Circumference;  $180^\circ$   
d) minor arc; major arc
  3. Yes
  4. 8 cm
  5. 7 cm
- 

**Practice Exercise 9**

1. b) radius                      f) chord                      j) arc  
c) radius                      g) centre  
d) radius                      h) semicircle  
e) diameter                    i) arc





3.

Diameter (d)	Circumference (c)	Circumference ÷ Diameter (C ÷ d)
a) 6 cm	18.8	3.1
b) 4 cm	12.5	3.1
c) 2.5 cm	7.8	3.1

**Practice Exercise 11**

A. 1. Yes

2. 3 times

3. No

4. Number  $\pi$ 

5. 3.14 or

B. 1. 15.7 m

2. 125.6 mm

3. 6.28 cm

C. 1. 75.36 m

2. 37.68 m

3. 94.2 cm

**Practice Exercise 12**

1. b) 15.39 cm c) 2.51 km d) 50.24 cm e) 9.42 m

2. b) 24.20 m c) 999.43 mm d) 119.43 cm e) 169.71 m

3. 54 km

4. a) 157 cm b) 63.7 revolution

**END OF SUB-STRAND 2**

## **SUB-STRAND 3**

### **SIMILARITY AND SCALE DRAWING**

**Lesson 13; Similarity**

**Lesson 14: Corresponding Angles and Sides  
(Part 1)**

**Lesson 15: Corresponding Angles and Sides  
(Part 2)**

**Lesson 16: Drawing Similar Triangles**

**Lesson 17: Drawing More Similar Shapes**

**Lesson 18: Scale Drawing**

**SUB-STRAND 3: SIMILARITY AND SCALE DRAWING**

---

**Introduction**

Welcome to Sub-strand 3 of your Grade 8 Mathematics Strand 2.

The world is filled with similarity everywhere you look. There are two-dimensional and three-dimensional shapes of every type.

The places we live in are built from plans and scale drawings. Architects incorporate artistically pleasing patterns, symmetry, and proportion as they design and plan buildings.

**Example**

Note the symmetry and patterns, proportion and artistic elements as you look at the picture.



In this sub-strand, you will learn to identify congruent and similar figures and shapes stating the relevant conditions. You will be able to recognize similar shapes in different positions and draw them. You will also read and make scale drawings and calculate the size of real objects from the scale drawings.

## Lesson 13: Similarity



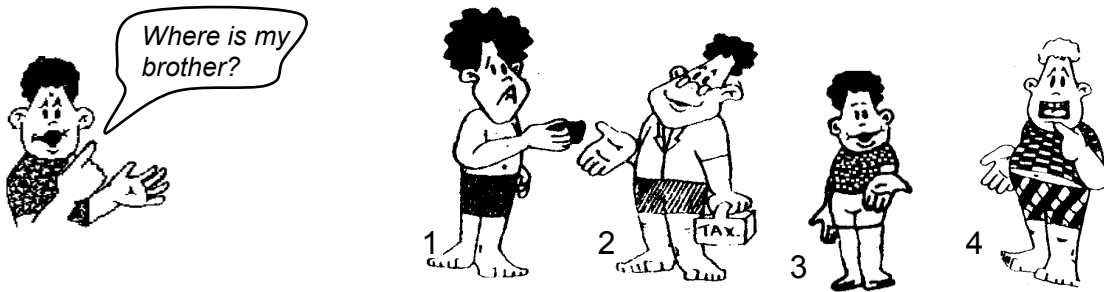
In this lesson, you will:

- define the term „similar“ for shapes
- determine similar shapes and the conditions for similarity.

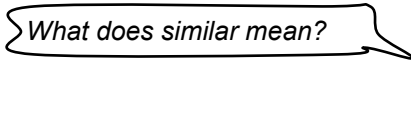
There are many objects and things in nature where we can see similarity.

Look at the example below.

Kila is looking for his brother Kalu. Can you find Kalu in this group?



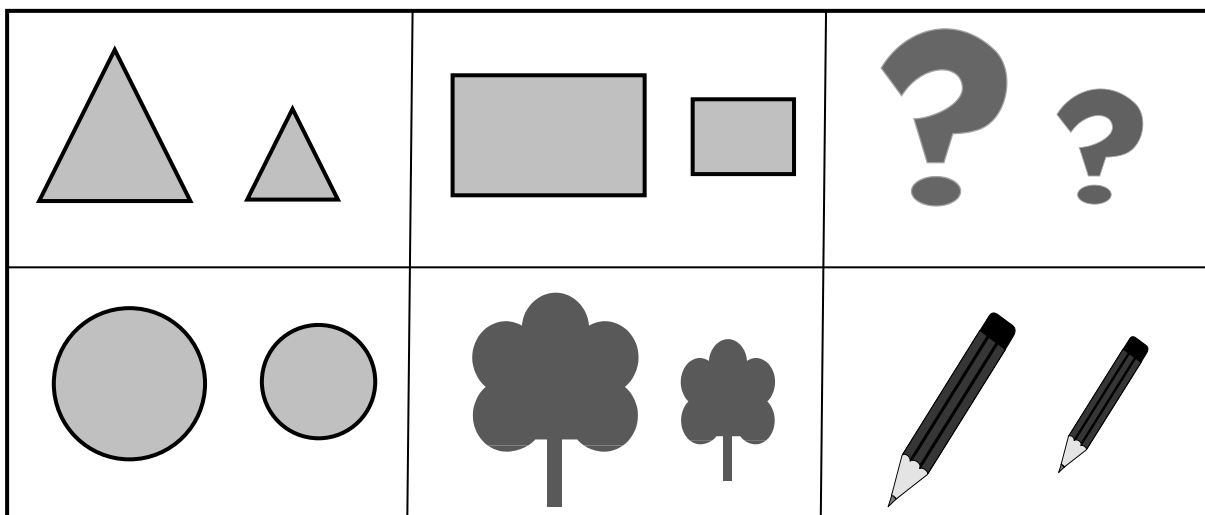
Did you spot Kalu? He is third in the group. Kalu is similar to his brother, Kila.



Similar means „almost equal“ or „nearly the same“.

In Mathematics, the word similar does not mean „almost equal“ or „nearly the same“ but actually means **the same shape**.

Look at the pairs of figures below.



What do you notice?

Each pair of figures above has the **same shape**.

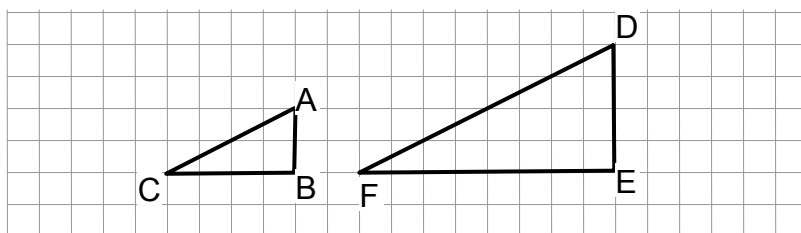
One of each pair is bigger than the other. They have **different sizes**.

We say the figures are **similar**.

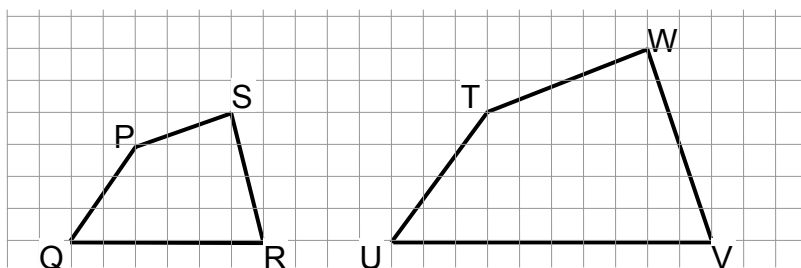
- **Similar means having the same shape, but different size.**
- **Two figures are similar when one figure can be enlarged and superimposed (put, lay or stack one on top of the other) so that they coincide (on the same position) exactly.**
- **Similar figures are figures that have the same shape, but different sizes.**

We use similar figures when enlarging photographs, when using overhead projectors, when making models and in scale drawings.

Now look at the diagrams.



These triangles have the same shape but not the same size.  $\triangle DEF$  has each of its sides twice as long as the sides of  $\triangle ABC$ . We say  $\triangle DEF$  is similar to  $\triangle ABC$ .



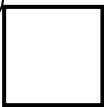

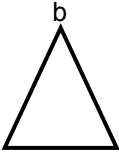
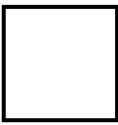


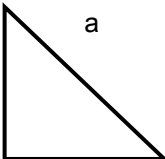
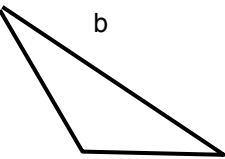
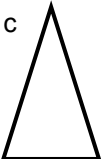
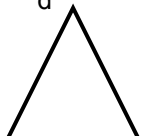
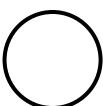
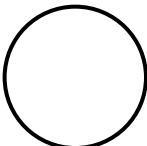

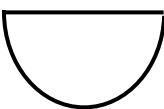
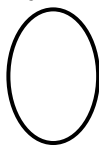






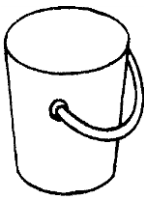



The quadrilateral PQRS is similar to quadrilateral TUVW.

**NOW DO PRACTICE EXERCISE 13**



**Practice Exercise 13**

Look at the shape in Column A. Choose the shape in Column B which is similar to the shape in Column A. Write the letter of the similar shape from Column B in the box provided on the right. The first one is done for you.

COLUMN A	COLUMN B				
① 	a 	b 	c 	d 	<input type="text" value="c"/>
② 	a 	b 	c 	d 	<input type="text"/>
③ 	a 	b 	c 	d 	<input type="text"/>
④ 	a 	b 	c 	d 	<input type="text"/>
⑤ 	a 	b 	c 	d 	<input type="text"/>

**CORRECT YOUR WORK. ANSWERS ARE AT THE END OF SUB-STRAND 2**

## Lesson 14: Corresponding Angles and Sides (Part 1)



In the previous lesson, you defined similarity and identified similar shapes.



In this lesson, you will:

- define „corresponding“
- determine the corresponding angles and sides of similar triangles and polygons

When you have completed this lesson, you will be able to find the corresponding angles and sides of similar shapes

What does „corresponding“ mean?

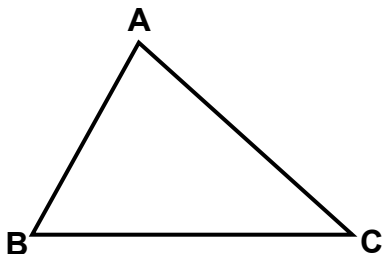


Look again at Grade 7 Strand 2 Sub-strand 4 Lesson 19, page 128.

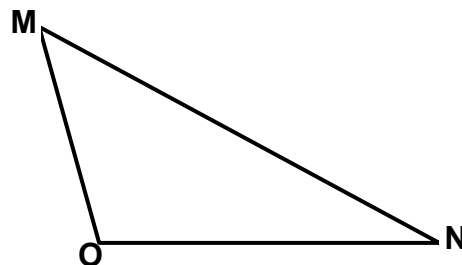
**„Corresponding“ means „matching“.**

First, we will look at the corresponding angles of similar triangles.

We give triangles names by listing the names of the three vertices.



The name of this triangle is  $\triangle ABC$ .



The name of this triangle is  $\triangle MNO$ .

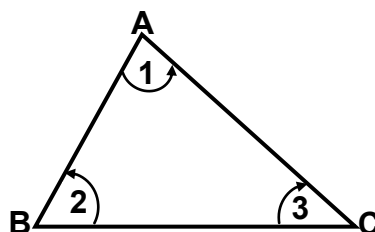
We use the symbol  $\triangle$  to mean „triangle“. We use the symbol  $\angle$  to mean „angle“.

We have listed the three vertices of each triangle to name the triangle.

We can show the angles of a triangle in two ways:

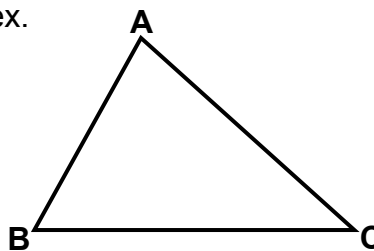
- 1) By writing the numerals inside the triangles shown by an arrow. ↶

- $\angle 1$  is at vertex A
- $\angle 2$  is at vertex B
- $\angle 3$  is at vertex C



2. By writing the letters at each vertex.

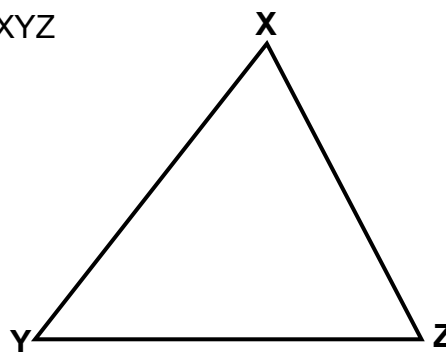
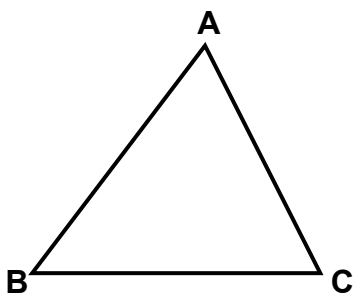
- ∠A is at vertex A
- ∠B is at vertex B
- ∠C is at vertex C



Now you can learn about the corresponding angles in similar triangles.

Example

Here are two similar triangles:  $\triangle ABC$  and  $\triangle XYZ$

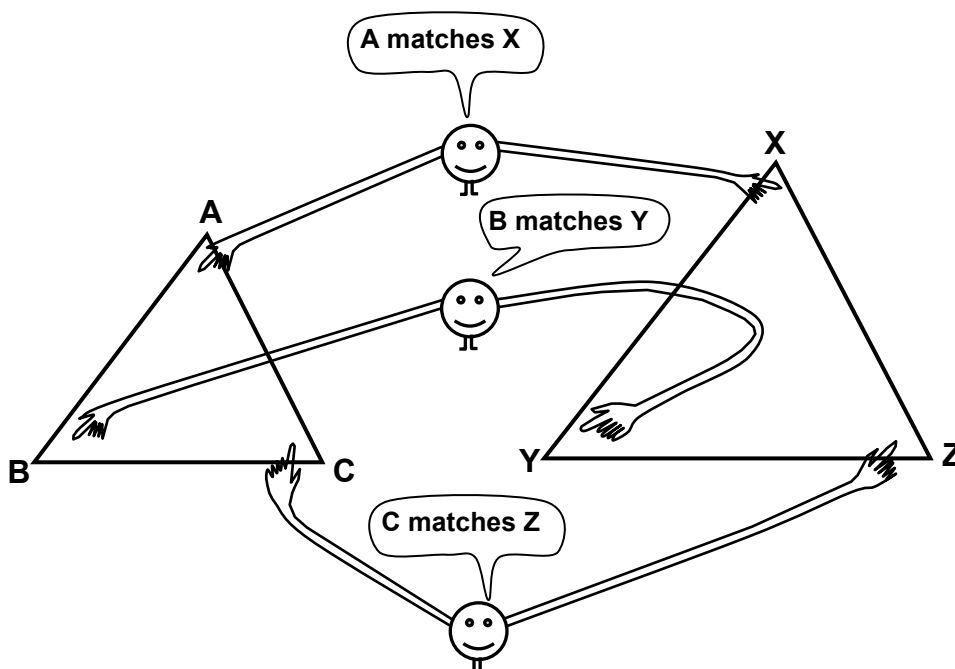


The two triangles are similar because they have the **same shape** but **different sizes**.

Each angle in one triangle corresponds with, or matches an angle in the other triangle.

- We write:
- ∠A corresponds with ∠X
  - ∠B corresponds with ∠Y
  - ∠C corresponds with ∠Z

Here are the two triangles again, with their corresponding angles shown.





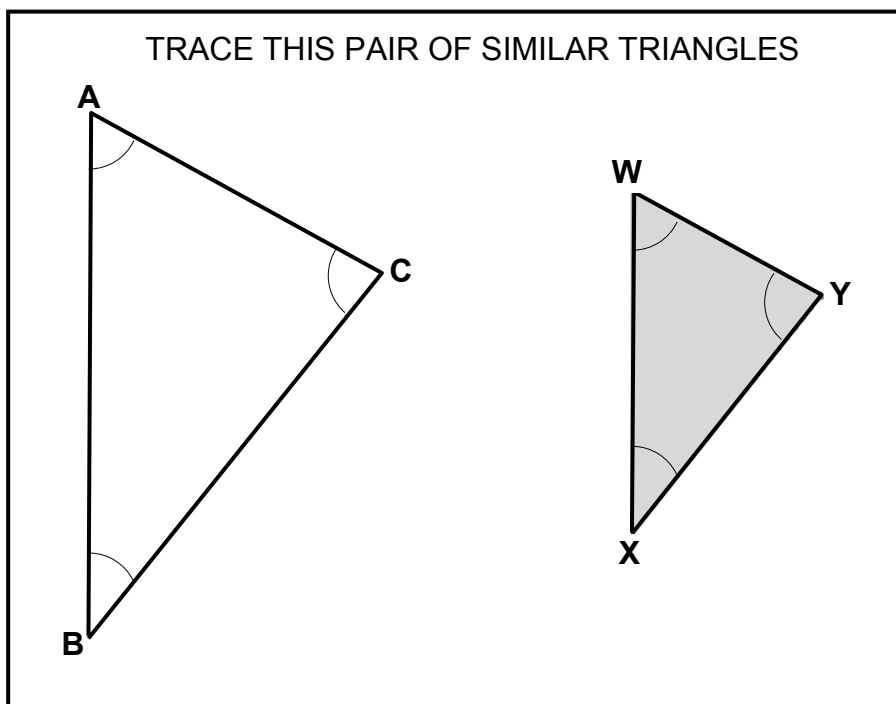


Now do the following activity to find out more about corresponding angles of similar triangles.

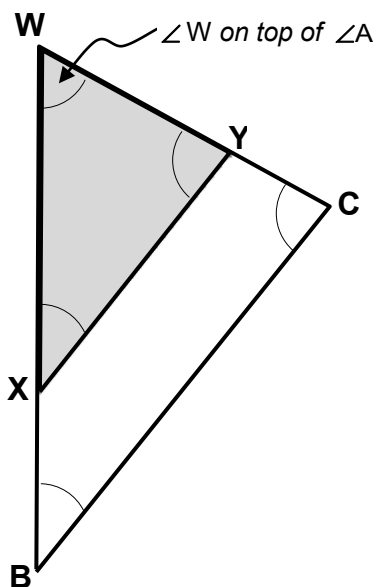
You will need a piece of paper and a pair of scissors.

Here is what you should do.

1. Trace the pair of similar triangles below onto your piece of paper. Mark the angles A, B, C and W, X, Y on your two triangles. Cut out your two triangles.

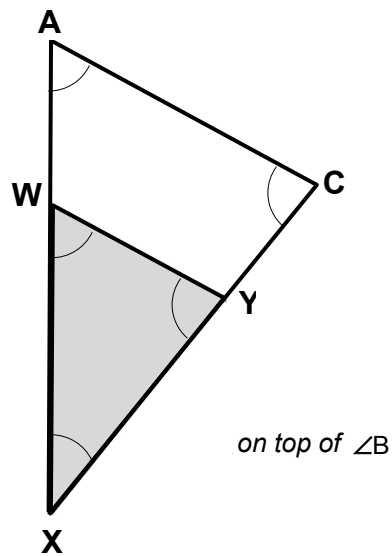


2. Place Angle W on top of its corresponding Angle A so that it covers it. You should find that  $\angle W$  is exactly the same as  $\angle A$ . See diagram below.

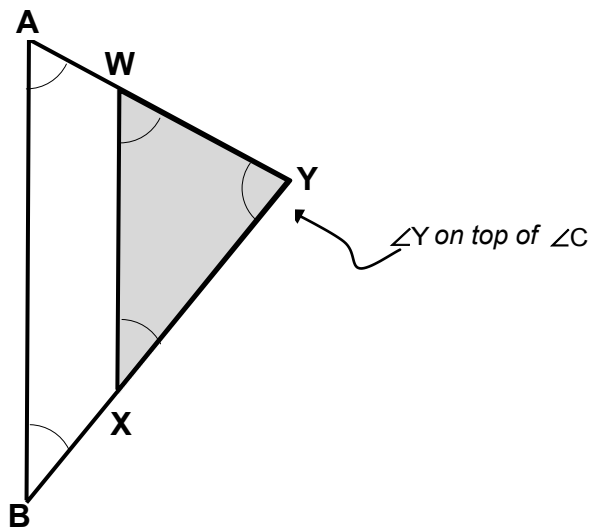


$\angle A$  and  $\angle W$  are equal

3. Next, place Angle X on top of its corresponding Angle B. You should find that  $\angle B$  is exactly the same as  $\angle X$ . See diagram below.



4. Lastly, place Angle Y on top of its corresponding Angle C. See diagram below. Is  $\angle Y$  the same as  $\angle C$ ?



In the activity that you have done, you have found out that:

**Corresponding angles of similar triangles are equal.**

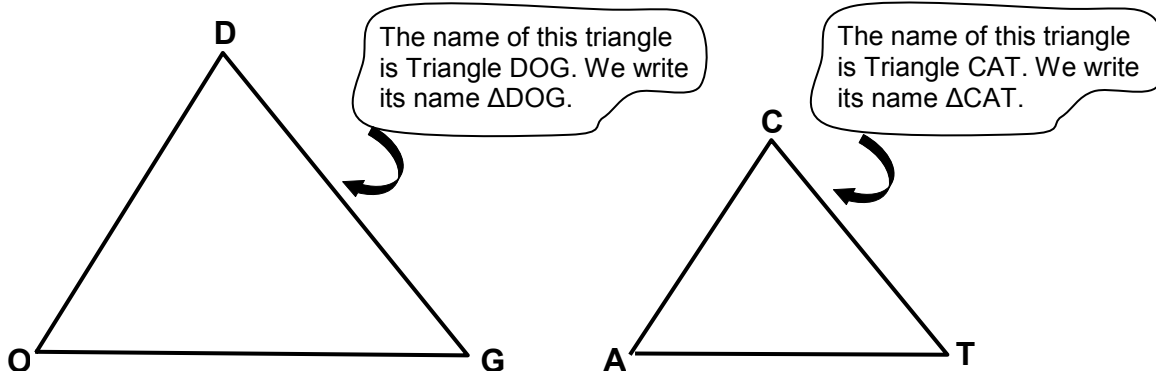
It is also true to say that:

**Two triangles are similar triangles if their corresponding angles are equal.**

Example

Are the two triangles below similar?

Check the angles with your protractor to find out if there are three (3) pairs of equal corresponding angles.



Size of angles in  $\Delta DOG$  are:

$$\begin{aligned} \angle D &= 80^\circ \\ \angle O &= 55^\circ \\ \angle G &= 45^\circ \end{aligned}$$

Size of angles in  $\Delta CAT$  are:

$$\begin{aligned} \angle C &= 80^\circ \\ \angle A &= 55^\circ \\ \angle T &= 45^\circ \end{aligned}$$

Are there 3 pairs of equal corresponding angles?

Yes, because

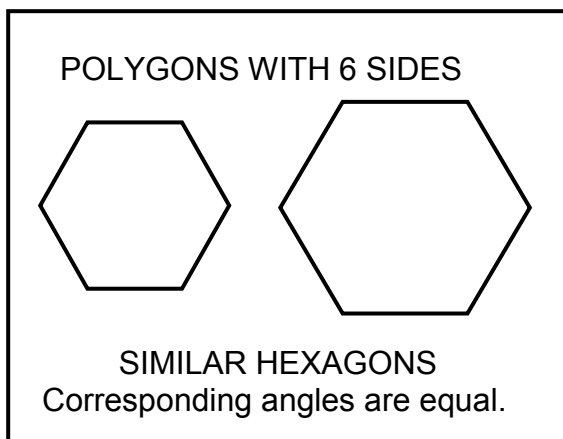
$$\begin{aligned} \angle D &= \angle C && \text{(both are } 80^\circ) \\ \angle O &= \angle A && \text{(both are } 55^\circ) \\ \angle G &= \angle T && \text{(both are } 45^\circ) \end{aligned}$$

So, we can say that  $\Delta DOG$  is similar to  $\Delta CAT$ .



In the same way, you can measure corresponding angles in other similar polygons. You will find that the corresponding angles are always equal.

Example



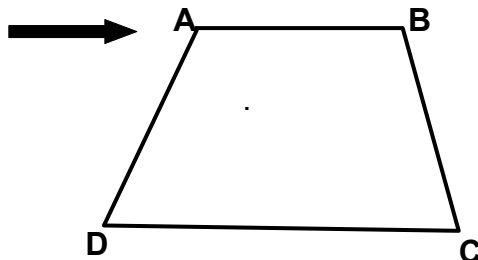
**In similar polygons, (that is shapes having 3 or more sides, the corresponding angles are equal.**



Now, you will learn how to recognise corresponding sides of similar polygons and triangles.

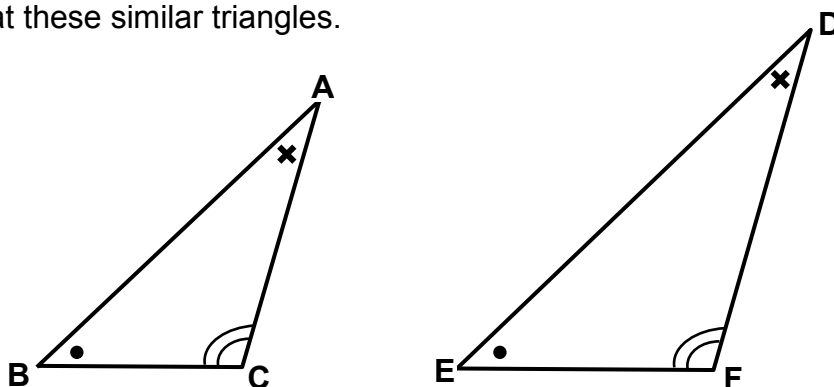
First, you will revise naming the sides of polygons and triangles.

Look at this quadrilateral.



The four (4) sides:  $\overline{AB}$ ,  $\overline{BC}$ ,  $\overline{CD}$  and  $\overline{AD}$ . The points where the sides meet are called vertices A, B, C and D. Each side is named by using the two letters at each end. We can also name the sides;  $\overline{BA}$ ,  $\overline{CB}$ ,  $\overline{DC}$  and  $\overline{DA}$ .

Now look at these similar triangles.



$\triangle ABC$  is similar to  $\triangle DEF$ , because they are of the same shape but different sizes.

$$\begin{aligned}\angle A &= \angle D && \text{(marked } \angle \times \text{)} \\ \angle B &= \angle E && \text{(marked } \angle \bullet \text{)} \\ \angle C &= \angle F && \text{(marked } \angle \frown \text{)}\end{aligned}$$

The two triangles have three pairs of equal corresponding angles. They also have 3 pairs of corresponding sides.

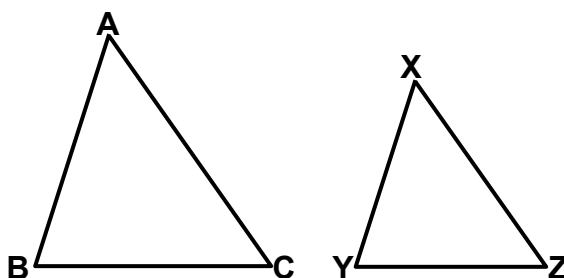
$$\begin{aligned}\text{Side } \overline{AB} &\text{ corresponds to Side } \overline{DE} \\ \text{Side } \overline{AC} &\text{ corresponds to Side } \overline{DF} \\ \text{Side } \overline{BC} &\text{ corresponds to Side } \overline{EF}\end{aligned}$$

They are corresponding sides because their relative positions are the same in both triangles (they are in matching positions in both triangles). But the corresponding sides are **not equal** because one triangle is bigger than the other triangle.

**Corresponding sides are sides that have the same relative positions in both triangles.**

## Example

In the figure, triangles ABC and XYZ are similar.



The relative positions of  $\overline{AB}$  and  $\overline{XY}$  are the same, so they are corresponding sides. Similarly,  $\overline{BC}$  and  $\overline{YZ}$ , and  $\overline{AC}$  and  $\overline{XZ}$ , are corresponding sides.

We write

$$\overline{AB} \text{ corresponds to } \overline{XY}$$

$$\overline{BC} \text{ corresponds to } \overline{YZ}$$

$$\overline{AC} \text{ corresponds to } \overline{XZ}$$
**REMEMBER:**

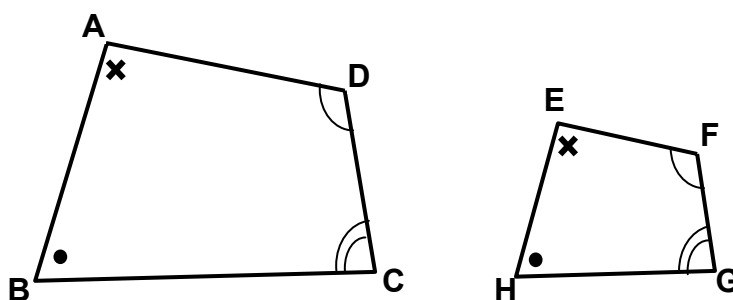
**The corresponding angles in similar shapes are equal.**

**The corresponding sides in similar shapes are usually not equal.**



In the same way, you can find corresponding angles and sides in other similar polygons.

Look at the quadrilaterals below.



Quadrilateral ABCD is similar to Quadrilateral EFGH because they have the same shape but different sizes. So,

$$\begin{aligned} \angle A &= \angle E && \text{(marked } \times \text{)} \\ \angle B &= \angle H && \text{(marked } \bullet \text{)} \\ \angle C &= \angle G && \text{(marked } \frown \text{)} \\ \angle D &= \angle F && \text{(marked } \smile \text{)} \end{aligned}$$

There are four (4) pairs of corresponding angles.

There are also four (4) pairs of corresponding sides.

$\overline{AB}$  corresponds to  $\overline{EH}$

$\overline{AD}$  corresponds to  $\overline{EF}$

$\overline{BC}$  corresponds to  $\overline{HG}$

$\overline{DC}$  corresponds to  $\overline{FG}$

The corresponding sides are in relative or matching positions on similar quadrilaterals.

The corresponding sides are usually **not equal** because the quadrilaterals are usually of different sizes.

**REMEMBER:**

**The corresponding angles and sides of similar shapes are pairs of matching angles and sides that are in the same position in the shapes.**

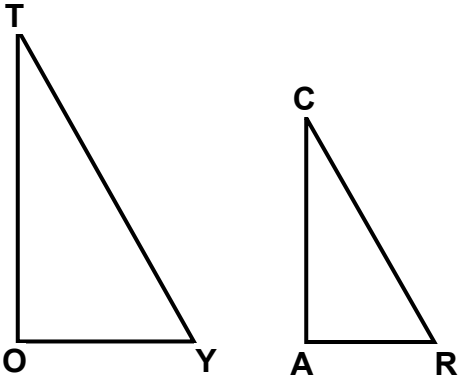
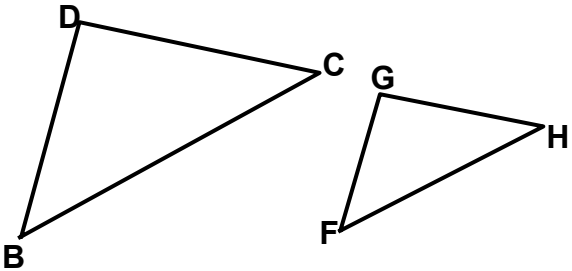
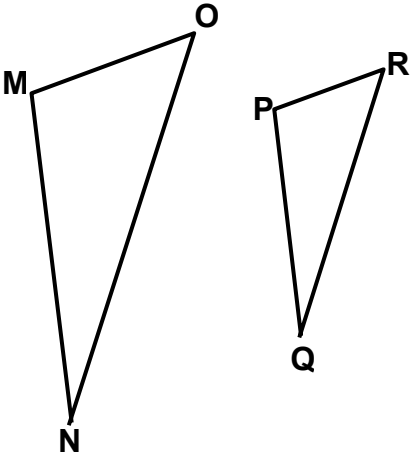
---

**NOW DO PRACTICE EXERCISE 14**



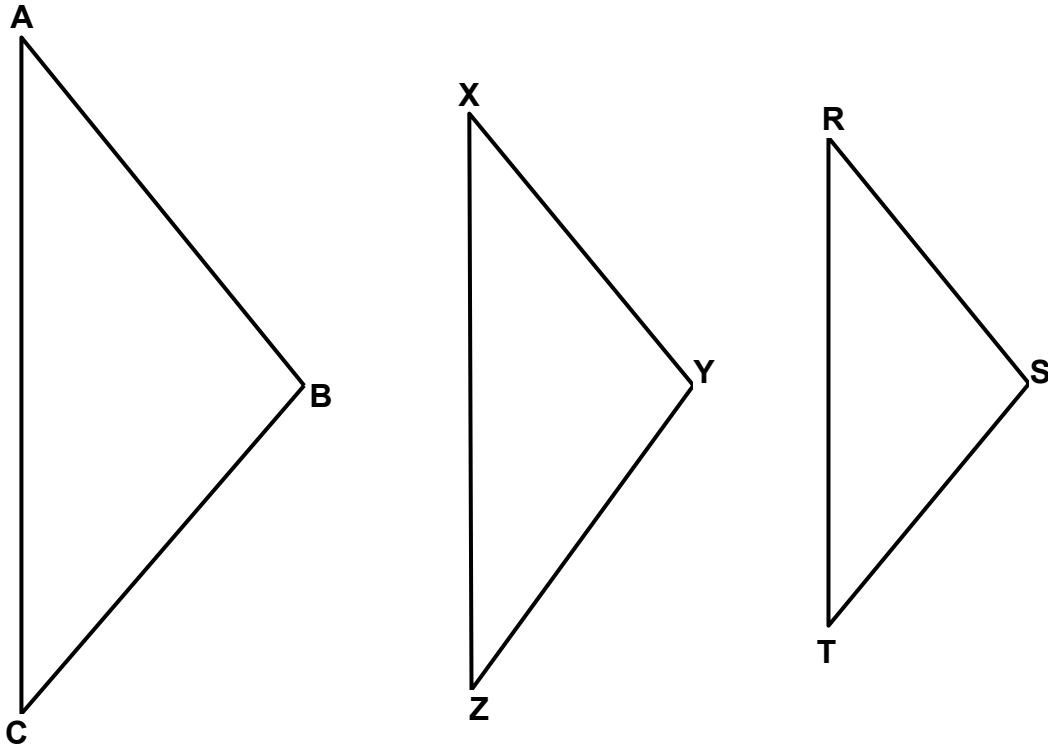
## Practice Exercise 14

1. Write down the corresponding angles in the following pairs of similar triangles. The first one is done for you.

SIMILAR TRIANGLES	CORRESPONDING ANGLES
<p>a)</p> 	<p><math>\angle T</math> corresponds to <math>\angle C</math>  <math>\angle O</math> _____ to <math>\angle A</math>  <math>\angle Y</math> _____ to _____</p>
<p>b)</p> 	<p><math>\angle D</math> corresponds to _____  <math>\angle B</math> _____ to _____  <math>\angle C</math> _____ to _____</p>
<p>c)</p> 	<p><math>\angle M</math> _____ to _____  <math>\angle N</math> _____ to _____  <math>\angle O</math> _____ to _____</p>

2. Three triangles are drawn below.  $\triangle ABC$  is similar to one of the other two triangles.

Which one is it? Use your protractor to measure the corresponding angles.



Size of angles in  $\triangle ABC$

$$\angle A = 40^\circ$$

$$\angle B = \underline{\hspace{2cm}}$$

$$\angle C = \underline{\hspace{2cm}}$$

Size of angles in  $\triangle XYZ$

$$\angle X = \underline{\hspace{2cm}}$$

$$\angle Y = \underline{\hspace{2cm}}$$

$$\angle Z = \underline{\hspace{2cm}}$$

Size of angles in  $\triangle RST$

$$\angle R = \underline{\hspace{2cm}}$$

$$\angle S = \underline{\hspace{2cm}}$$

$$\angle T = \underline{\hspace{2cm}}$$

You find that  $\triangle ABC$  is similar to  $\triangle$  \_\_\_\_\_

Because,  $\angle A = \angle$  \_\_\_\_\_

$$\angle B = \angle$$
 \_\_\_\_\_

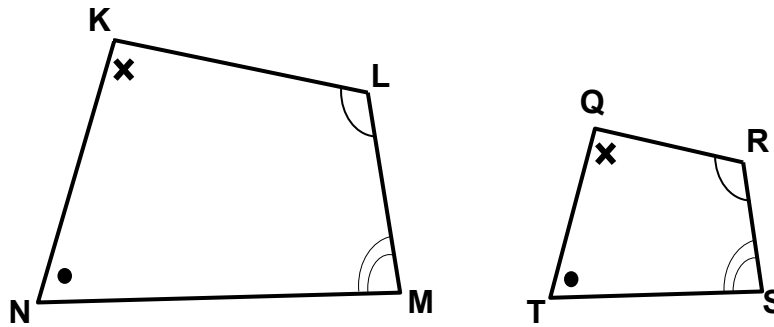
$$\angle C = \angle$$
 \_\_\_\_\_



3. List the three (3) pairs of corresponding sides in the similar triangles below. The first one is done for you.

SIMILAR TRIANGLES	CORRESPONDING SIDES
<p>a)</p>	<p><math>\overline{BD}</math> corresponds to <math>\overline{FG}</math>  <math>\overline{DC}</math> corresponds to <math>\overline{GH}</math>  <math>\overline{BC}</math> corresponds to <math>\overline{FH}</math></p>
<p>b)</p>	<p><math>\overline{DM}</math> corresponds to _____  <math>\overline{MC}</math> corresponds to _____  <math>\overline{DC}</math> corresponds to _____</p>
<p>c)</p>	<p><math>\overline{UV}</math> corresponds to _____  <math>\overline{VT}</math> corresponds to _____  <math>\overline{TU}</math> corresponds to _____</p>

4. Refer to the two similar quadrilaterals below and answer questions a to c.



- a) Name the two quadrilaterals.

**Answers:** Quadrilaterals \_\_\_\_\_ and \_\_\_\_\_

- b) List down 4 pairs of equal corresponding angles in the two similar quadrilaterals.

**Answers:**

1.  $\angle$  \_\_\_\_\_ =  $\angle$  \_\_\_\_\_
2.  $\angle$  \_\_\_\_\_ =  $\angle$  \_\_\_\_\_
3.  $\angle$  \_\_\_\_\_ =  $\angle$  \_\_\_\_\_
4.  $\angle$  \_\_\_\_\_ =  $\angle$  \_\_\_\_\_

- c) List down 4 pairs of corresponding sides in the two similar quadrilaterals.

**Answers:**

1. \_\_\_\_\_ corresponds to \_\_\_\_\_
2. \_\_\_\_\_ corresponds to \_\_\_\_\_
3. \_\_\_\_\_ corresponds to \_\_\_\_\_
4. \_\_\_\_\_ corresponds to \_\_\_\_\_

**CORRECT YOUR WORK. ANSWERS ARE AT THE END OF SUB-STRAND 3.**

## Lesson 15: Corresponding Angles and Sides (Part 2)



In the last lesson, we defined the term „corresponding“ as used in geometry and worked out corresponding angles and sides of similar triangles and polygons.



In this lesson, you will:

- identify corresponding angles and sides of similar shapes drawn in different positions.

You learnt and know that corresponding angles and sides of similar shapes are pairs of matching angles and sides that are in the same position in the shapes.

Now, you will learn how to identify corresponding angles and sides in some harder examples where the position of the shapes is different.



Can the position of the shapes affect the similarities?

The position of a shape may change but the angles and the sides remain unchanged.

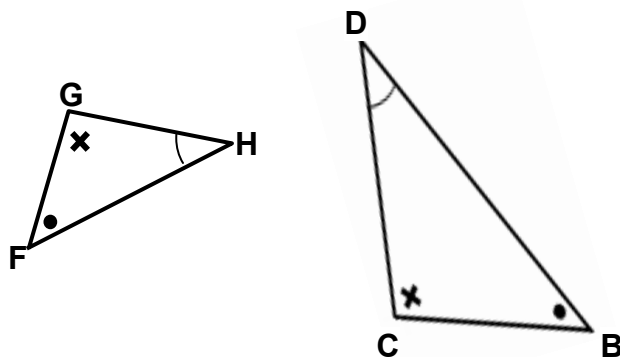
For example:

There are two tables in one room with similar shapes. One of the tables is moved to another room. What happens? (Think about it.)



The position of the table changes but its properties remain.

The same idea can be applied to similar shapes. Having this in mind, let us look at the two triangles below.



These two triangles have 3 pairs of equal angles.

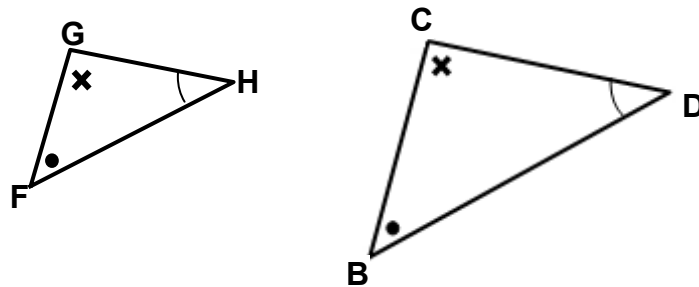
$$\angle G = \angle C \text{ (marked } \triangle \text{)}$$

$$\angle F = \angle B \text{ (marked } \bullet \text{)}$$

$$\angle H = \angle D \text{ (marked } \triangle \text{)}$$

So, the triangles must be similar; they must have the same shape.

Therefore, the pairs of equal angles are corresponding angles. We can see this clearly, if we change the position of one of the triangles.



Now we can see that

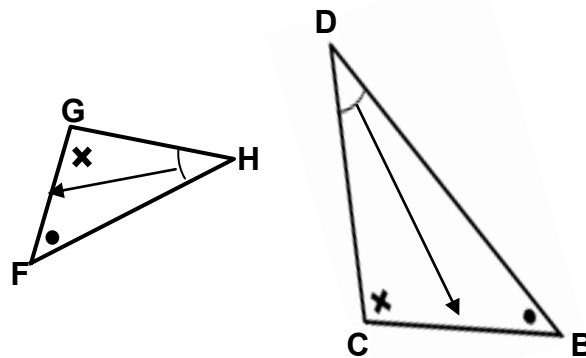
$\angle F$  corresponds to  $\angle B$

$\angle G$  corresponds to  $\angle C$

$\angle H$  corresponds to  $\angle D$

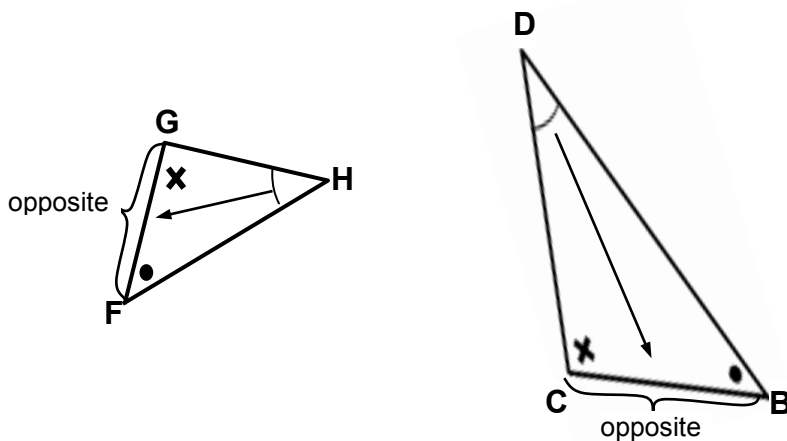
So,  $\Delta FGH$  is similar to  $\Delta BCD$  because it has the same shape, but a different size and all the corresponding angles are equal.

Let us, look at the two triangles again from the previous page.



In similar triangles the corresponding sides are opposite (across) the equal angles.

For example:  $\angle H = \angle D$  so, the side opposite  $\angle H$  corresponds to the side opposite  $\angle D$ .



The opposite side of  $\angle H$  is side  $\overline{FG}$  and the opposite side of  $\angle D$  is side  $\overline{BC}$ .

So,  $\overline{FG}$  corresponds with  $\overline{BC}$  because they are in matching positions in the two similar triangles.



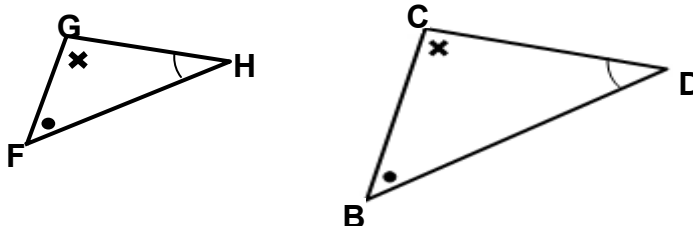
Which side corresponds to  $\overline{FH}$ ?

$\overline{FH}$  is opposite to  $\angle G$ . The side opposite the  $\angle C$  is  $\overline{BD}$ .



So,  $\overline{FH}$  corresponds to  $\overline{BD}$ . Also  $\overline{GH}$  corresponds to  $\overline{CD}$ . This is because they are opposite the corresponding angles  $\angle F$  and  $\angle B$ .

So for the corresponding sides we can see this well, if we change the position of one of the triangles.



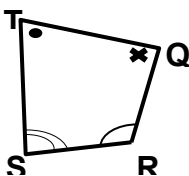
So we can see that

$\overline{FG}$  corresponds to  $\overline{BC}$  (opposite of  $\angle H$  and  $\angle D$ )

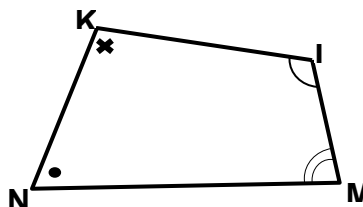
$\overline{GH}$  corresponds to  $\overline{CD}$  (opposite of  $\angle F$  and  $\angle B$ )

$\overline{FH}$  corresponds to  $\overline{BD}$  (opposite of  $\angle G$  and  $\angle C$ )

Now look at the two quadrilaterals below:



Quadrilateral QRST



Quadrilateral KLMN

The two quadrilaterals are similar because they have the same shape but are different sizes.

1) Let us list the corresponding vertices where you see equal angles.



What are vertices?

Vertices are the points or corners where two sides meet.



The corresponding vertices are:

- T corresponds to N ( $\angle T$  and  $\angle N$  are both marked )  $\sphericalangle$
- Q corresponds to K ( $\angle Q$  and  $\angle K$  are both marked )  $\sphericalangle$
- R corresponds to L ( $\angle R$  and  $\angle L$  are both marked )  $\sphericalangle$
- S corresponds to M ( $\angle S$  and  $\angle M$  are both marked )  $\sphericalangle$

Note: In some problems, equal angles are not marked. You may have to use your protractor to find out which angles are equal.

- 2) List the corresponding sides which are between the corresponding vertices.

So, the corresponding sides are:

$\overline{TQ}$  and  $\overline{NK}$  (corresponding vertices are T & N, Q & K)

$\overline{QR}$  and  $\overline{KL}$  (corresponding vertices are Q & K, R & L)

$\overline{RS}$  and  $\overline{LM}$  (corresponding vertices are R & L, S & M)

$\overline{ST}$  and  $\overline{MN}$  (corresponding vertices are S & M, T & N)

---

**NOW DO PRACTICE EXERCISE 15**



### Practice Exercise 15

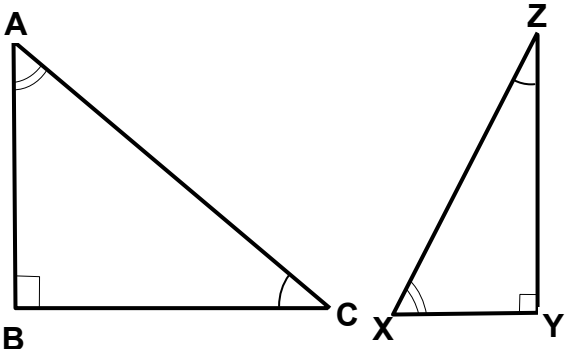
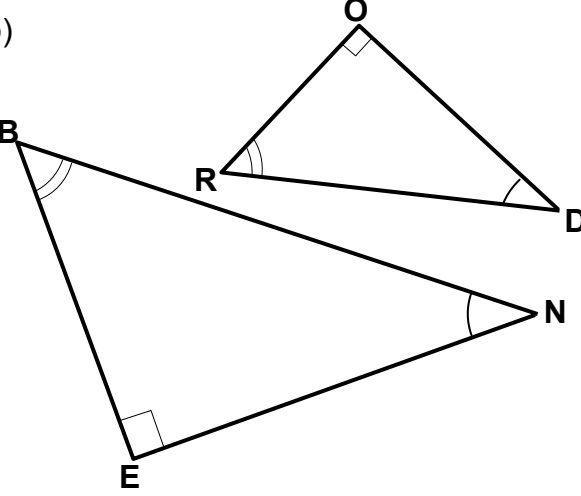
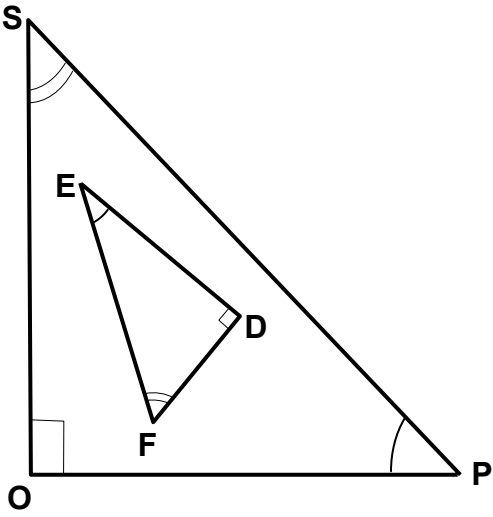
1. List all the corresponding equal angles in the triangles below.

Are the triangles similar? The first one is done for you.

TRIANGLES	CORRESPONDING ANGLES	SIMILAR
<p>a)</p>	<p><math>\angle A</math> corresponds to <math>\angle D</math>  <math>\angle B</math> corresponds to <math>\angle E</math>  <math>\angle C</math> corresponds to <math>\angle F</math></p>	<p>YES</p>
<p>b)</p>	<p><math>\angle J</math> corresponds to <math>\angle</math> _____  <math>\angle E</math> _____ <math>\angle</math> _____  <math>\angle T</math> _____ <math>\angle</math> _____</p>	<p>_____</p>
<p>c)</p>	<p><math>\angle U</math> corresponds to <math>\angle</math> _____  <math>\angle V</math> _____ <math>\angle</math> _____  <math>\angle W</math> _____ <math>\angle</math> _____</p>	<p>_____</p>

2. List the equal angles in the similar triangles below then list the corresponding sides opposite the equal angles.

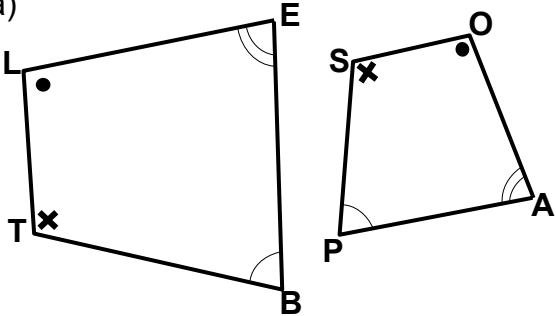
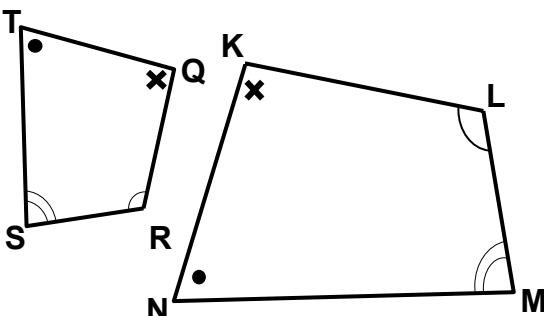
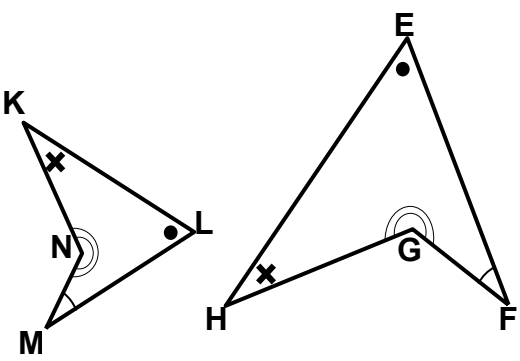
The first one is done for you.

SIMILAR TRIANGLES	EQUAL ANGLES	CORRESPONDING SIDES
<p>a)</p> 	$\angle A = \angle X$ $\angle B = \angle Y$ $\angle C = \angle Z$	$\overline{BC}$ corresponds to $\overline{YZ}$ $\overline{AC}$ corresponds to $\overline{XZ}$ $\overline{AB}$ corresponds to $\overline{XY}$
<p>b)</p> 	$\angle N = \angle \underline{\hspace{1cm}}$ $\angle E = \angle \underline{\hspace{1cm}}$ $\angle B = \angle \underline{\hspace{1cm}}$	$\overline{BE}$ corresponds to $\underline{\hspace{1cm}}$ $\overline{BN}$ $\underline{\hspace{1cm}}$ $\underline{\hspace{1cm}}$ $\overline{EN}$ $\underline{\hspace{1cm}}$ $\underline{\hspace{1cm}}$
<p>c)</p> 	$\angle O = \angle \underline{\hspace{1cm}}$ $\angle S = \angle \underline{\hspace{1cm}}$ $\angle P = \angle \underline{\hspace{1cm}}$	$\overline{SP}$ $\underline{\hspace{1cm}}$ $\underline{\hspace{1cm}}$ $\overline{OP}$ $\underline{\hspace{1cm}}$ $\underline{\hspace{1cm}}$ $\overline{SO}$ $\underline{\hspace{1cm}}$ $\underline{\hspace{1cm}}$



3. List the equal angles in the similar polygons below and then list the corresponding sides.

The first one is done for you.

SIMILAR POLYGONS	EQUAL ANGLES	CORRESPONDING SIDES
<p>a)</p> 	$\angle L = \angle O$ $\angle E = \angle A$ $\angle B = \angle P$ $\angle T = \angle S$	$\overline{LE}$ corresponds to $\overline{OA}$ $\overline{EB}$ corresponds to $\overline{AP}$ $\overline{BT}$ corresponds to $\overline{PS}$ $\overline{TL}$ corresponds to $\overline{SO}$
<p>b)</p> 	$\angle T = \angle N$ $\angle S = \angle \underline{\hspace{1cm}}$ $\angle Q = \angle \underline{\hspace{1cm}}$ $\angle R = \angle \underline{\hspace{1cm}}$	$\overline{TQ}$ corresponds to $\underline{\hspace{1cm}}$ $\overline{QR}$ $\underline{\hspace{1cm}}$ $\overline{RS}$ $\underline{\hspace{1cm}}$ $\overline{ST}$ $\underline{\hspace{1cm}}$
<p>c)</p> 	$\angle K = \angle \underline{\hspace{1cm}}$ $\angle N = \angle \underline{\hspace{1cm}}$ $\angle M = \angle \underline{\hspace{1cm}}$ $\angle L = \angle \underline{\hspace{1cm}}$	$\overline{KL}$ $\underline{\hspace{1cm}}$ $\overline{LM}$ $\underline{\hspace{1cm}}$ $\overline{MN}$ $\underline{\hspace{1cm}}$ $\overline{NK}$ $\underline{\hspace{1cm}}$

**CORRECT YOUR WORK. ANSWERS ARE AT THE END OF SUB-STRAND 3.**

## Lesson 16: Drawing Similar Triangles



In the previous lessons you learnt how to work out corresponding angles and sides of similar triangles and polygons.



In this lesson, you will:

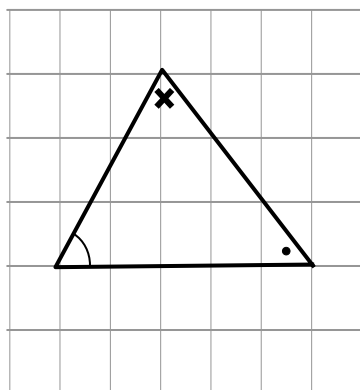
- define enlargement and reduction
- identify the centre of enlargement of similar shapes
- draw similar triangles.

You know that for two figures to be similar, all matching or corresponding angles must be equal and that sides are in corresponding positions.

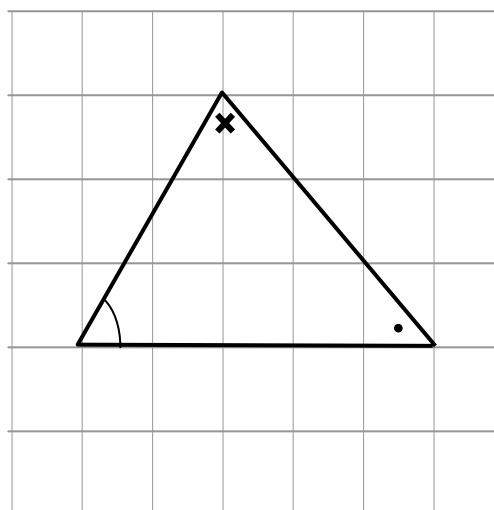
Now you will be looking at ways to draw similar triangles and shapes.

### 1. Using different sized grids

Look at these two triangles.



**TRIANGLE 1**



**TRIANGLE 2**

The two triangles have 3 pairs of equal corresponding angles. So they are similar.

Triangle 1 has been drawn on a small grid.

Triangle 2 has been drawn on a larger grid, with the same number of spaces between the vertices.

We say we have made an enlargement of Triangle 1. The result is Triangle 2.

What is an enlargement?



**Enlargement is the result we get when we make an object or a shape larger (or bigger).**

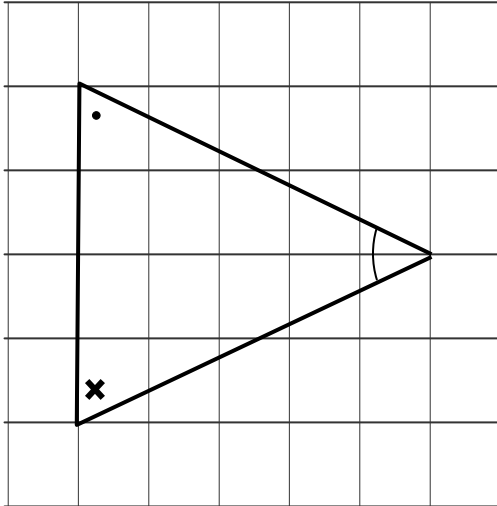


Can we also make triangles using smaller grid?

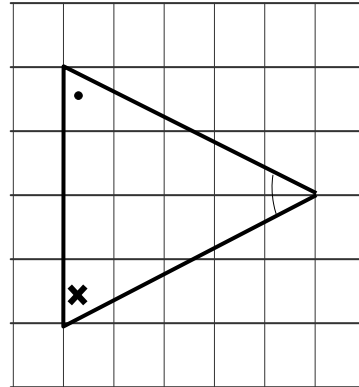
Yes. if we use a smaller grid, we get a smaller triangle.



Now look at these two triangles.



**USING LARGE GRID**



**USING SMALL GRID**

The two triangles have 3 pairs of equal corresponding angles. So, they are similar.

The first triangle has been drawn on a large grid.

The second triangle has been drawn on a smaller grid, with the same number of spaces between the vertices.

We say, we have made a reduction of the first triangle, and the result is the second triangle.

What is a reduction?

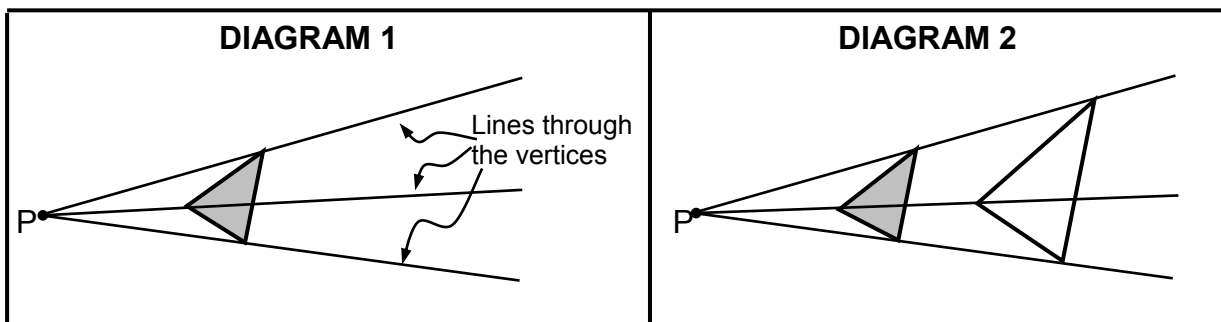


**A reduction is the result we get when we make an object or a shape smaller (reduce it).**

We say, reduction is the opposite of enlargement.

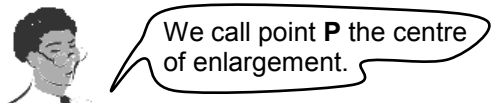
**2. Using the Centre of Enlargement**

Look at the two diagrams below.

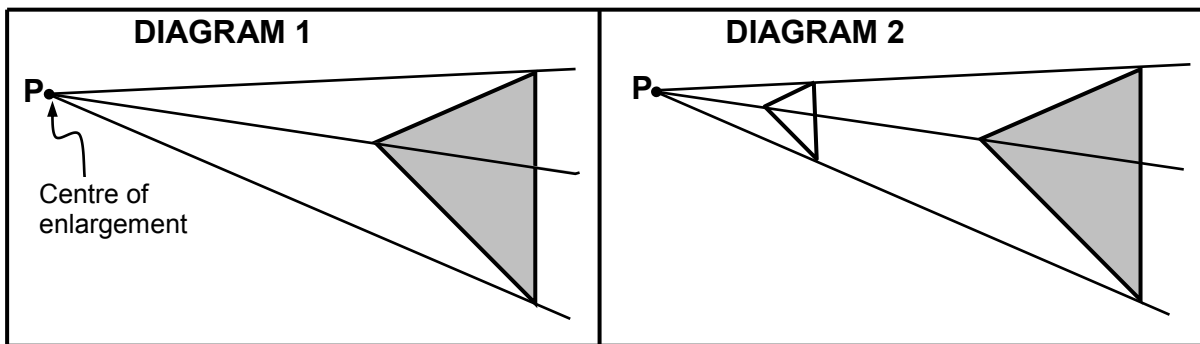
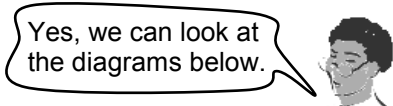
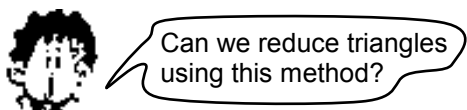


**DIAGRAM 1** has a small triangle, and a point called **P** outside the triangle. We have drawn thin lines from **P** through the three (3) vertices of the small triangle.

**DIAGRAM 2** has the same small triangle, with a large one beside it. The larger one has been drawn by using the thin lines from **P**. All the three (3) vertices of the larger triangle are on the thin lines and are twice as far as the vertices of the small triangle (measure with your ruler).



**The Centre of Enlargement is a point which can be used to draw similar shapes.**



**DIAGRAM 1** has a large triangle, and a point called **P** outside the triangle. (We will still call **P** the centre of enlargement). Thin lines are drawn from **P** through the 3 vertices of the large triangle.

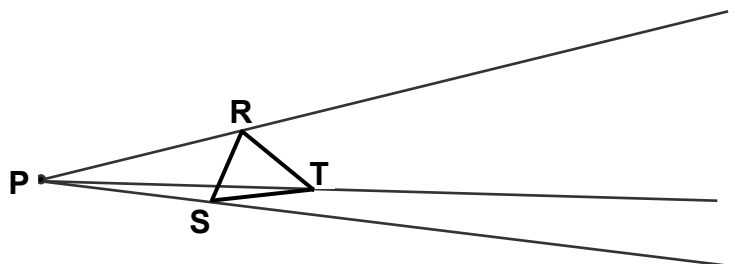
**DIAGRAM 2** has the same triangle with a smaller one next to it. The smaller triangle has been drawn by using the thin lines from **P**. All 3 vertices of the smaller triangle are on the thin lines. All the 3 vertices of the small triangle are one-third of the distance from **P** as the vertices of the large triangle (measure with your ruler).

If you check the corresponding angles of the triangles we drew using the centre of enlargement, you will find that the corresponding angles are equal. So, the triangles are similar.

Now you will use a centre of enlargement to draw similar triangles.

**Example 1**

Use the centre of enlargement **P** to draw a larger triangle similar to  $\Delta SRT$  below. Make all the vertices 3 times as far from **P** as the vertices of  $\Delta SRT$ .



Let us look at the steps below on how to draw a larger triangle similar to  $\Delta SRT$ .

- Step 1 Measure the distance from P to vertex S. It is 2 cm.  
 Step 2 Multiply your answer by 3. ( $3 \times 2 \text{ cm} = 6 \text{ cm}$ ).  
 Step 3 Mark the first vertex of your similar triangle on the same thin line, 6 cm from P. Call this point S'' (read as S prime).

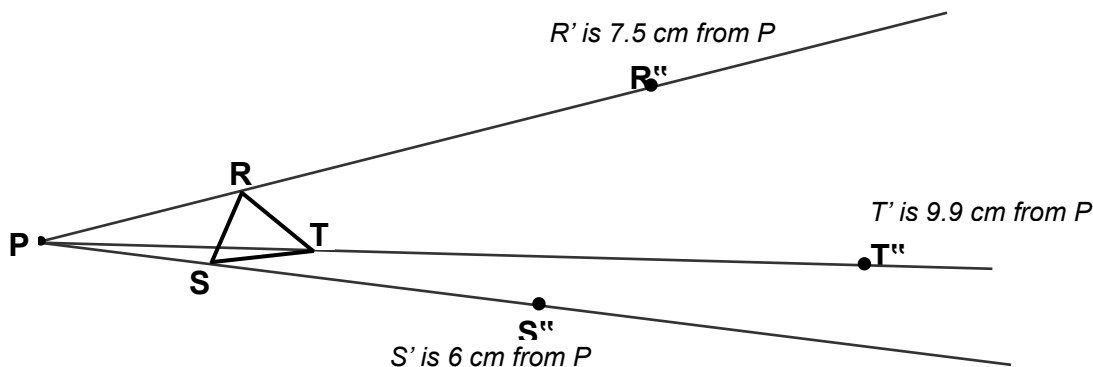
Now repeat the 3 steps again to find the second vertex.

- Step 1 Measure the distance from P to vertex R. It is 2.5 cm.  
 Step 2 Multiply your answer by 3. ( $3 \times 2.5 \text{ cm} = 7.5 \text{ cm}$ ).  
 Step 3 Mark the first vertex of your similar triangle on the same thin line, 7.5 cm from P. Call this point R'' (read as R prime).

Now repeat the 3 steps again to find the last vertex.

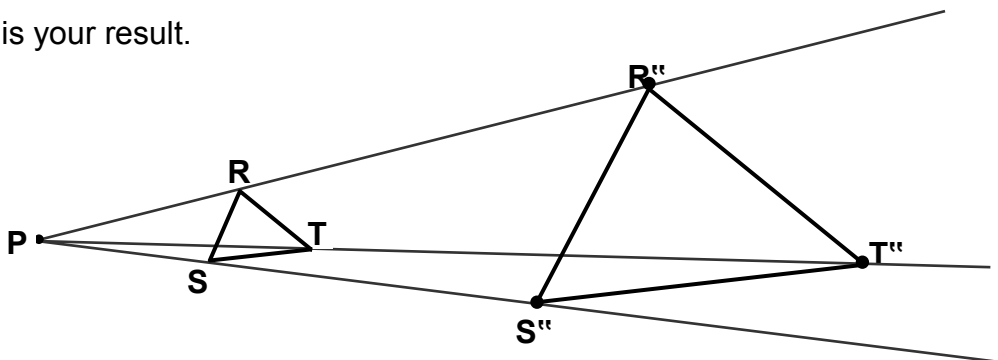
- Step 1 Measure the distance from P to vertex T. It is 3.3 cm.  
 Step 2 Multiply your answer by 3. ( $3 \times 3.3 \text{ cm} = 9.9 \text{ cm}$ ).  
 Step 3 Mark the first vertex of your similar triangle on the same thin line, 9.9 cm from P. Call this point T'' (read as R prime).

Here are the positions of the 3 vertices of your similar triangle. They are the points S'', R'' and T''.



Lastly, join the 3 vertices S'', R'' and T'' to make a triangle which is similar to  $\Delta SRT$ . It is the  $\Delta S''R''T''$ .

Here is your result.

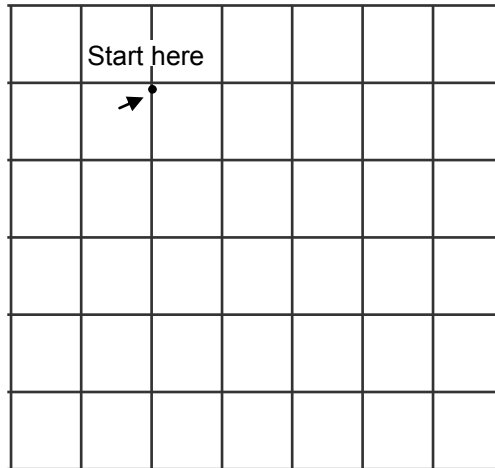
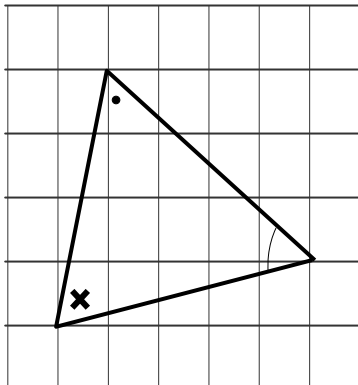


**NOW DO PRACTICE EXERCISE 16.**



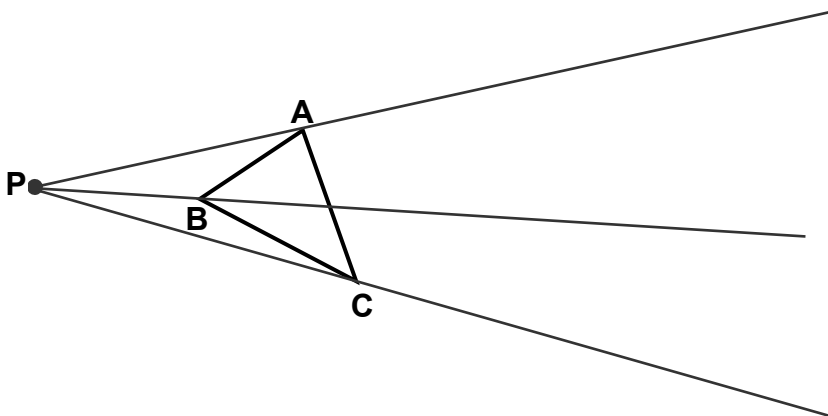
### Practice Exercise 16

1. a) Draw a triangle similar to the one below. Use the larger grid on the right.



- b) Check the corresponding angles with your protractor.  
 Are there 3 pairs of equal corresponding angles? **Answer:** \_\_\_\_\_
- c) Have you made an enlargement or reduction of the first triangle?  
**Answer:** \_\_\_\_\_

2. Use the centre of enlargement P to draw a larger triangle similar to  $\Delta ABC$  shown below. Make all the vertices 2 times as far as the vertices of  $\Delta ABC$ .



- Step 1 Measure the distance from P to vertex A. It is \_\_\_\_\_ cm.  
 Step 2 Multiply your answer by 2. ( $2 \times$  \_\_\_\_\_ cm = \_\_\_\_\_ cm).  
 Step 3 Mark the first vertex of your similar triangle on the same thin line, \_\_\_\_\_ cm from P. Call this point A".

Now repeat the 3 steps again to find the second vertex.

Step 1 Measure the distance from P to vertex B. It is \_\_\_\_\_ cm.

Step 2 Multiply your answer by 2. ( $2 \times$  \_\_\_\_\_ cm = \_\_\_\_\_ cm).

Step 3 Mark the first vertex of your similar triangle on the same thin line, \_\_\_\_\_ cm from P. Call this point B".

Now repeat the 3 steps again to find the last vertex.

Step 1 Measure the distance from P to vertex C. It is \_\_\_\_\_ cm.

Step 2 Multiply your answer by 2. ( $2 \times$  \_\_\_\_\_ cm = \_\_\_\_\_ cm).

Step 3 Mark the first vertex of your similar triangle on the same thin line, \_\_\_\_\_ cm from P. Call this point C".

Show the positions of the 3 vertices of your similar triangle in the space below. Join the vertices to make  $\Delta A''B''C''$ .



Check the 3 pairs of corresponding angles in  $\Delta ABC$  and  $\Delta A''B''C''$ .

Are the 3 pairs of corresponding angles equal?

Answer: \_\_\_\_\_

Are the triangles similar?

Answer: \_\_\_\_\_

---

**CORRECT YOUR WORK. ANSWERS ARE AT THE END OF SUB-STRAND 3.**

## Lesson 17: Drawing Similar Shapes



In the last lesson, you learnt about enlargement and reduction. You identified the centre of enlargement of similar shapes and drew similar triangles.



In this lesson you will

- draw more similar shapes other than triangles.

You are able to draw similar triangles using the centre of enlargement and different sized grid papers.

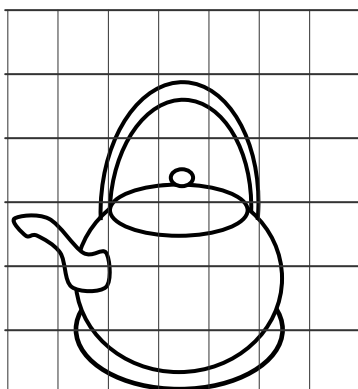
Now you will use the two methods to draw more similar shapes.

### 1. Different Sized Grids

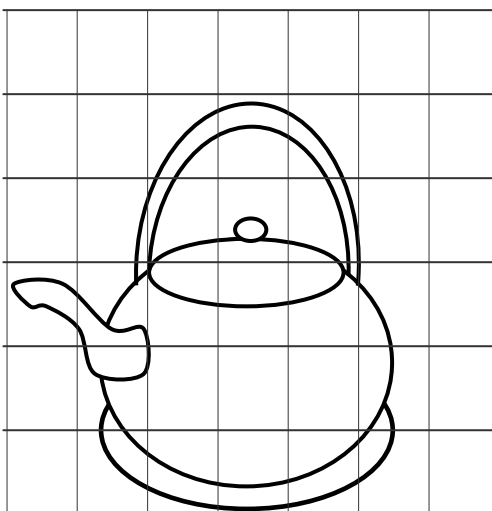
#### Example 1

Look at the two diagrams below.

The grids are of different sizes but the shapes are similar.



**DIAGRAM 1**



**DIAGRAM 2**

The shape in Diagram 2 is larger in size than the shape in Diagram 1.

We can enlarge a shape by drawing it again on a larger grid.

We say the shape in Diagram 2 is the enlargement of the shape in Diagram 1.

We can use different sized grids to make enlargements of any shape.

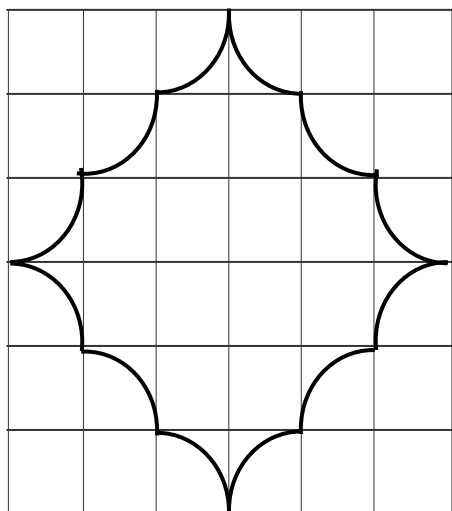
Artists sometimes use this method of different sized grids to enlarge or reduce shapes.

See other examples on the next page.

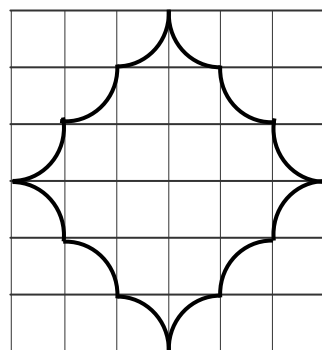


Here are another two diagrams.

**DIAGRAM 1**



**DIAGRAM 2**



The grids are of different sizes but the shapes are similar.

The shape in Diagram 2 is smaller in size than the shape in Diagram 1.

We can reduce a shape by drawing it again on a smaller grid.

We say the shape in Diagram 2 is a Reduction of the shape in Diagram 1.

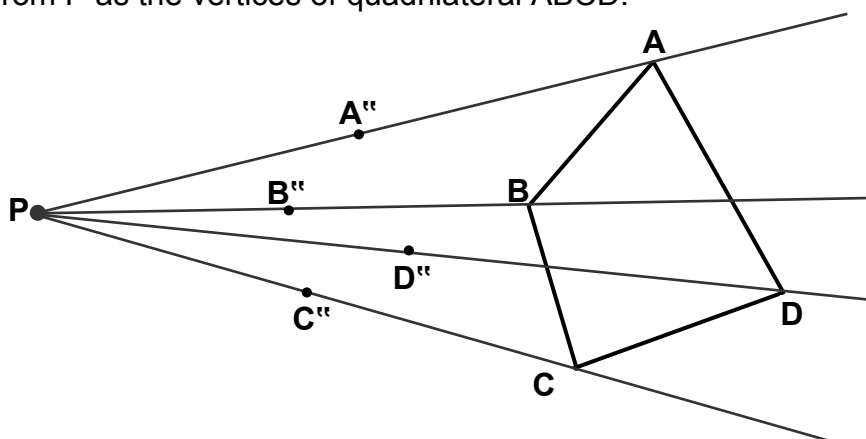
We can use different sized grids to make reductions of any shape.

## 2. Centre of Enlargement

We can also use the centre of enlargement to enlarge or reduce shapes.

Example

Use the centre of enlargement  $P$  to reduce quadrilateral  $ABCD$  to make another smaller quadrilateral  $A''B''C''D''$ . Make the vertices of quadrilateral  $A''B''C''D''$  half the distance from  $P$  as the vertices of quadrilateral  $ABCD$ .



Here is how to find the vertices of quadrilateral  $A''B''C''D''$ .

$PA$  is 10 cm, so  $PA''$  must be 5 cm (half of 10 cm)

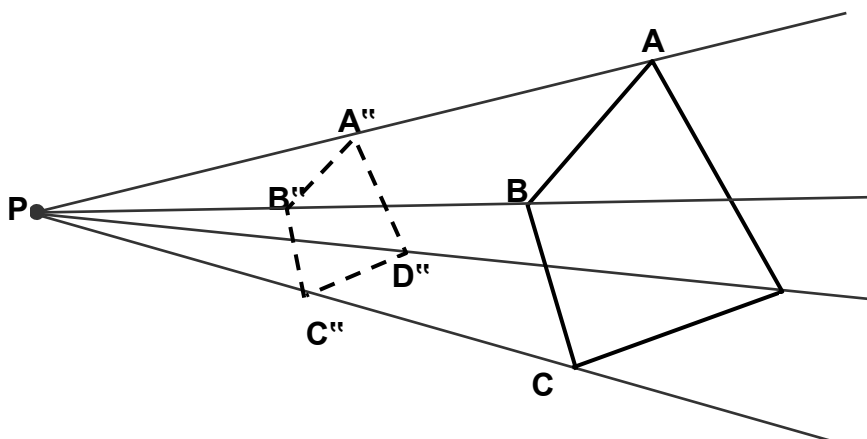
$PB$  is 8 cm, so  $PB''$  must be 4 cm (half of 8 cm)

$PC$  is 9 cm, so  $PC''$  must be 4.5 cm (half of 9 cm)

$PD$  is 12 cm, so  $PD''$  must be 6 cm (half of 12 cm)

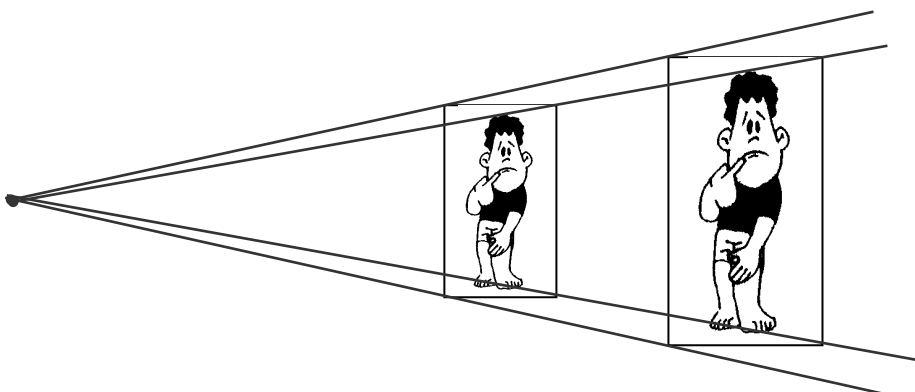
Now join the vertices  $A''$ ,  $B''$ ,  $C''$  and  $D''$  using dotted lines to make the quadrilateral  $A''B''C''D''$ .

You have drawn Quadrilateral  $A''B''C''D''$  which is similar to Quadrilateral  $ABCD$ .



Measure the corresponding angles of both quadrilaterals. You should find 4 pairs of equal corresponding angles.

Here are some uses of enlargement and reduction of shapes in daily life.



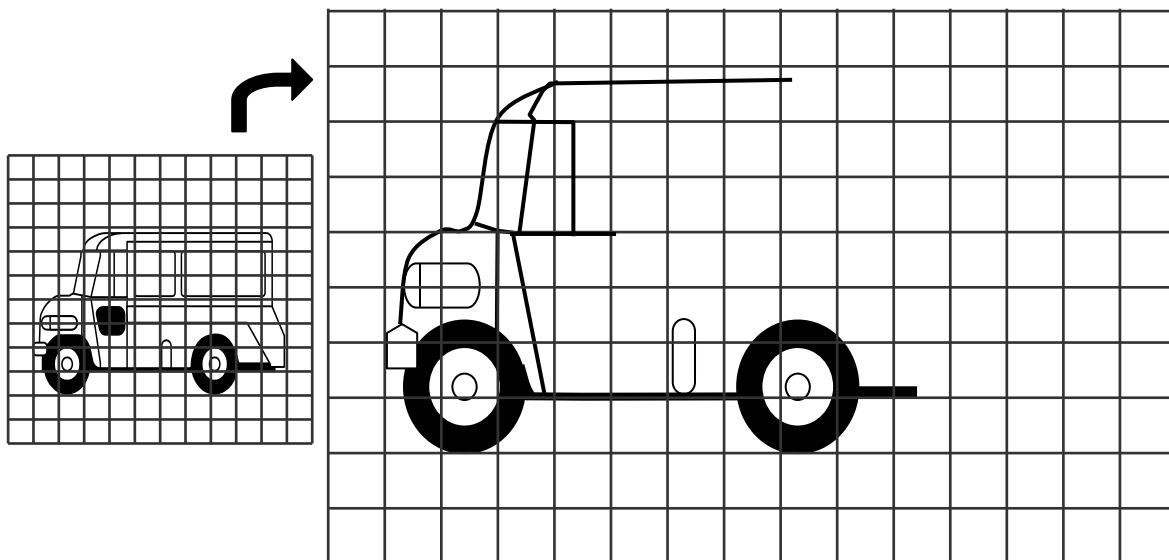
Enlargement and reduction occurs when a photograph is enlarged, a film is projected onto a screen, a scale drawing is made or a microscope is used.

**NOW DO PRACTICE EXERCISE 17.**

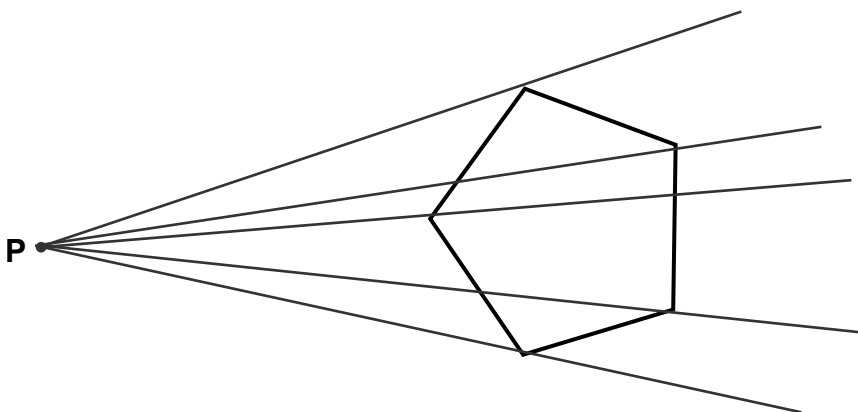


### Practice Exercise 17

1. Use a pencil to copy the drawing from the small grid onto the large grid. Do not hurry to finish; just carefully copy one square at a time. Some parts have been drawn for you.



2. Use the centre of enlargement P to REDUCE the polygon below. Make all the vertices of the smaller polygon half the distance from P as the vertices of the large polygon.



WORKING:

PG is 7 cm, so PG" must be      cm (half of 7 cm)

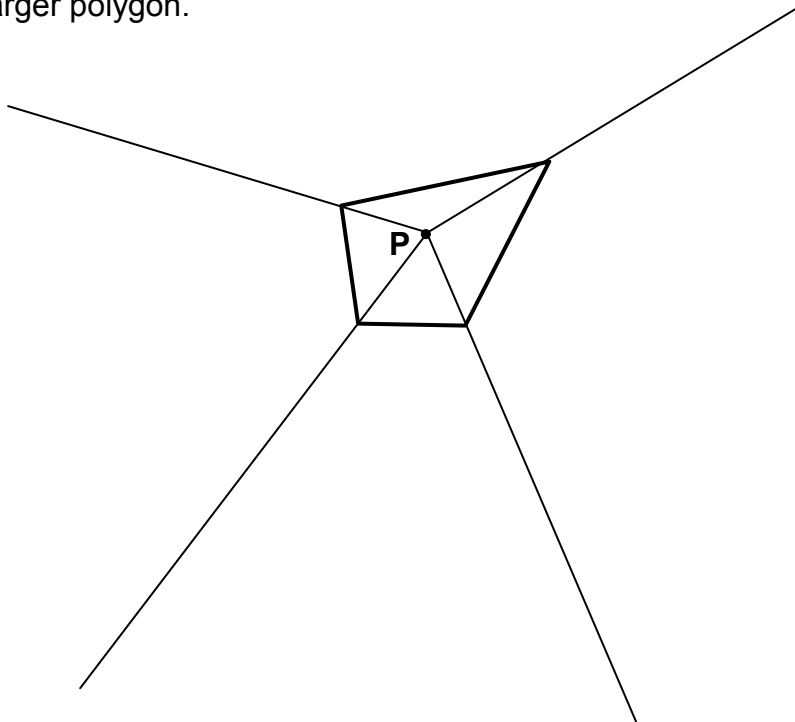
PL is      cm, so PL" must be      cm (half of      cm)

PO is      cm, so PO" must be      cm (half of      cm)

PR is      cm, so PR" must be      cm (half of      cm)

PY is      cm, so PY" must be      cm (half of      cm)

3. Use the centre of enlargement P to ENLARGE the polygon below. Make all the vertices of the smaller polygon half the distance from P as the vertices of the larger polygon.



WORKING:

PL is 1 cm, so PL'' is \_\_\_\_\_ cm (3 x 1 cm)

PO is \_\_\_\_\_ cm, so PO'' is \_\_\_\_\_ cm (3 x \_\_\_\_\_ cm)

PV is \_\_\_\_\_ cm, so PV'' is \_\_\_\_\_ cm (3 x \_\_\_\_\_ cm)

PE is \_\_\_\_\_ cm, so PE'' is \_\_\_\_\_ cm (3 x \_\_\_\_\_ cm)

---

**CORRECT YOUR WORK. ANSWERS ARE AT THE END OF SUB-STRAND 3.**

## Lesson 18: Scale Drawing



In the last lesson, you drew more similar shapes by enlargement and reduction using different sized grids and the centre of enlargement.



In this lesson you will:

- define what a scale drawing is
- draw similar shapes using the scale for length
- find and read information from a scale drawing and
- make scale drawings.

Scale drawings are used often in everyday life. People such as architects and engineers make scale drawings of buildings and bridges. People such as builders must be able to read the scale drawing of these things so that they can build them.

What is a scale drawing?



- **Scale drawings have the same shapes as the objects they represent but they are different in size.**
- **A scale drawing is a drawing that shows a real object with accurate sizes except that they have all been reduced or enlarged by a certain amount called the SCALE.**
- **The scale is the ratio of the drawing length to the corresponding real length.**

**Scale = length on drawing : real length**

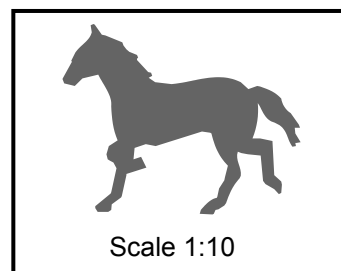
- **A scale is written by:**
  1. **writing corresponding measurement: 1 cm to 1 m**
  2. **using a simplified ratio; 1 : 100**
  3. **using a key number line, drawn to scale:**



For example



Real horse  
1500 mm high

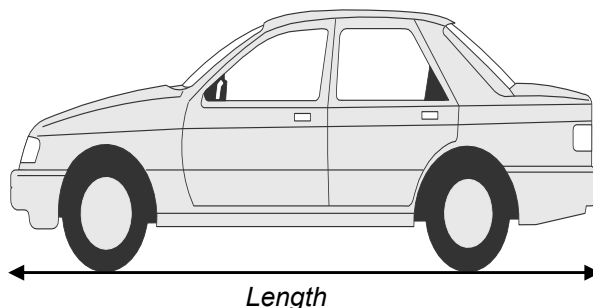


Drawn horse  
150 mm high

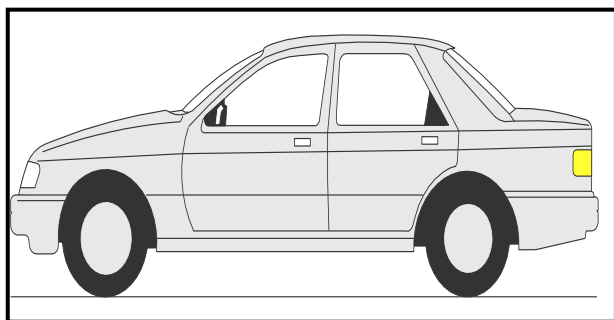
The drawing has a scale of 1:10, so anything drawn with the size of 1 would have a size of 10 in the real world. Therefore, a measurement of 150 mm on the drawing would be 1500 mm on the real horse.

**Note that the first number always refers to the length of the drawing on paper and the second number refers to the length of the real-life object.**

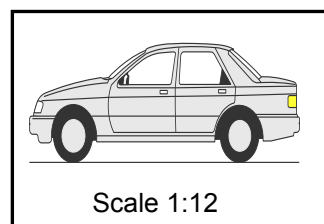
Since it is not always possible to draw on paper the actual size of real-life objects such as the real size of a car, an airplane, we need scale drawings to represent the size like the one you see below of a car.



In real-life, the length of this car may measure 360 cm. However, the length of a copy or print paper that you could use to draw this car is a little bit less than 30 cm.



Real car  
360 cm long



Drawn car  
30 cm

Solution:

Since  $\frac{360}{30} = 12$ , you will need about 30 sheets of copy paper to draw the height of the actual size of the car.

In order to use just one sheet, you could then use 1 cm on your drawing to represent 10 cm on the real-life object

You can write this situation as 1:12 or  $\frac{1}{12}$  or 1 to 12.

**The drawing has a scale of "1:12"**, so anything drawn with the size of 1 would have a size of 12 in the real world, so a measurement of 30 cm on the drawing would be 360 cm on the real car.

The scale determines the size of the drawing, the closer the size of terms in the scale ratio, the closer the drawing is to real size. So, **1:10** scale drawing would be bigger than a **1:100** scale drawing of the same object.

If the scale is 1:10 then the drawing has lengths  $\frac{1}{10}$  the lengths of the original.

If the scale is 1:100 then the lengths are  $\frac{1}{100}$  as long as the original.

**REMEMBER:**

**In scale drawing work there are only two types of problems;**

- 1. The first type involves making a scale drawing of the object**
- 2. The second type involves calculating the real sizes of the objects from the scale drawing.**

Here are other examples.

**Example 1**

Suppose a problem tells you that the length of a vehicle is drawn to scale. The scale of the drawing is 1:20

If the length of the drawing of the vehicle on paper is 12 cm, how long is the vehicle in real life?

Set up a proportion that will look like this:

$$\frac{\text{Height of drawing}}{\text{Real height}} = \frac{1}{20}$$

Do a cross product by multiplying the numerator of one fraction by the denominator of the other fraction

$$\frac{\text{Height of drawing}}{\text{Real height}} \times \frac{1}{20}$$

We get:

$$\text{Length of drawing} \times 20 = \text{Real length} \times 1$$

Since length of drawing = 12, we get

$$12 \times 20 = \text{Real length} \times 1$$

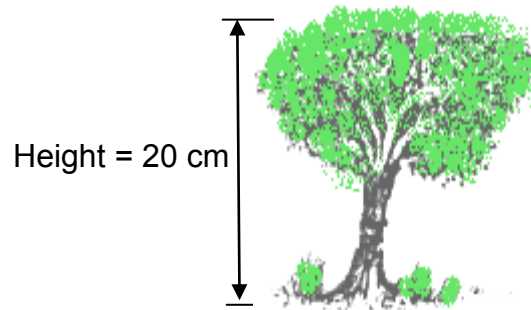
$$240 \text{ cm} = \text{Real length}$$

**Therefore, the car is 240 cm long in real life.**

## Example 2

The scale drawing of this tree is 1:500.

If the height of the tree on paper is 20 cm, what is the height of the tree in real life?



Set up a proportion like this:

$$\frac{\text{Height of drawing}}{\text{Real height}} = \frac{1}{500}$$

Do a cross product by multiplying the numerator of one fraction by the denominator of the other fraction.

$$\frac{\text{Height of drawing}}{\text{Real height}} \begin{array}{c} \swarrow \searrow \\ \nearrow \nwarrow \end{array} \frac{1}{500}$$

We get:

$$\text{Height of drawing} \times 500 = \text{Real height} \times 1$$

Since height of drawing = 20 cm, we get

$$20 \times 500 = \text{Real length} \times 1$$

$$10\,000 \text{ cm} = \text{Real height}$$

**Therefore, the height of the tree in real life is 10 000 cm.**



Now you will find out some of the uses of scale drawings.

Some uses of scale drawings are: architectural plans, engineering plans and maps.

Maps, plans and models match the shapes of the objects they represent, but are enlarged or reduced in size. They are drawn to scale, in proportion (similar) to the originals.



First we will look at examples of architectural (building) plans.

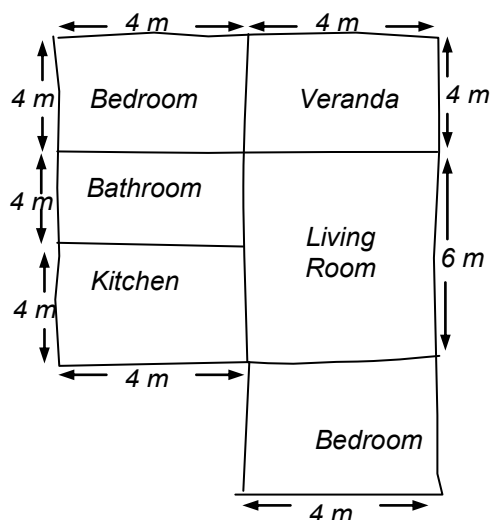
Before a building can be built, plans must be drawn. A plan will show details of the shape of the building. The shape of the drawing on the plan will be similar to the shape of the building. The plan will be a reduced drawing because it is smaller than the real building.



Follow the following steps to draw a plan.

Step 1: Make a rough sketch showing the shape of the rooms in the building.

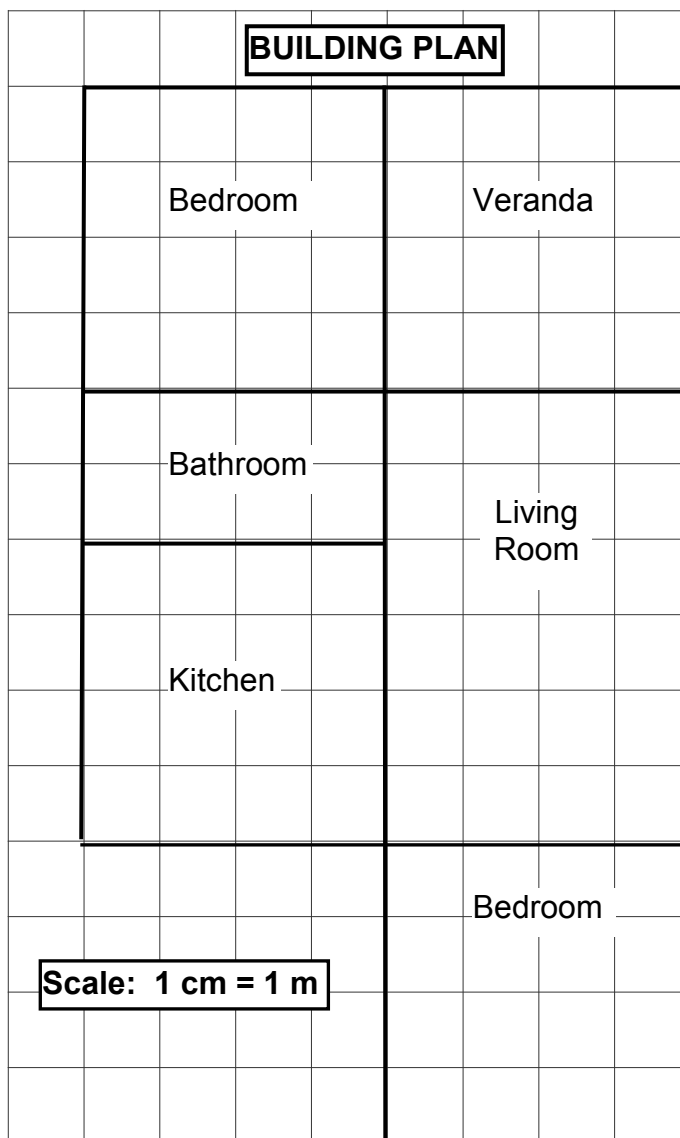
Step 2: Write the measurements of the rooms on the plan, like this below.



Step 3: Decide on a scale for your drawing. If you are using a one centimetre grid, you may use a scale of  $1\text{ cm} = 1\text{ m}$  for this plan.

Step 4: Draw your plan, using the scale. Every 1 cm on your plan represents 1 m on the building.

Step 5: Your result is shown in the diagram.

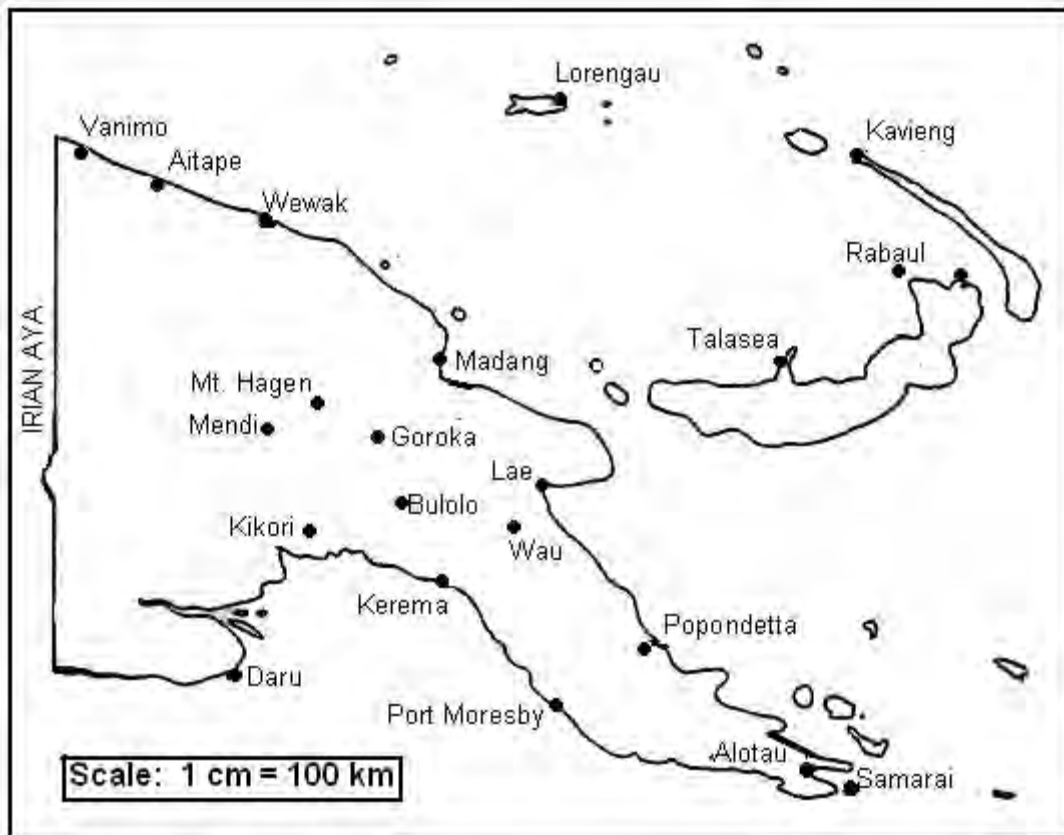


**Note:** There is no need to write the measurement on the plan, because every centimetre on the drawing represents 1 metre on the building.

We have written the scale as  $1\text{ cm} = 1\text{ m}$ . This is another way of writing the scale. Since 1 cm in the plan represents 1 m in the real building, we could also write the scale as 1: 100, because 1 cm on the plan represent 100 cm on the real building.

Now look at examples on how to use a given scale to find information from a scale drawing.

Look at this map which shows a portion of Papua New Guinea.



The map of PNG is the same shape as PNG, but different in size.

They are similar in shape.

Maps are scale drawings.

The map above is drawn using a scale of  $1\text{ cm} = 100\text{ km}$ .

We can use the scale to work out the real distance between the places on the map.

Example 1

What is the real distance between Mt. Hagen and Madang?

Step 1 Use your ruler to measure the distance on the map.

Distance from Mt. Hagen to Madang is **2** cm on the map.

Step 2 Use the scale shown on the map to work out the real distance.

Scale is  $1\text{ cm} = 100\text{ km}$

so,  $2\text{ cm} = 2 \times 100\text{ km}$

$= 200\text{ km}$

**Therefore, the distance from Mt. Hagen to Madang is 200 km.**

## Example 2

What is the actual distance from Port Moresby to Kavieng?

Step1 Measure the distance on the map using your ruler.

Distance from Port Moresby to Kavieng is 9 cm on the map.

Step 2 Use the scale shown on the map to work out the real distance.

Scale is 1 cm = 100 km

so, 9 cm = 9 x 100 km

= 900km

**Therefore, the distance from Port Moresby to Kavieng is 900 km.**

## Example 3

What is the actual distance from Lae to Mendi?

Step1 Measure the distance on the map using your ruler.

Distance from Lae to Mendi is 4.5 cm on the map.

Step 2 Use the scale shown on the map to work out the real distance.

Scale is 1 cm = 100 km

so, 4.5 cm = 4.5 x 100 km

= 450 km

**Therefore, the distance from Lae to Mendi is 450 km.**

---

**NOW DO PRACTICE EXERCISE 18.**



## Practice Exercise 18

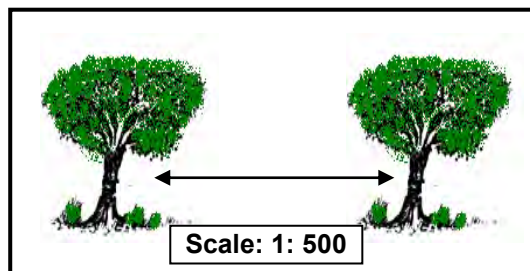
1. Copy and complete each of the following.

- a.  $1 \text{ cm} : 1 \text{ m} = 1 : \underline{\hspace{2cm}}$   
 b.  $1 \text{ mm} : 1 \text{ m} = 1 : \underline{\hspace{2cm}}$   
 c.  $1 \text{ m} : 1 \text{ km} = 1 : \underline{\hspace{2cm}}$

2. The scale on a drawing is 1:100. What is the real distance between two points that are 5 cm apart?

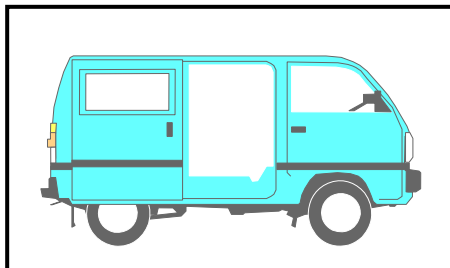
Answer:

3. The two trees are 50 km apart in real life. How far apart would they be in a drawing with a scale of 1: 500?

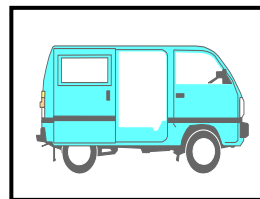


Answer:

Refer to the figures shown below and answer Question 4.



Real car  
930 cm long

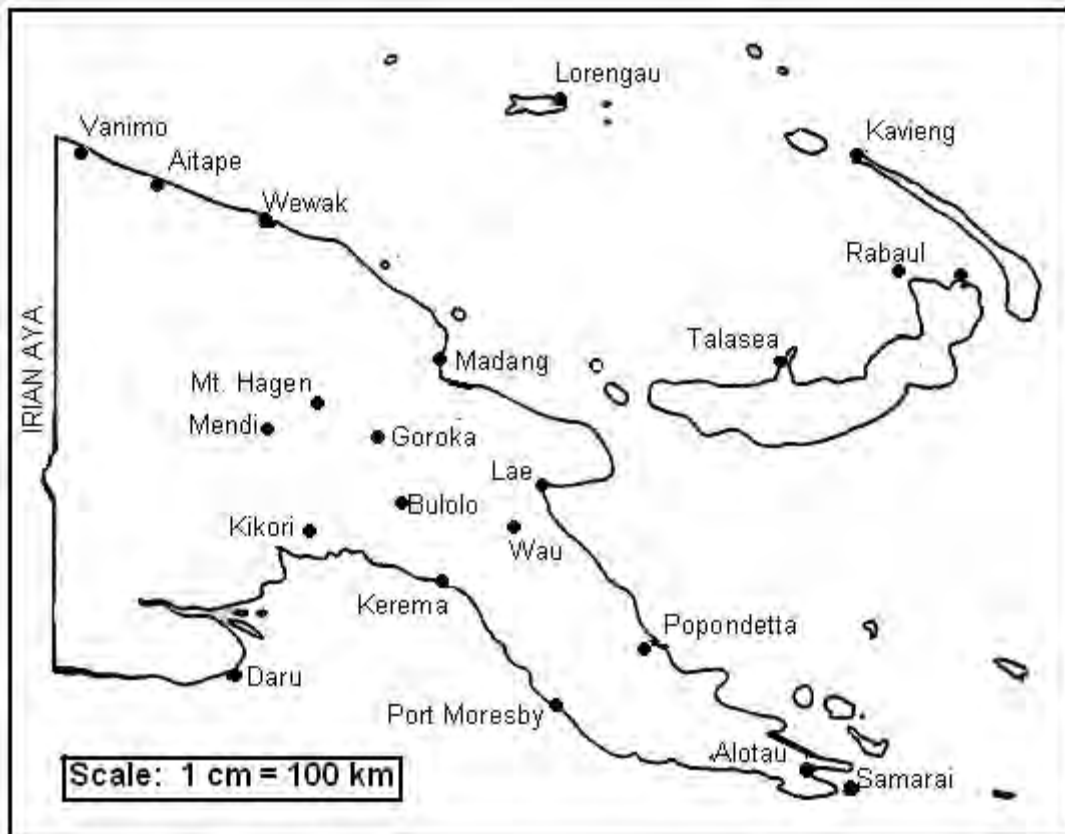


Drawn car  
9.3 mm long

4. What scale for length was used to draw the car?

Answer:

Refer to the map below to answer Questions 5 and 6.



5. What is the actual distance between Goroka and Port Moresby?

Distance on the map from Goroka to Port Moresby = \_\_\_\_\_ cm

Scale for length is 1 cm = \_\_\_\_\_ km

$$\begin{aligned} \text{So, } \underline{\hspace{2cm}} &= \underline{\hspace{1cm}} \times \underline{\hspace{1cm}} \text{ km} \\ &= \underline{\hspace{2cm}} \text{ km} \end{aligned}$$

The distance between Goroka and Port Moresby is \_\_\_\_\_ km.

6. What is the actual distance between Popondetta and Wewak?

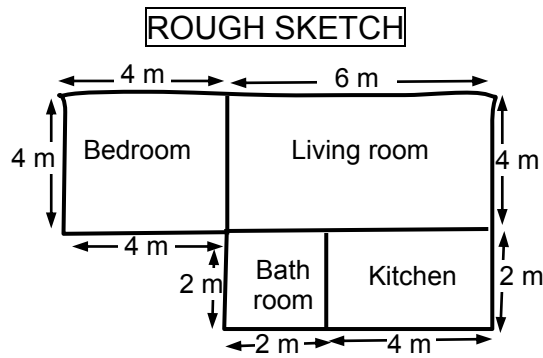
Distance on the map from Popondetta to Wewak = \_\_\_\_\_ cm

Scale for length is 1 cm = \_\_\_\_\_ km

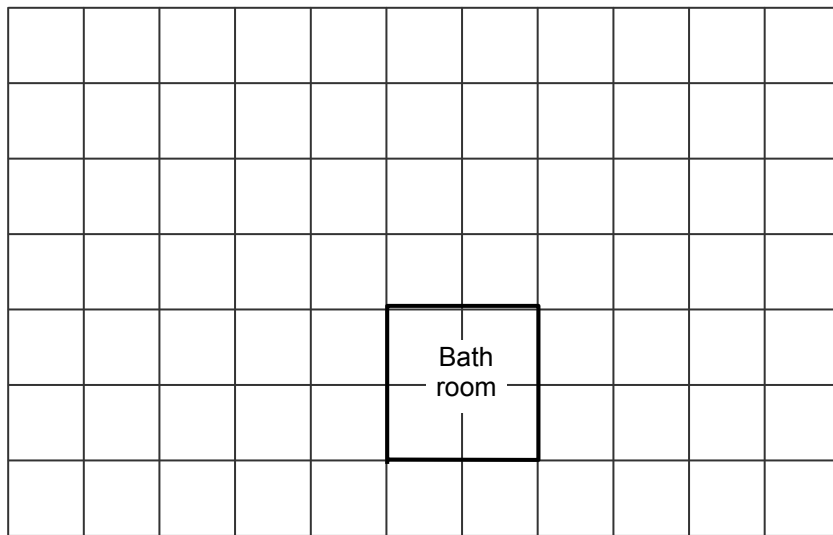
$$\begin{aligned} \text{So, } \underline{\hspace{2cm}} &= \underline{\hspace{1cm}} \times \underline{\hspace{1cm}} \text{ km} \\ &= \underline{\hspace{2cm}} \text{ km} \end{aligned}$$

The distance between Popondetta and Wewak is \_\_\_\_\_ km.

7. Here is a rough sketch of a shape of a house. There are four rooms in it. Use the grid below to draw a plan of the house using a scale of 1 cm = 1 m. The bathroom has been done for you.



**PLAN**




---

**CORRECT YOUR WORK. ANSWERS ARE AT THE END OF SUB-STRAND 3.**

**SUB-STRAND 3: SUMMARY**

---



*In this summary you will find some of the important ideas and terms to remember.*

- Similar means having the same shape, but different size.
- Two figures are similar when one figure can be enlarged and superimposed (put, lay or stacked one on top of the other) so that they coincide (on the same position) exactly.
- Similar figures are figures that have the same shape, but different sizes.
- Corresponding means matching.
- Corresponding angles and sides of similar shapes are pairs of matching angles and sides that are in the same position in the shapes.
- The corresponding angles in similar shapes are equal.
- The corresponding sides in similar shapes are usually not equal.
- In similar triangles the corresponding sides are opposite the equal angles.
- Enlargement is the result we get when we make an object or a shape bigger.
- Reduction is the result we get when we make an object or a shape smaller.
- Centre of enlargement is a point which can be used to draw similar shapes.
- Scale drawings have the same shapes as the objects they represent but they are of different sizes.
- A scale drawing is a drawing that shows a real object with accurate sizes except they have all been reduced or enlarged by a certain amount called the SCALE.
- The scale is the ratio of drawing length to corresponding real length.  
$$\text{Scale} = \text{length on drawing} : \text{real length}$$
- A scale is written by:
  1. writing corresponding measurement: 1 cm to 1 m
  2. using a simplified ratio; 1 : 100
  3. using a key number line, drawn to scale:
- Maps, plans or models match the shapes of the object they represent, but are enlarged or reduced in size. They are drawn to scale, in proportion (similar) to their originals.

---

**REVISE LESSONS 13-18 THEN DO SUB-STRAND TEST 3 IN ASSIGNMENT 2.**

## ANSWERS TO PRACTICE EXERCISES 13 – 18

---

### Practice Exercise 13

2. d                      3. a                      4. b                      5. b
- 

### Practice Exercise 14

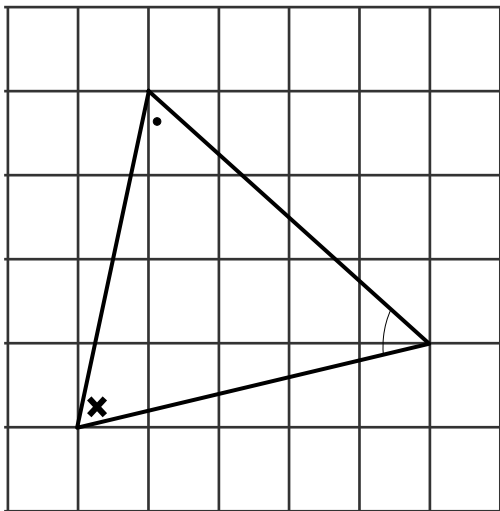
1. a)  $\angle O$  corresponds to  $\angle A$   
 $\angle Y$  corresponds to  $\angle R$
- b)  $\angle D$  corresponds to  $\angle G$   
 $\angle B$  corresponds to  $\angle F$   
 $\angle C$  corresponds to  $\angle H$
- c)  $\angle M$  corresponds to  $\angle P$   
 $\angle N$  corresponds to  $\angle Q$   
 $\angle O$  corresponds to  $\angle R$
2.    Size of angles in  $\triangle ABC$       Size of angles in  $\triangle XYZ$       Size of angles in  $\triangle RST$
- |                        |                        |                        |
|------------------------|------------------------|------------------------|
| $\angle A = 40^\circ$  | $\angle X = 40^\circ$  | $\angle R = 40^\circ$  |
| $\angle B = 100^\circ$ | $\angle Y = 104^\circ$ | $\angle S = 100^\circ$ |
| $\angle C = 40^\circ$  | $\angle Z = 36^\circ$  | $\angle T = 40^\circ$  |
- $\triangle ABC$  is similar to  $\triangle RST$  because  $\angle A = \angle R$   
 $\angle B = \angle S$   
 $\angle C = \angle T$
3. b)  $\overline{DM}$  corresponds to  $\overline{HE}$   
 $\overline{MC}$  corresponds to  $\overline{ER}$   
 $\overline{DC}$  corresponds to  $\overline{HR}$
- c)  $\overline{UV}$  corresponds to  $\overline{OP}$   
 $\overline{VT}$  corresponds to  $\overline{PM}$   
 $\overline{TU}$  corresponds to  $\overline{MO}$
4. a) Quadrilaterals  $KLMN$  and  $QRST$
- b) 1.  $\angle K = \angle Q$   
2.  $\angle L = \angle R$   
3.  $\angle M = \angle S$   
4.  $\angle N = \angle T$
- c) 1.  $\overline{KL}$  corresponds to  $\overline{QR}$   
2.  $\overline{LM}$  corresponds to  $\overline{RS}$   
3.  $\overline{MN}$  corresponds to  $\overline{ST}$   
4.  $\overline{KN}$  corresponds to  $\overline{QT}$



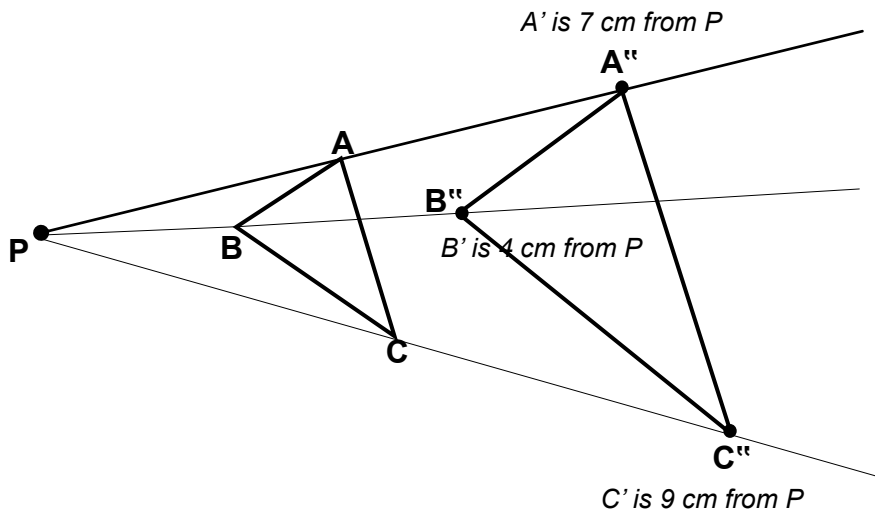
**Practice Exercise 15**

1. b)  $\angle J$  corresponds to  $\angle B$       YES  
 $\angle E$  corresponds to  $\angle A$   
 $\angle T$  corresponds to  $\angle G$
- c)  $\angle U$  corresponds to  $\angle Z$       YES  
 $\angle V$  corresponds to  $\angle Y$   
 $\angle W$  corresponds to  $\angle X$
2. b)  $\angle N = \angle D$  ;  $\overline{BE}$  corresponds to  $\overline{RO}$   
 $\angle E = \angle O$  ;  $\overline{BN}$  corresponds to  $\overline{RD}$   
 $\angle B = \angle R$  ;  $\overline{EN}$  corresponds to  $\overline{OD}$
- c)  $\angle O = \angle D$  ;  $\overline{SP}$  corresponds to  $\overline{FE}$   
 $\angle S = \angle F$  ;  $\overline{OP}$  corresponds to  $\overline{DE}$   
 $\angle P = \angle E$  ;  $\overline{SO}$  corresponds to  $\overline{FD}$
3. b)  $\angle T = \angle N$  ;  $\overline{TQ}$  corresponds to  $\overline{NK}$   
 $\angle S = \angle M$  ;  $\overline{QR}$  corresponds to  $\overline{KL}$   
 $\angle Q = \angle K$  ;  $\overline{RS}$  corresponds to  $\overline{LM}$   
 $\angle R = \angle L$  ;  $\overline{ST}$  corresponds to  $\overline{MN}$
- c)  $\angle K = \angle H$  ;  $\overline{KL}$  corresponds to  $\overline{HE}$   
 $\angle N = \angle G$  ;  $\overline{LM}$  corresponds to  $\overline{EF}$   
 $\angle M = \angle F$  ;  $\overline{MN}$  corresponds to  $\overline{FG}$   
 $\angle L = \angle E$  ;  $\overline{NK}$  corresponds to  $\overline{GH}$

**Practice Exercise 16**

1. a)  b) yes      c) enlargement

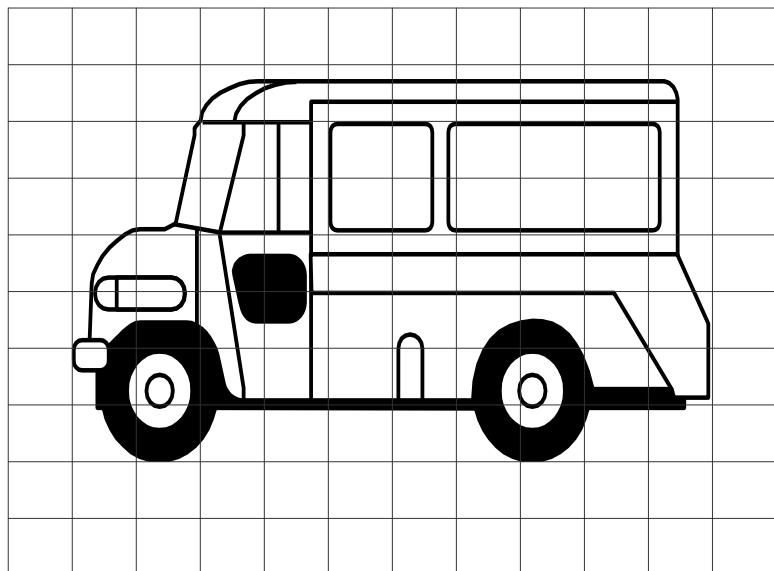
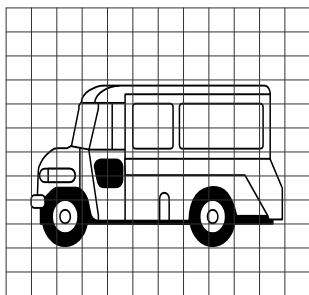
2.



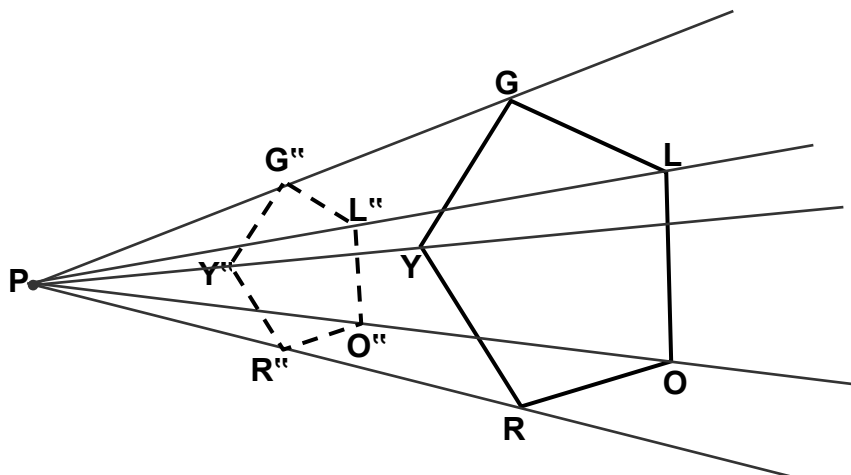
Yes, 3 pairs of corresponding angles are equal.  
 Yes, the triangles are similar.

**Practice Exercise 17**

1.



2.



PG is 7 cm, so PG'' must be 3.5 cm (half of 7 cm)

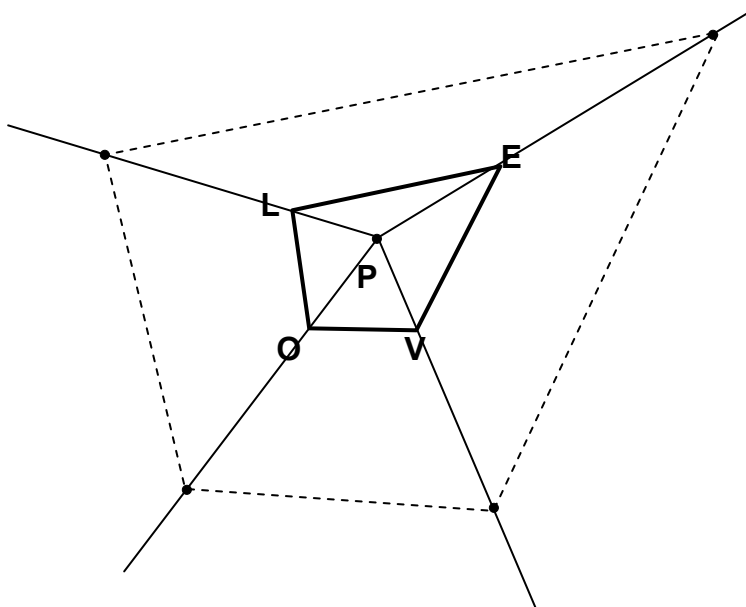
PL is 8.5 cm, so PL'' must be 4.25 cm (half of 8.5 cm)

PO is 8.5 cm, so PO'' must be 4.25 cm (half of 8.5 cm)

PR is 6.5 cm, so PR'' must be 3.25 cm (half of 6.5 cm)

PY is 5 cm, so PY'' must be 2.25 cm (half of 5 cm)

3.



PL is 1 cm, so PL'' is 3 cm (3 x 1 cm)

PO is 1.5 cm, so PO'' is 4.5 cm (3 x 1.5 cm)

PV is 1.3 cm, so PV'' is 3.9 cm (3 x 1.3 cm)

PE is 2 cm, so PE'' is 6 cm (3 x 2 cm)

### Practice Exercise 18

1. a) 1:100      b) 1:1000      c) 1:1000

2. 5 m

3. 10 m

4. 1:100

5. Distance on the map from Goroka to Port Moresby = 4.3 cm

Scale for length is 1 cm = 100 km

So, 4.3 cm = 4.3 x 100 km

= 430 km

The distance between Goroka and Port Moresby is 430 km.

6. Distance on the map from Popondetta to Wewak = 7.5 cm

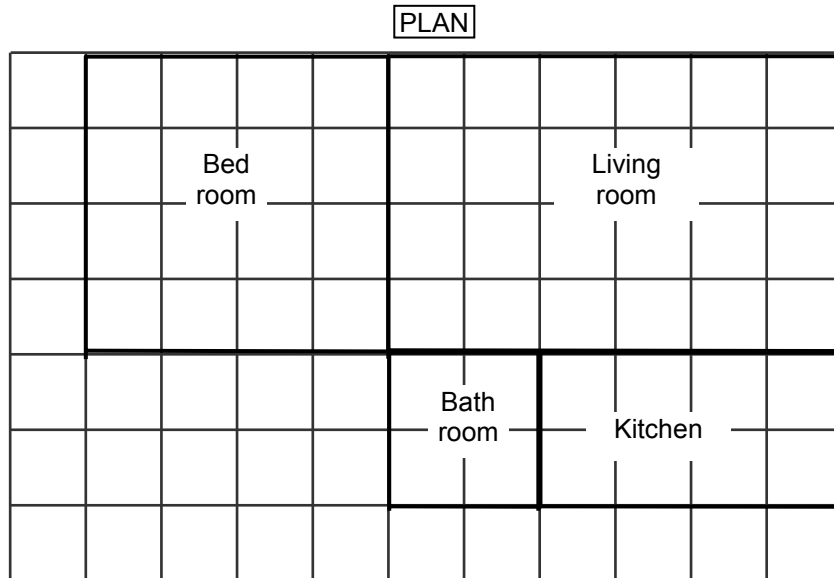
Scale for length is 1 cm = 100 km

$$\text{So, } \underline{7.5} \text{ cm} = \underline{7.5} \times \underline{100} \text{ km}$$

$$= \underline{750} \text{ km}$$

The distance between Popondetta and Wewak is 750 km

7.



**END OF SUB-STRAND 3**



## **SUB-STRAND 4**

### **TESSELLATIONS**

**Lesson 19: Plane Shapes and Patterns**

**Lesson 20: Translation**

**Lesson 21: Rotation**

**Lesson 22: Symmetry**

**Lesson 23: Line Symmetry**

**Lesson 24: Rotational Symmetry**

## SUB-STRAND 4: TESSELLATION

---

### Introduction

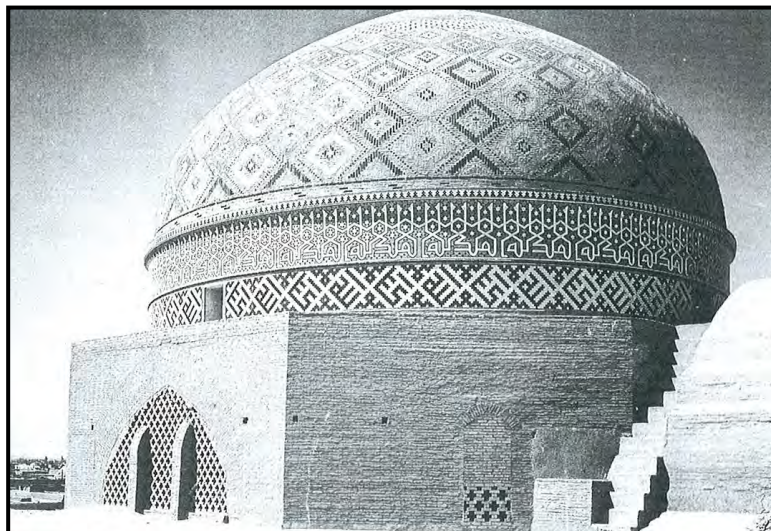


This is Sub-strand 4 of your Grade 8 Mathematics Strand 2. In this Sub-strand, you will extend further your knowledge of the concepts and ideas of Tessellation.

In your Grade 7 Mathematics Strand 2 Sub-strand 4 introduction, Tessellation is defined as a pattern made of identical shapes that fit together without any gaps or overlaps.

Tessellation and shapes are appreciated and applied in many cultural backgrounds such as the tiles of Islamic Mosques to the traditional tattoo patterns of Papua New Guinea.

Look at the picture below.



In this sub-strand you will investigate rotational symmetry, create tessellations that have rotational symmetry and identify traditional and modern patterns in handicrafts with rotational symmetry.

## Lesson 19: Plane Shapes and Patterns



We looked at similar shapes and scale readings in the previous lesson.



In this lesson, you will:

- define tessellation
- determine which shapes tessellate exactly at a point
- determine which combination of shapes will tessellate by considering their angle size.

We can see plane shapes and patterns applied in many infrastructures in our surroundings. For example, the extensive use of tiles to cover and decorate walls, floors and ceilings of houses and buildings, and even sidewalks, paths and porches, with geometric designs and patterns. These small tiles are called **tessellae**. Tessellations are seen throughout art history, from ancient architecture to modern art.

What is a tessellation?

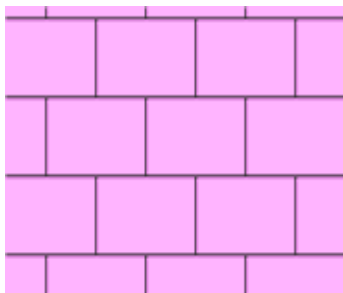


We usually associate tessellations with tiling or filling of a two-dimensional space.

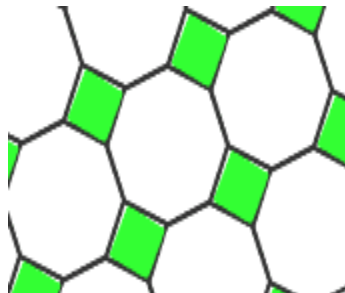
**Two-dimensional space** refers to **shapes with two dimensions** such as planes or surfaces.

**A tessellation is created when a shape is repeated over and over again. All the figures fit onto a flat surface exactly without any gaps or overlaps. Another word for tessellation is *tiling*.**

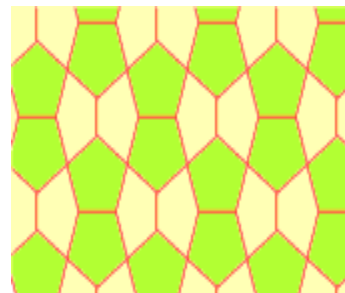
The designs below are practical examples of a tessellation created by filling a space with shapes repeatedly over and over again without gaps or overlaps.



Rectangles



Octagons and Squares



Different Pentagons

On the next page, we will look at the types of tessellations.





First we will look at Tessellations created by regular polygons.

**A regular polygon is a polygon that has 3, 4, 5 or more sides and angles, which are all equal.**

Remember:

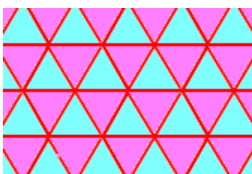
*Regular* means that the sides and angles of the polygon are all equivalent (i.e., the polygon is both equiangular and equilateral). *Congruent* means that the polygons that you put together are all the same size and shape and contains all the same features.

**A regular tessellation is a tessellation which is made up of congruent regular polygons.**

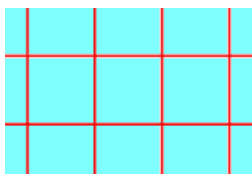
There are only 3 regular polygons that tessellate in a plane. These are the triangles, the squares and the hexagons.

Here are examples.

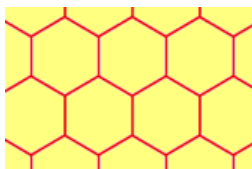
1. A tessellation of triangles



2. A tessellation of squares



3. A tessellation of hexagons



Looking at these three examples you can easily notice that the squares are lined up with each other while the triangles and hexagons are not. Also, if you look at 6 triangles at a time, they form a hexagon, so the tiling of triangles and the tiling of hexagons are similar and they cannot be formed by directly lining shapes up under each other - a slide (or a glide!) is involved.

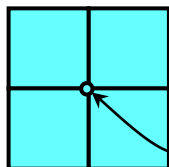
You can work out the interior measure of the angles for each of these polygons:

Shape	Angle Measure in Degrees
triangle	60
square	90
pentagon	108
hexagon	120
more than six sides	more than 120 degrees

Since the regular polygons in a tessellation must fill the plane at each **vertex**, the interior angle must be an exact divisor of 360 degrees. This works for the triangle, square, and hexagon, and you can show working tessellations for these figures. For all the others, the interior angles are not exact divisors of 360 degrees, and therefore those figures cannot tile the plane.



What is a vertex?



A vertex is where all the "corners" meet!



### Example 1

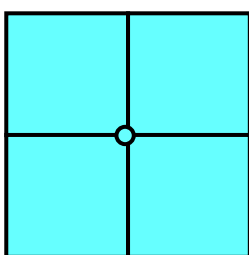
A tessellation of squares is named "**4.4.4.4**".

Here's how:

1. Choose a vertex, and then look at one of the polygons that touch that vertex.  
How many sides does it have?  
Since it's a square, it has four sides, and that's where the first "4" comes from.
2. Now keep going around the vertex in either direction, finding the number of sides of the polygons until you get back to the polygon you started with. How many polygons did you count?

There are four polygons, and each has four sides.  
The interior angle of each square is 90.

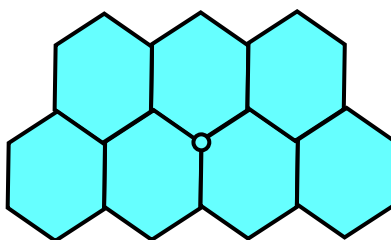
$$90 + 90 + 90 + 90 = 360 \text{ degrees}$$



**4.4.4.4**

### Example 2

For a tessellation of regular congruent hexagons, if you choose a vertex and count the sides of the polygons that touch it, you'll see that there are three polygons and each has six sides, so this tessellation is called "**6.6.6**": The interior angle of each hexagon is 120 degrees.

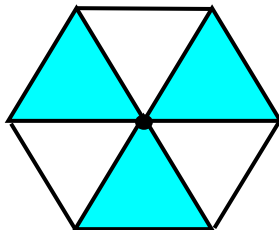


**6.6.6**

$$120 + 120 + 120 = 360 \text{ degrees}$$

## Example 3

A tessellation of triangles has six polygons surrounding a vertex, and each of them has three sides: "3.3.3.3.3.3". The interior angle of each equilateral triangle is 60 degrees.



**3.3.3.3.3.3**

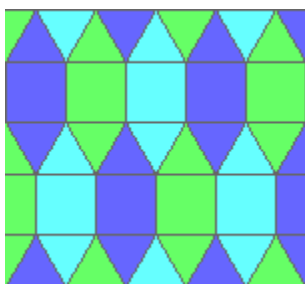
$$60 + 60 + 60 + 60 + 60 + 60 = 360 \text{ degrees}$$

**For a regular tessellation, the pattern is identical at each vertex.**

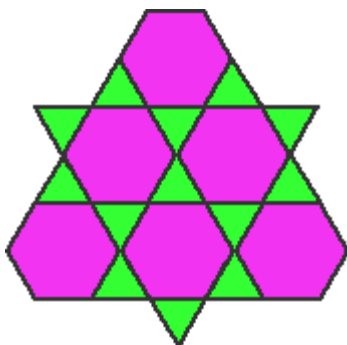


We can also make a tessellation using a variety of regular polygons.

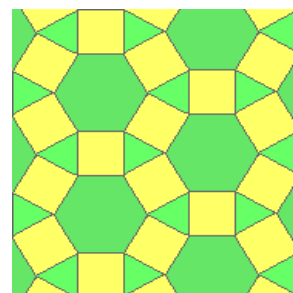
## Examples



Squares and triangles



Hexagons and triangles



hexagons, squares, triangles

These tessellation patterns above are all examples of **semi-regular tessellations**.

**A semi-regular tessellation is made by using two or more different regular polygons. The pattern at each vertex must be the same!**

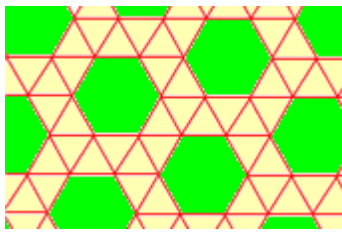
A semi-regular tessellation has two properties which are:

1. It is formed by regular polygons.
2. The arrangement of polygons at every vertex point is identical.

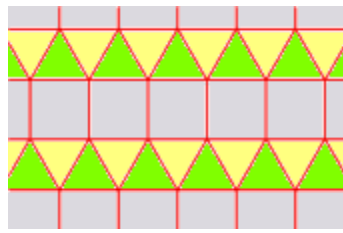
The rules in creating regular tessellations are also applied in creating semi-regular tessellations. Every vertex must have the same configuration or identical.

There are only eight semi-regular tessellations. See next page.

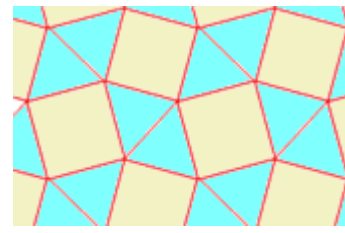
Here are the eight Semi-regular Tessellations.



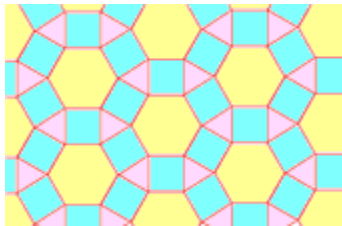
3.3.3.3.6



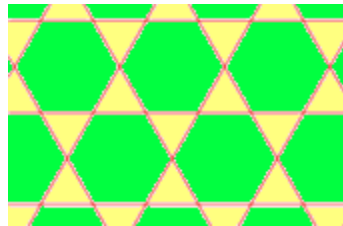
3.3.3.4



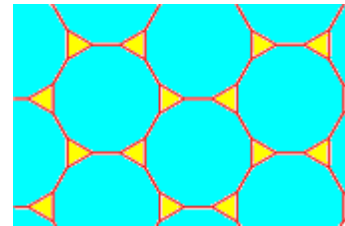
3.3.4.3.4



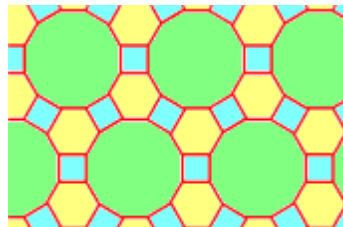
3.4.6.4



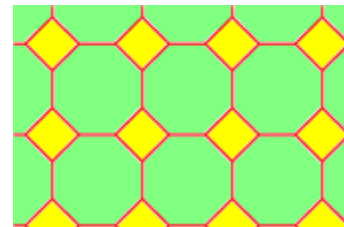
3.6.3.6



3.12.12



4.6.12

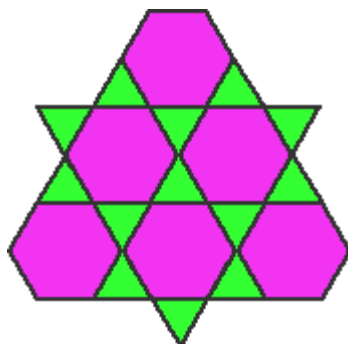


4.8.8

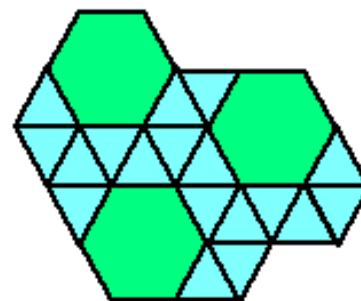
To name a tessellation, simply work your way around one vertex counting the number of sides of the polygons that form that vertex. The trick is to go around the vertex in order so that the smallest numbers possible appear first.

Look at the examples below.

These tessellations are both made up of hexagons and triangles, but their vertex configuration is different. That's why we've named them!



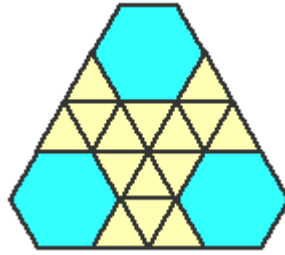
3.6.3.6



3.3.3.3.6

That's why we wouldn't call our 3, 3, 3, 3, 6 tessellation a 3, 3, 6, 3, 3!

Here's another tessellation made up of hexagons and triangles.



This is not an official semi-regular tessellation because it breaks the rule or pattern at each vertex.

---

**NOW DO PRACTICE EXERCISE 19**



## Practice Exercise 19

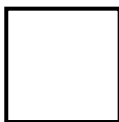
- Using Grid paper, draw your own tessellation using the following steps. You need to start by drawing a perfect square. There are two methods that will give you a perfect square:

- 1) Use a piece of tracing paper, laid over graph paper

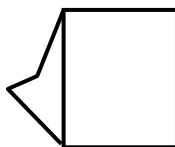
- 2) Use the upper and lower edges of a ruler to draw parallel lines, and your protractor to get a 90 degree angle

Then follow the steps below:

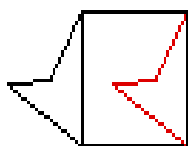
- Create a square.



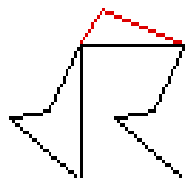
- Draw a simple shape on one side of the square.



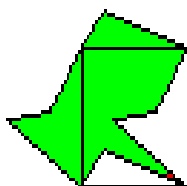
- Trace the shape on a piece of tracing paper and slide it to the opposite side of the square.



- Draw a simple shape on the top of the square



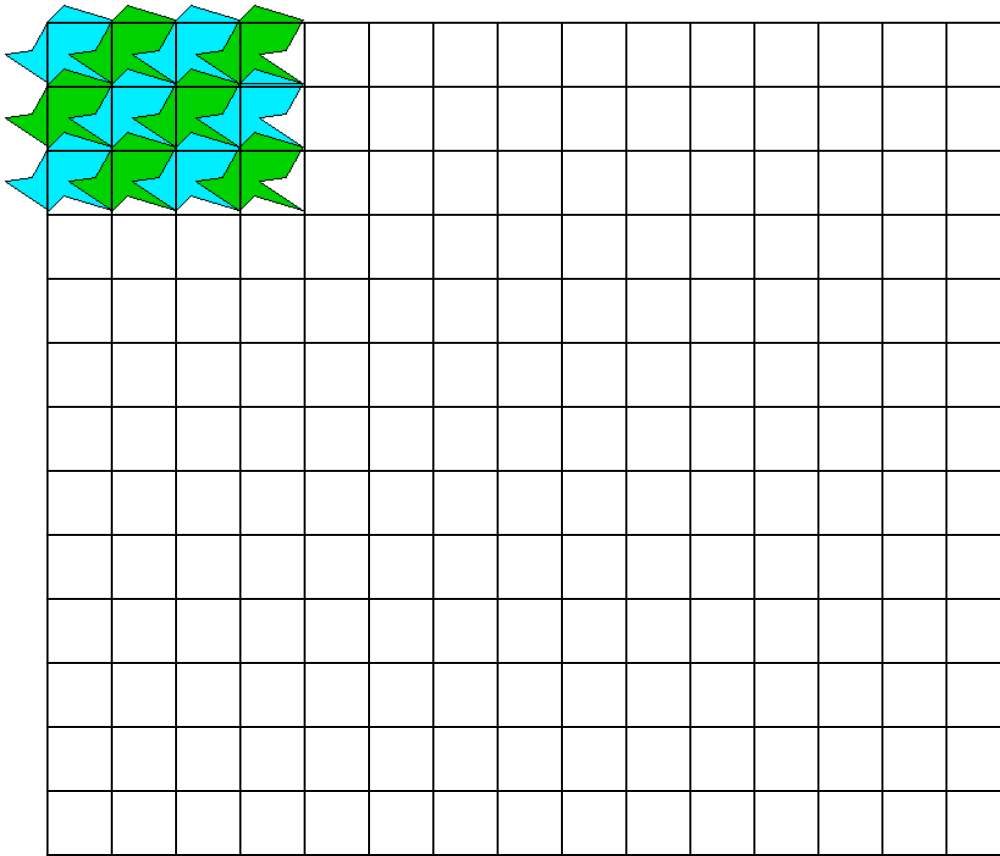
- Trace the shape on a piece of tracing paper and slide it to the opposite side of the square.



6. Trace the whole figure and translate it horizontally. Notice that the shapes interlock perfectly.



7. Continue to trace the entire figure, and translate the tracings horizontally and vertically to create a tessellation as large as you like. Don't trace the square. Now you can decorate and color your tessellation!



---

**NOW GO TO THE NEXT LESSON ON THE NEXT PAGE.**

## Lesson 20: Translation



We looked at Tessellations in the last lesson.

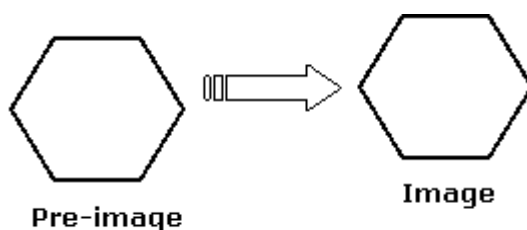


In this lesson, you will:

- define a translation
- make the translation of objects or shapes at a given distance and direction on a dot or grid paper.

Have you tried copying objects where the copy holds some properties? Think of when you copy/paste a picture on your computer.

Example



The original figure is called the **pre-image**; the new (copied) picture is called the **image** of the transformation.

Let us look at the most basic transformation called Translation.

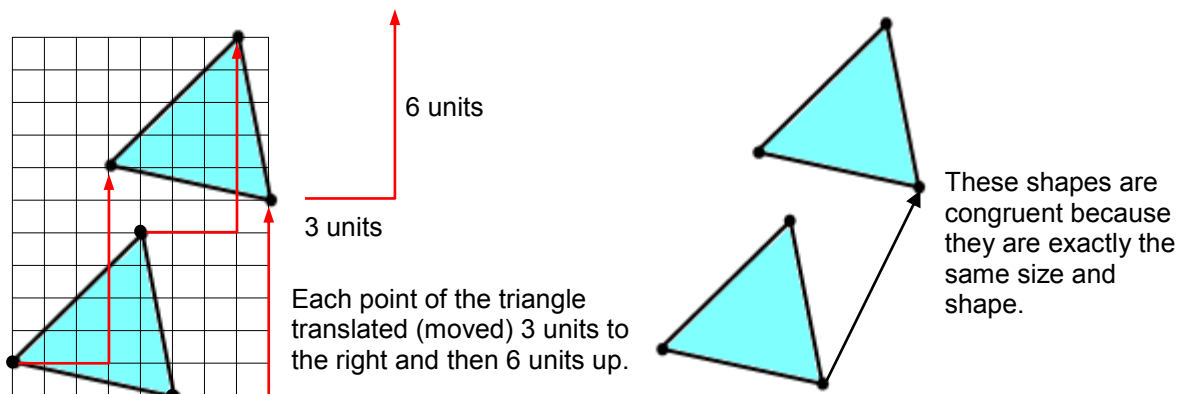
*What is a translation?*



**Translation simply means a “shift” or moving the shape without turning or reflection and the object stays the same size.**

Translation occurs when you move a shape from one position to another by sliding without turning, rotating, resizing or anything else, just moving.

Translations are usually shown on a square grid. Look at the example below.



Each translation follows a rule. In this case, the rule is "3 to the right and 6 up."



Here is another example.

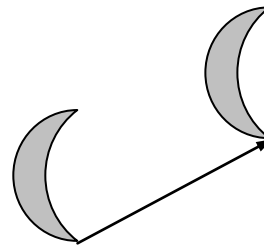
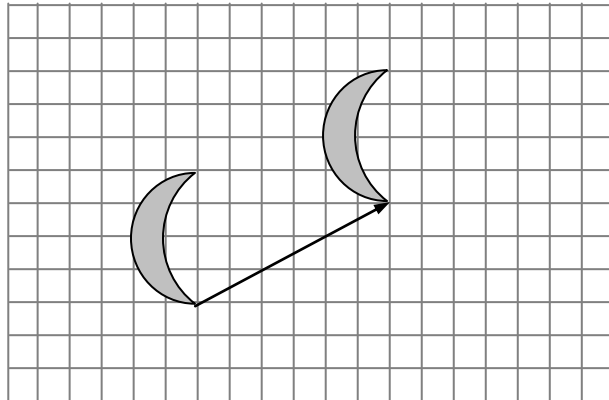
The translation of the moon shape is 6 squares to the right and 3 squares upward.

Translations are often written in a vertical bracket like this:  $\begin{pmatrix} +6 \\ +3 \end{pmatrix}$

The horizontal movement is always written at the top of the bracket.

The Plus signs (+) indicate or show that the movement is to the **right** or **up**.

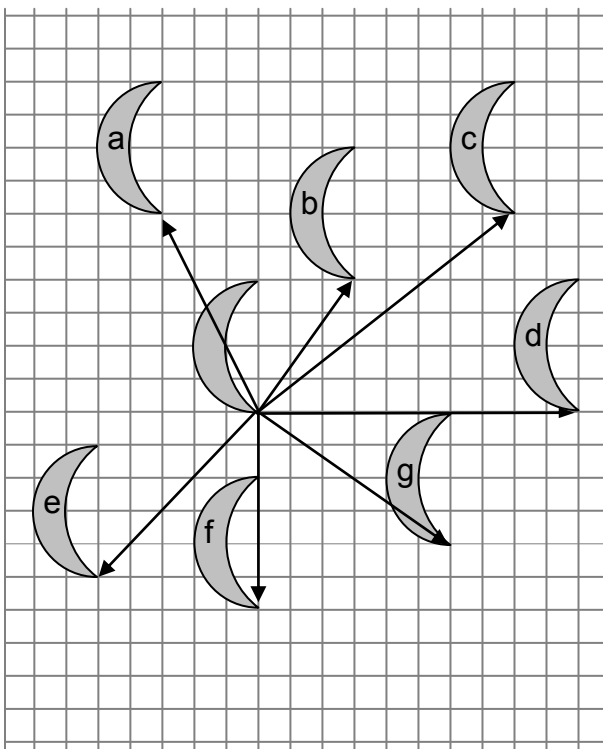
The Minus signs (-) indicate or show that the movement is to the **left** or **down**.



These shapes are congruent because they are exactly the same size and shape.

You can also translate a pre-image to the left, down or any combination of two of the four directions.

Here are some translations applied to the moon shape.



Moon shape **a**'s is  $\begin{pmatrix} -3 \\ +6 \end{pmatrix}$

Moon shape **b**'s is  $\begin{pmatrix} +3 \\ +4 \end{pmatrix}$

Moon shape **c**'s is  $\begin{pmatrix} +8 \\ +6 \end{pmatrix}$

Moon shape **d**'s is  $\begin{pmatrix} +10 \\ 0 \end{pmatrix}$

Moon shape **e**'s is  $\begin{pmatrix} -5 \\ -5 \end{pmatrix}$

Moon shape **f**'s is  $\begin{pmatrix} 0 \\ -6 \end{pmatrix}$

Moon shape **g**'s is  $\begin{pmatrix} +6 \\ -4 \end{pmatrix}$

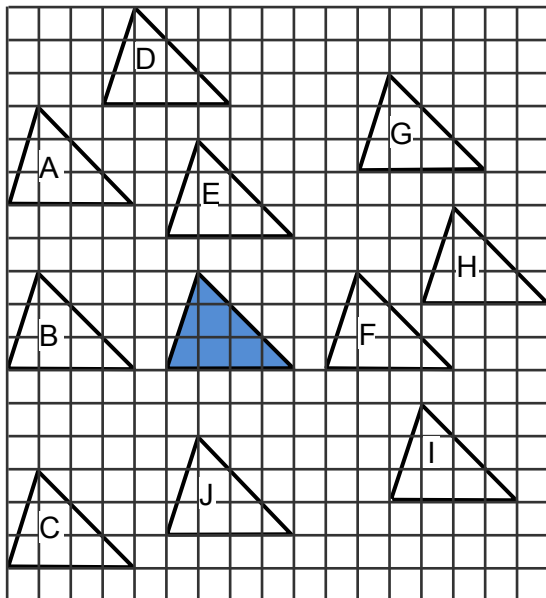
**Note:** All these shapes are congruent because they are exactly the same shape and size.

**NOW DO PRACTICE EXERCISE 20**



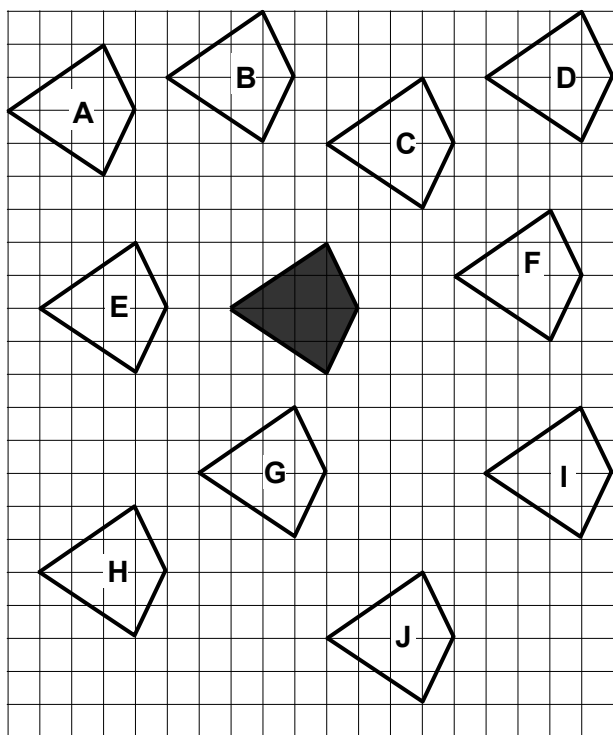
### Practice Exercise 20

1. Using vertical brackets write down the translations which move the shaded triangle to each ten new positions as shown on the diagram below.



- Triangle A \_\_\_\_\_
- Triangle B \_\_\_\_\_
- Triangle C \_\_\_\_\_
- Triangle D \_\_\_\_\_
- Triangle E \_\_\_\_\_
- Triangle F \_\_\_\_\_
- Triangle G \_\_\_\_\_
- Triangle H \_\_\_\_\_
- Triangle I \_\_\_\_\_
- Triangle J \_\_\_\_\_

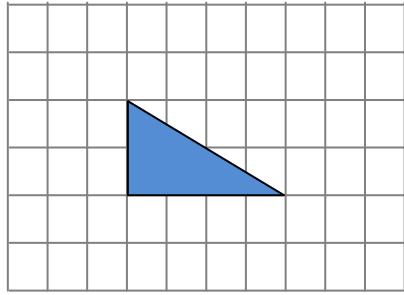
2. The diagram below shows a shaded kite moved to ten new positions.



- Kite A \_\_\_\_\_
- Kite B \_\_\_\_\_
- Kite C \_\_\_\_\_
- Kite D \_\_\_\_\_
- Kite E \_\_\_\_\_
- Kite F \_\_\_\_\_
- Kite G \_\_\_\_\_
- Kite H \_\_\_\_\_
- Kite I \_\_\_\_\_
- Kite J \_\_\_\_\_

Use vertical brackets to write down the translation which move the shaded kite to each new position.

3. Copy this triangle onto the squared grid paper below.



Show the new position of the triangle after each of the following translations.

a.  $\begin{pmatrix} 0 \\ -4 \end{pmatrix}$

b.  $\begin{pmatrix} 0 \\ +4 \end{pmatrix}$

c.  $\begin{pmatrix} -6 \\ 0 \end{pmatrix}$

d.  $\begin{pmatrix} +6 \\ 0 \end{pmatrix}$

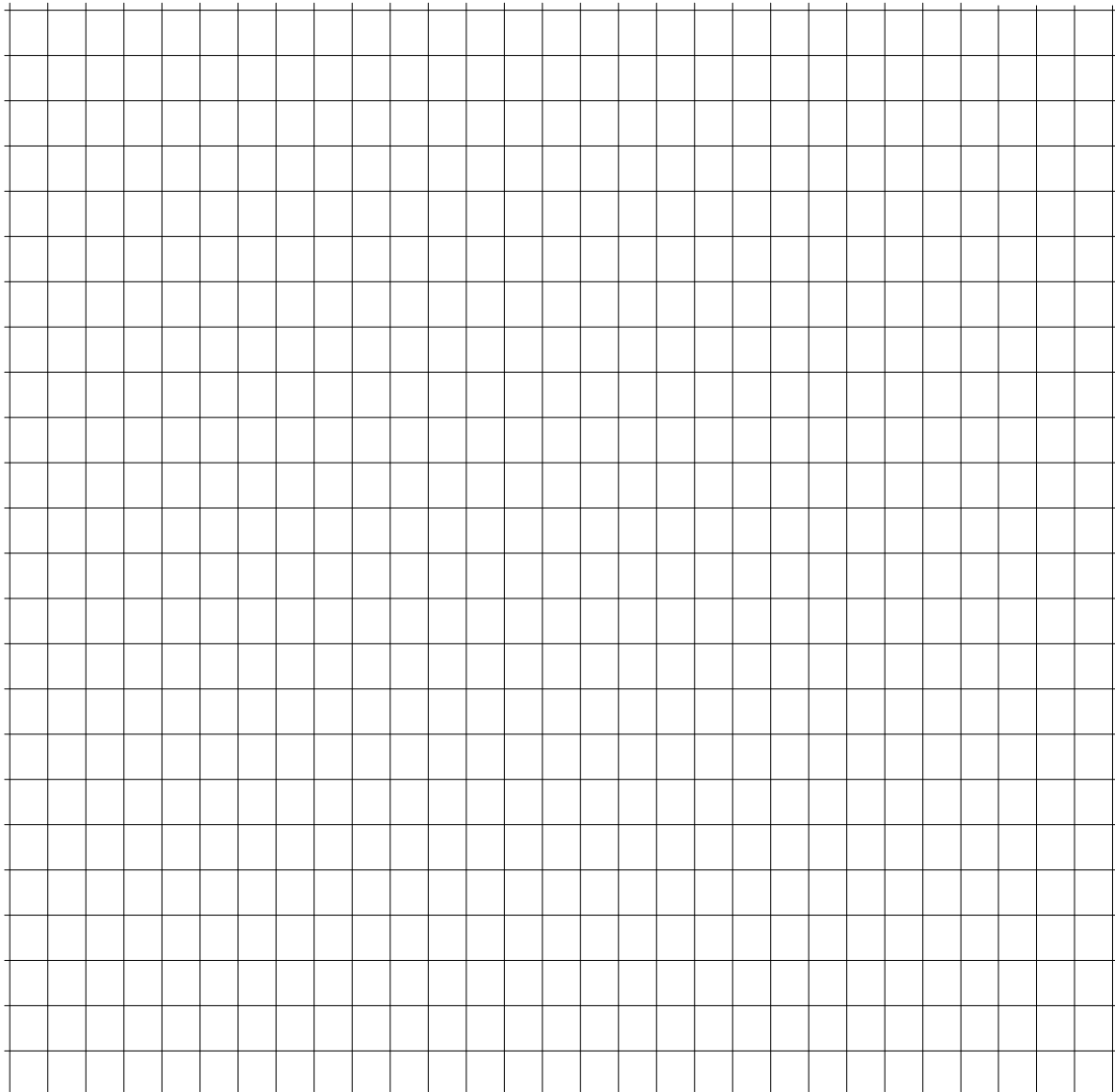
e.  $\begin{pmatrix} -6 \\ -4 \end{pmatrix}$

f.  $\begin{pmatrix} +6 \\ -4 \end{pmatrix}$

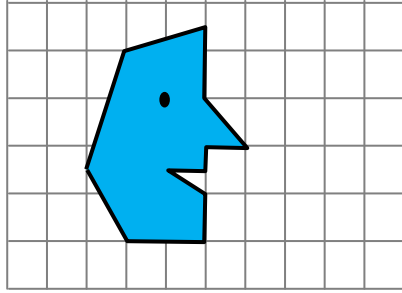
g.  $\begin{pmatrix} -6 \\ +4 \end{pmatrix}$

h.  $\begin{pmatrix} +6 \\ +4 \end{pmatrix}$

Answer:



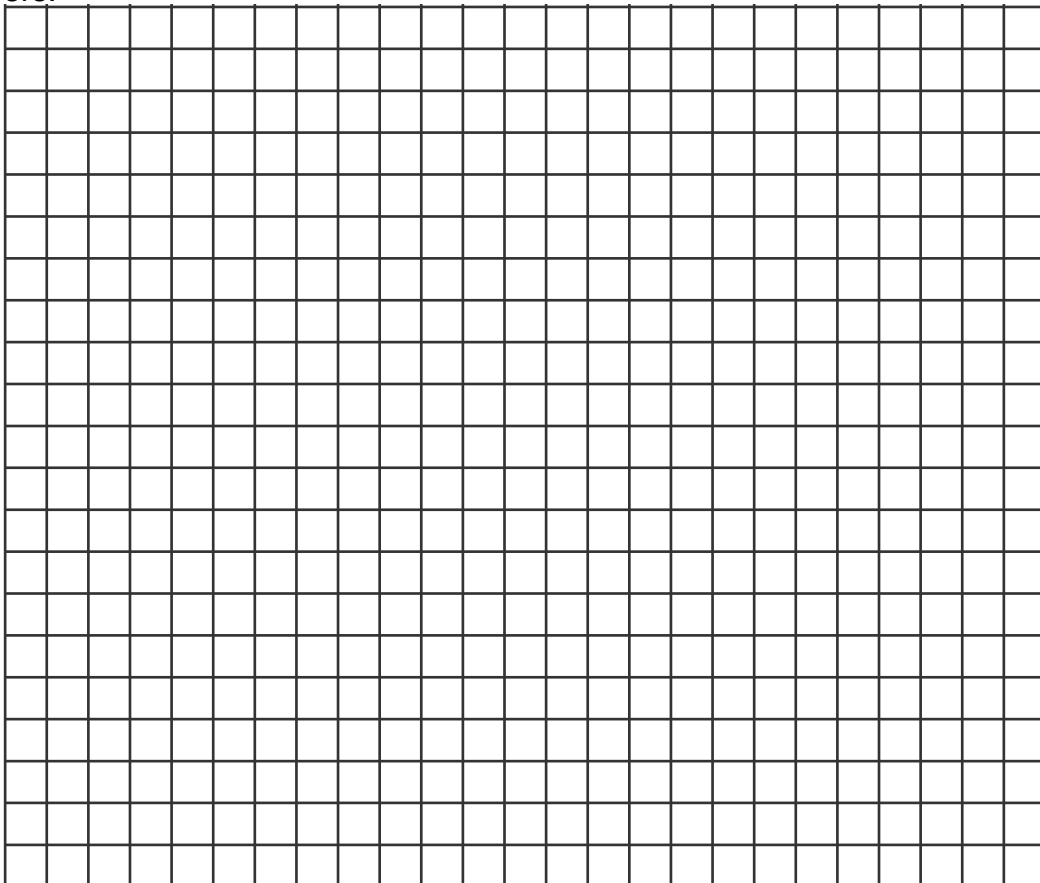
4. Copy this polygonal man onto the squared grid paper below.



Show the new position of the polygonal man after each of these translations.

- a.  $\begin{pmatrix} +5 \\ 0 \end{pmatrix}$       b.  $\begin{pmatrix} -5 \\ 0 \end{pmatrix}$       c.  $\begin{pmatrix} +7 \\ +7 \end{pmatrix}$       d.  $\begin{pmatrix} +8 \\ +7 \end{pmatrix}$
- e.  $\begin{pmatrix} 0 \\ +5 \end{pmatrix}$       f.  $\begin{pmatrix} 0 \\ -5 \end{pmatrix}$       g.  $\begin{pmatrix} -8 \\ -6 \end{pmatrix}$       h.  $\begin{pmatrix} +8 \\ -6 \end{pmatrix}$

Answers:



**CORRECT YOUR WORK. ANSWERS ARE AT THE END OF SUB-STRAND 4.**

## Lesson 21: Rotation



You have looked at translation of objects in the last lesson.



In this lesson, you will:

- define a rotation
- make rotations of objects or shapes at a given angle and direction.

You have already considered the effect of the translation of objects and shapes. Objects and shapes are said to be transformed by translation, which happens when a shape is moved up, down, left or right.

Now we will look at another example of a transformation called “rotation”.



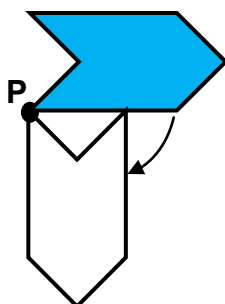
What is a rotation?

**Rotation came from the word “rotate” which means “to move in a circle round a central point”.**



Rotation moves a shape or object by turning it. When a shape or an object is rotated, it moves around a central point called the “centre of rotation” through a certain angle .

Take a look at the diagram below.



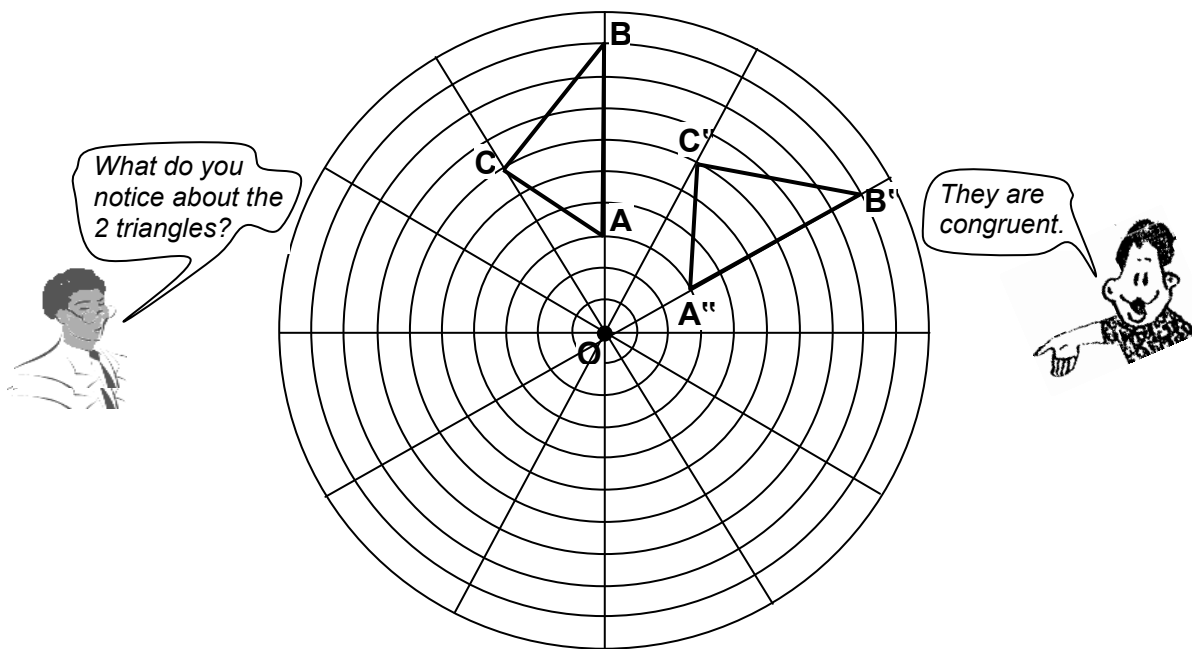
**Note:** If you rotate a shape, it is still congruent to the original shape.

This rotation is a  $90^\circ$  clockwise rotation about the point **P**. The point **P** is called the **centre of rotation**.

The angle between the original position of a shape and its new position is called the **angle of rotation**.

Take a good look at FIGURE 20.1 on the next page.

FIGURE 20.1

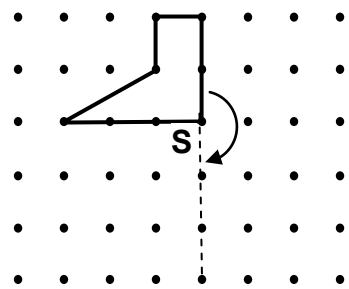


You will also note that the distance between the triangles and the centre of rotation which is **O** are the same and the angle of rotation through **O** is  $60^\circ$ .

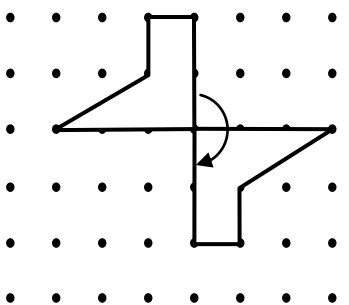
Now see the examples.

Example 1

The steps below show how to rotate a shape  $180^\circ$  clockwise.



**S** is the centre of rotation

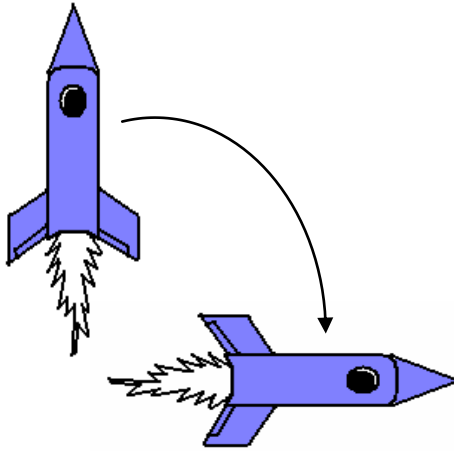


- Step 1 Copy the shape on to a dot or grid paper.
- Step 2 Trace the shape
- Step 3 Hold centre of rotation, **S** with a pin or the point of your compass.
- Step 4 Spin the tracing paper and draw the image as shown.

The shape has been rotated in a clockwise direction because it is the direction in which the hands of a clock moves. Anti-clockwise is the opposite direction.

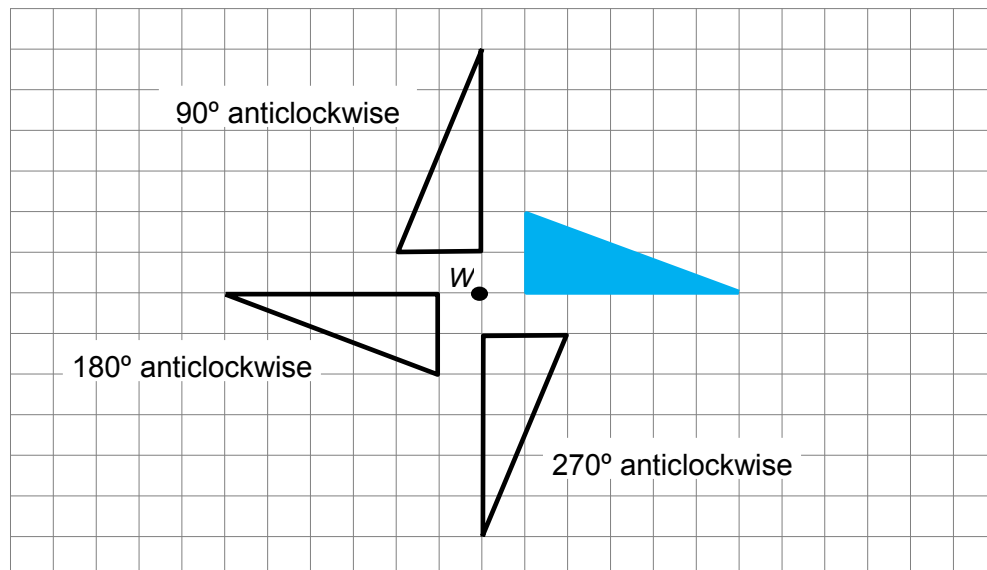
## Example 2

The shape below has been rotated  $90^\circ$  in a clockwise direction. They are congruent.



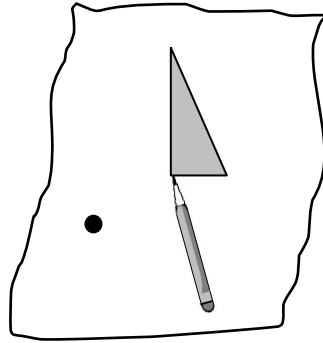
## Example 3

This diagram shows a shape rotated about a point  $X$  through anticlockwise angles of  $90^\circ$ ,  $180^\circ$  and  $270^\circ$ .

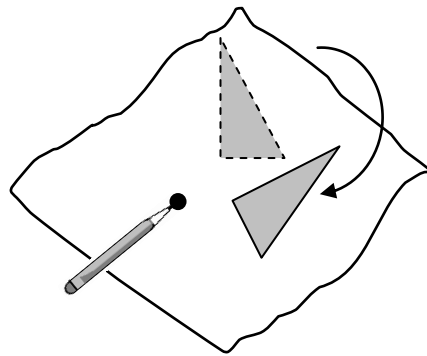


Rotations can be completed using tracing paper. This is done in three stages.

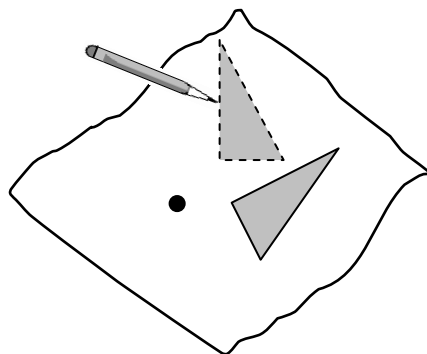
1. Cover the object and the centre of rotation with a tracing paper and trace.



2. Place the point on the centre of rotation and turn the tracing paper through the required angle.



3. Trace the object back onto the paper.



---

**NOW GO TO PRACTICE EXERCISE 21**

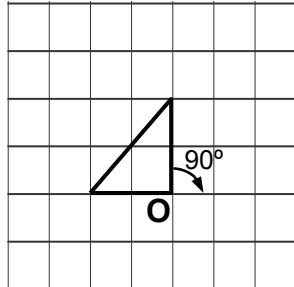




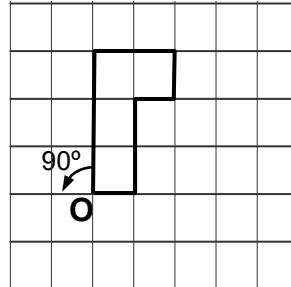
### Practice Exercise 21

1. Copy each diagram on squared grid paper and draw the given rotations.

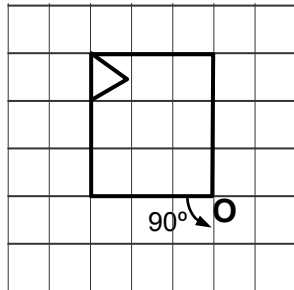
a.



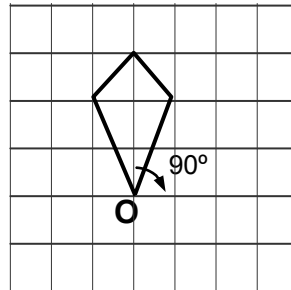
b.



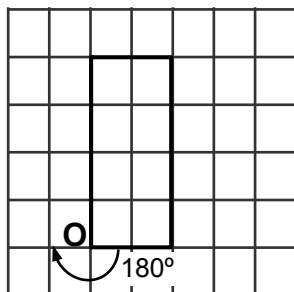
c.



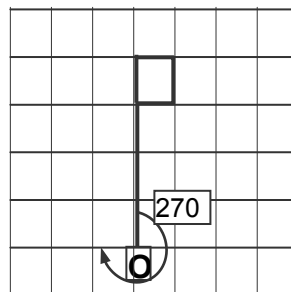
d.



e.



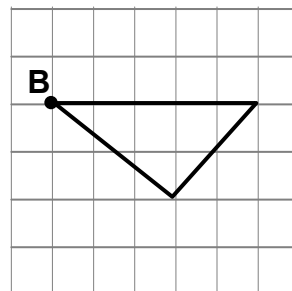
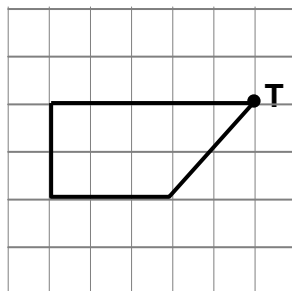
f.



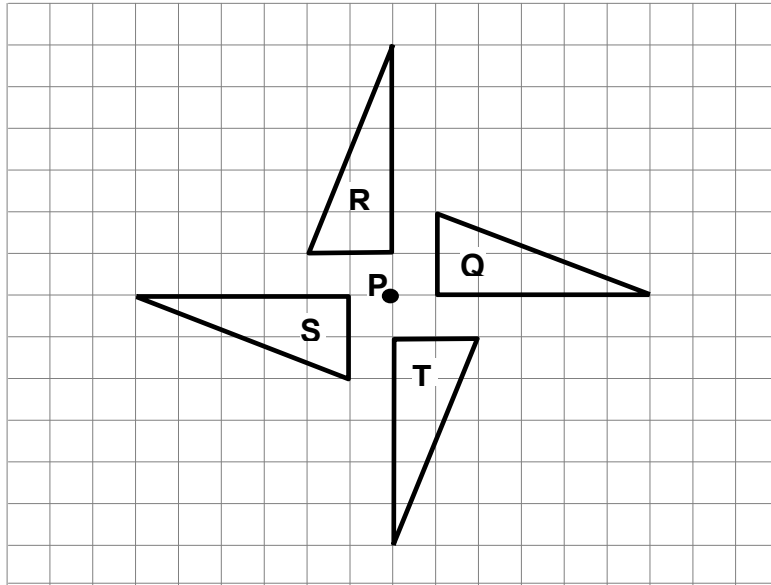
2. Copy each diagram onto a squared grid paper and use tracing paper to complete the given rotation.

a. 270° clockwise about T

b. 270°



3. Refer to the diagram and do what is asked below.



Write down the clockwise rotation about **P** which will move:

- |    |          |    |          |    |          |
|----|----------|----|----------|----|----------|
| a. | Q onto R | b. | Q onto S | c. | Q onto T |
| d. | R onto Q | e. | R onto S | f. | R onto T |
| g. | S onto Q | h. | S onto R | i. | S onto T |
| j. | T onto Q | k. | T onto R | l. | T onto S |

**CORRECT YOUR WORK. ANSWERS ARE AT THE END OF SUB-STRAND 4.**

## Lesson 22: Symmetry



In the previous lesson, you looked at rotations of objects and shapes.



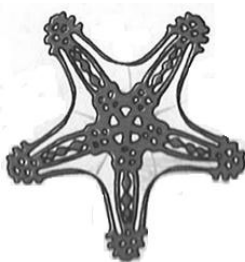
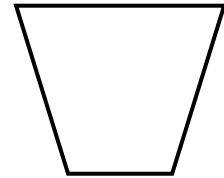
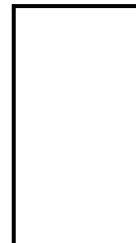
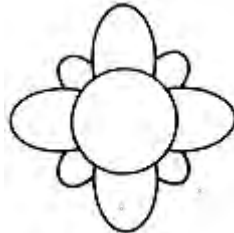
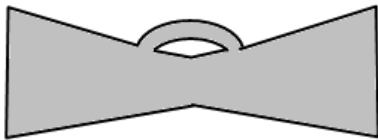
In this lesson, you will:

- define symmetrical shapes
- identify the axis of symmetry
- determine how many axes of symmetry an object has.

Many shapes are symmetrical. These shapes are all around us whether they are manmade things or shapes that occur in nature.

**Symmetrical shapes are shapes or objects that have two halves that are exactly the same shape and size.**

Below are examples of symmetrical shapes and figures.



Symmetry exists all around us and many people see it as being a thing of beauty.

What is Symmetry?



**Symmetry is the exact likeness in shape and size. It is when one half exactly folds onto the other half.**

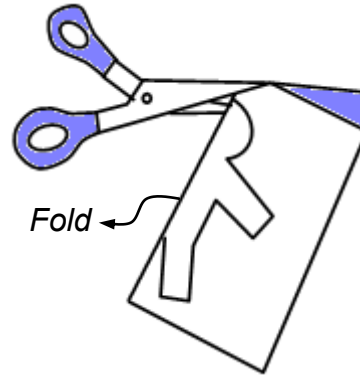
Try the following activities to have a better understanding of the meaning of symmetry.

### Activity 1

You will need a pair of scissors, a piece of blank paper and pencil.

Here is what you do.

1. Fold a piece of blank paper in half.
2. Cut any shape from the folded edge.
3. Open your folded piece of paper. What do you see?



This is what your shape looks like.

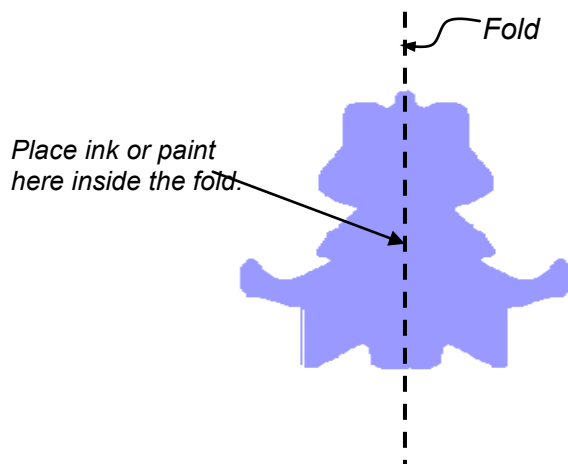


### Activity 2

You will need some ink or paint, and a piece of blank paper.

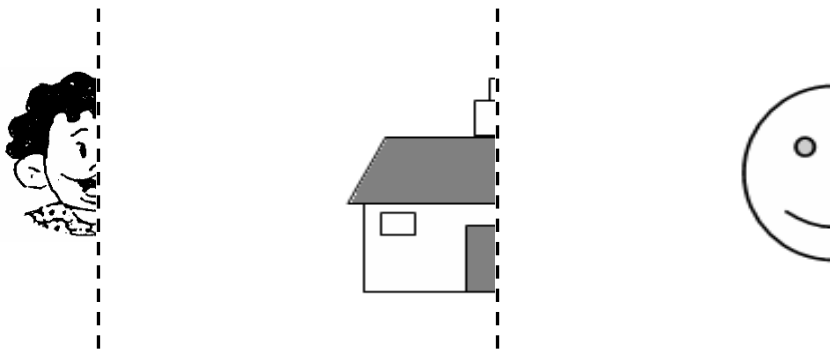
Here is what you do.

Fold your piece of blank paper in half. Place a small amount of ink or paint in the fold. Close the folded paper and press it to make the ink or paint in different directions. Open your paper again. You have made your own ink or paint design.



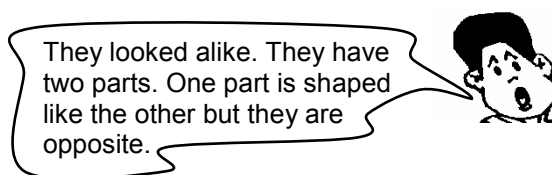
### Activity 3

Hold a mirror along the dotted line. What do you see? You should see the complete picture. The half that is missing from the drawing appears in the mirror as a mirror image.



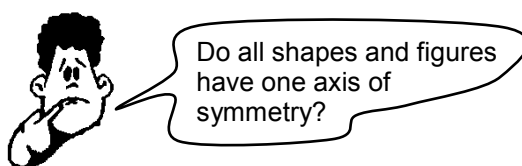
You have done three different activities.

What do you notice about all the shapes you have made?



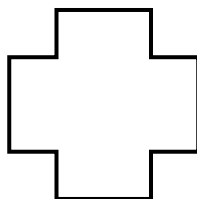
The two halves of the shapes are symmetrical about the dotted line. The dotted line is called the **axis of symmetry**.

**The axis of symmetry is the line dividing the shape into two identical parts that are mirror images of each another.**



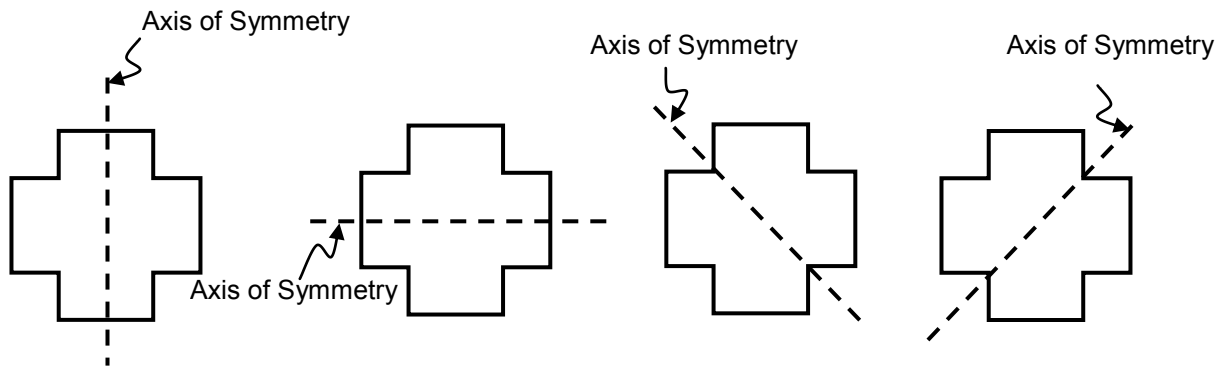
Not all shapes and figures have axis of symmetry but some have more than one axes of symmetry.

Take a look at the shape below.



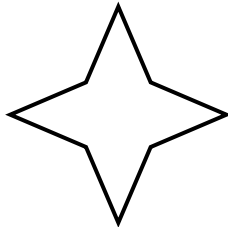
How many different times can the shape or figure be divided into two identical parts?

Look at the shape again with the axis of symmetry drawn.

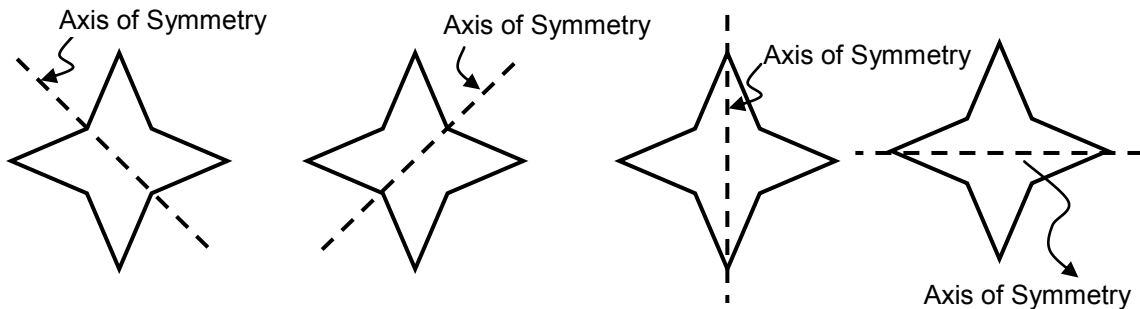


The shape is divided into two identical parts four times along the dotted lines. There are four dotted lines. The shape has four (4) axes of symmetry.

Here is another shape.



Look at the shape again with the axis of symmetry drawn.



The shape is divided into two identical parts four times along the dotted lines. There are four dotted lines. The shape has four (4) axes of symmetry.

**The number of axis of symmetry of a shape or figure depends on the number of times a shape or figure can be divided into two identical parts.**

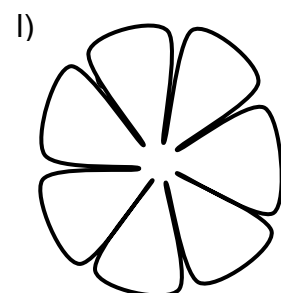
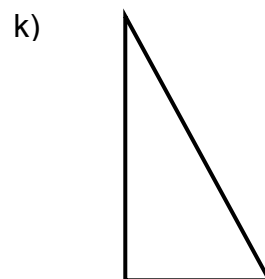
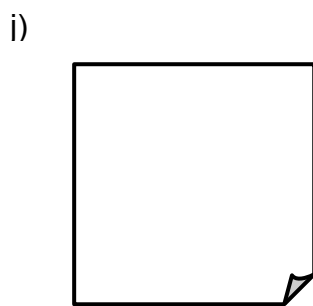
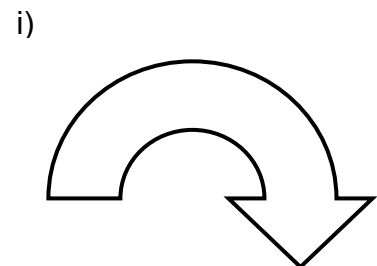
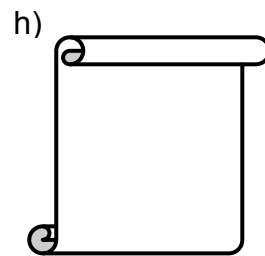
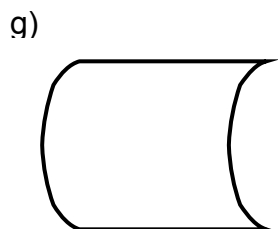
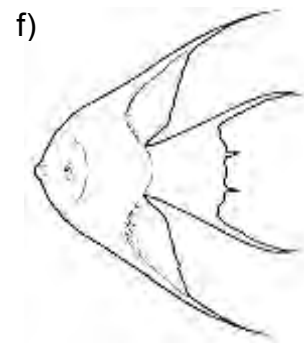
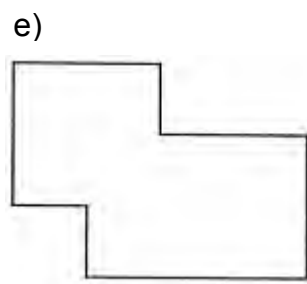
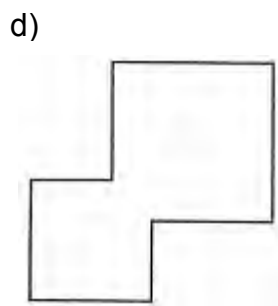
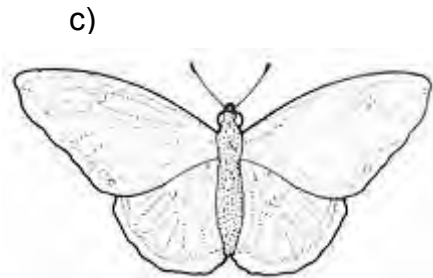
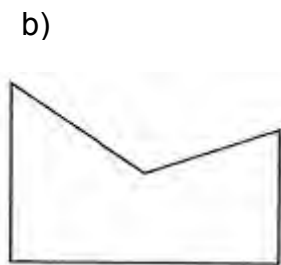
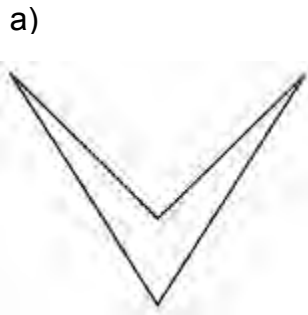
More about axis of symmetry will be discussed in the next lesson.

**NOW DO PRACTICE EXERCISE 22**

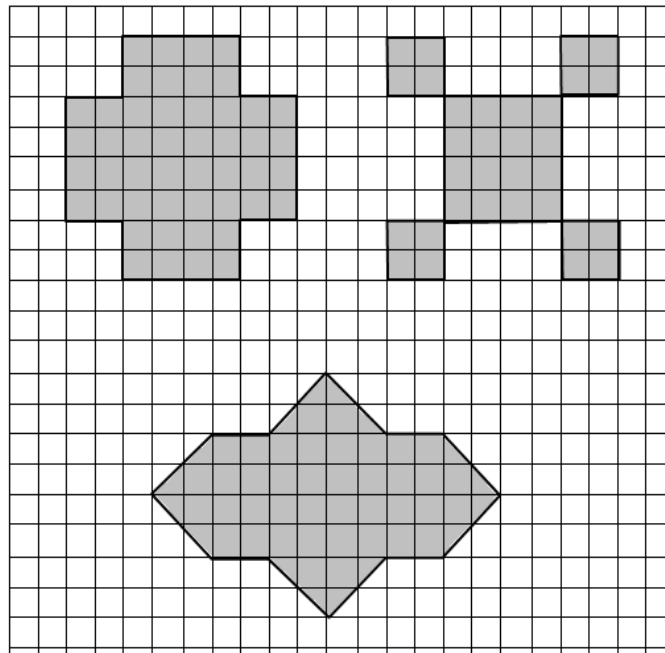
**Practice exercise 22**

1. Some of the shapes below have one axis of symmetry and some have none.

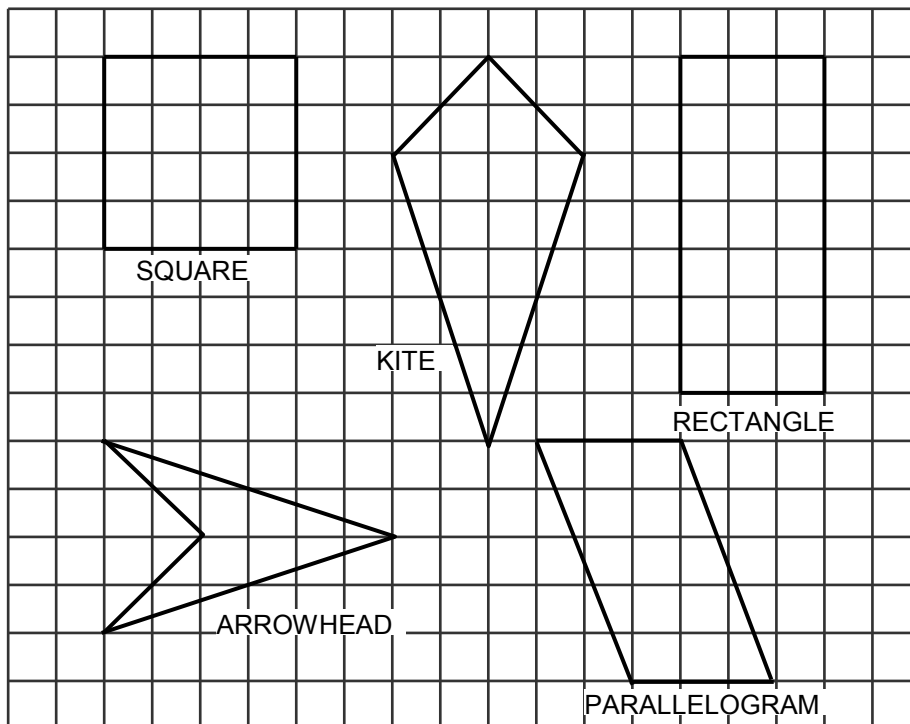
Which of the shapes have an axis of symmetry?



2. Study the shapes and draw dotted lines to indicate the axes of symmetry.



3.



List down the name of the shapes that are symmetrical and their corresponding number of axes of symmetry

**CORRECT YOUR WORK. ANSWERS ARE AT THE END OF SUB-STRAND 4.**



## Lesson 23: Line Symmetry



In the previous lesson, you learnt the meaning of symmetrical shapes and identified axis of symmetry.



In this lesson, you will:

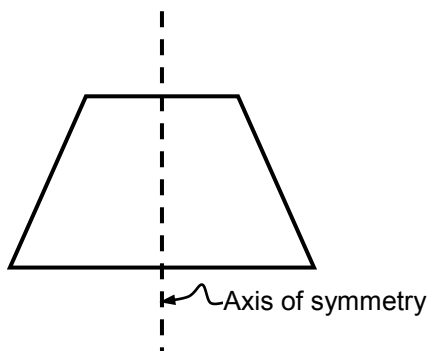
- define line symmetry
- draw axis of symmetry of different objects
- determine which shapes have line symmetry.

You learnt that many shapes are symmetrical. This means that they seem to be balanced and in the right proportion. In mathematics, there are two types of symmetry: the Line Symmetry (Reflectional Symmetry) and Point Symmetry (Rotational Symmetry).

### Line Symmetry

We know that a symmetrical shape is a shape that, if you draw a straight line from one point of it to the other, will cut the shape exactly in half so that the same image is on both sides. The line is called mirror line or the axis of symmetry.

For example, this shape below is symmetrical because a mirror line can be drawn on it.

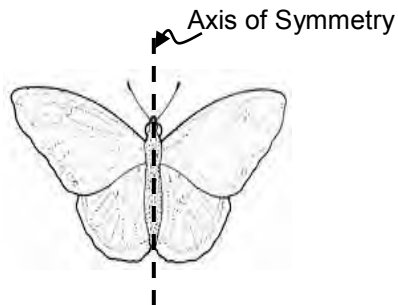


We say that the shape has **line symmetry** or **reflectional symmetry**.

- **Line Symmetry** or **Reflectional Symmetry** is when one half of the shape reflects onto the other when a mirror line or axis of symmetry is drawn on it.
- **Reflectional symmetry** describes pictures, shapes of objects that look exactly the same when divided into 2 halves. The two identical parts are mirror images of one another.
- The dividing line is called an *axis of symmetry*. (Note: the plural for „axis“ is „axes“, pronounced „æ-ease“;)

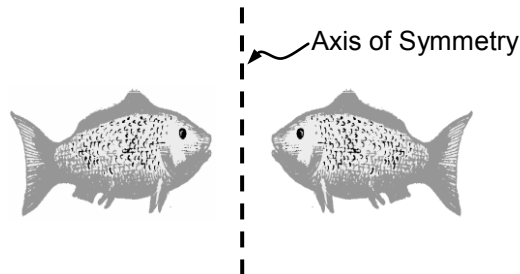
## Example 2

The butterfly has line symmetry or reflectional symmetry because one side of the line is a mirror image or reflection of the other side



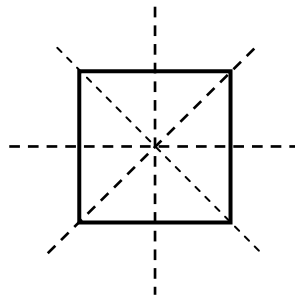
## Example 3

The two halves of the picture are symmetrical about the dotted line. The dotted line is the axis of symmetry.



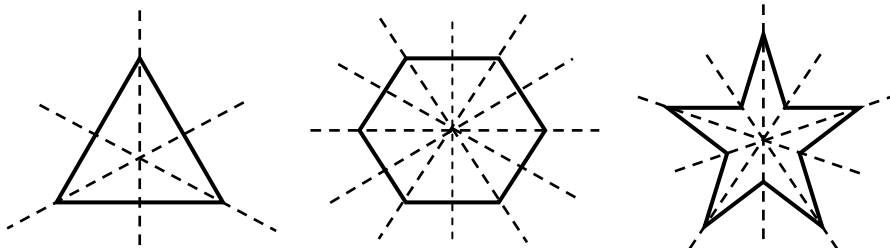
Some shapes have several lines or axes of symmetry.

For example, if you cut a perfect square in half from top to bottom, or side to side, or diagonal to diagonal, both sides are symmetrical. The square has four axes or lines of symmetry.



Axes of symmetry can be horizontal, vertical or diagonal.

The shapes shown below have more than one axis of symmetry.



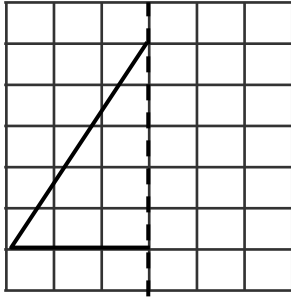
**NOW DO PRACTICE EXERCISE 23.**



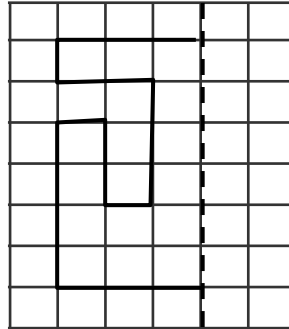
## Practice exercise 22

1. Copy and complete the other half of the pictures below on a squared paper using the dotted line as an axis of symmetry.

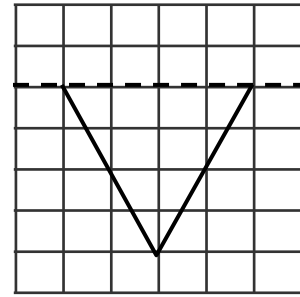
a)



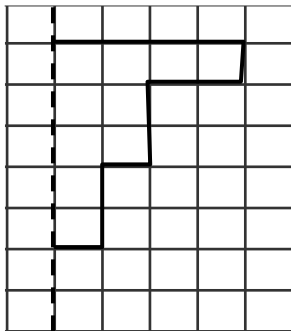
b)



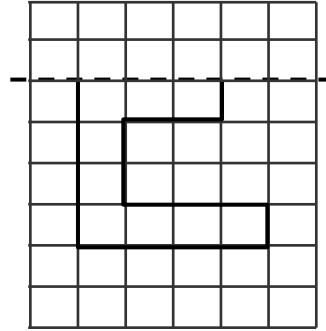
c)



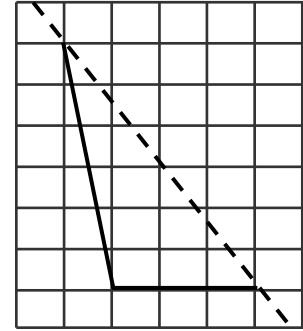
d)



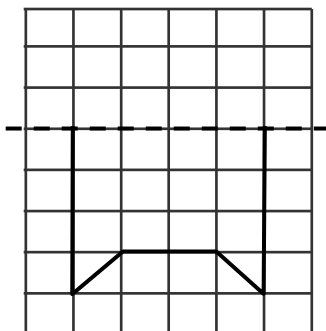
e)



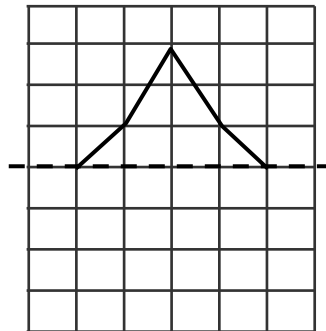
f)



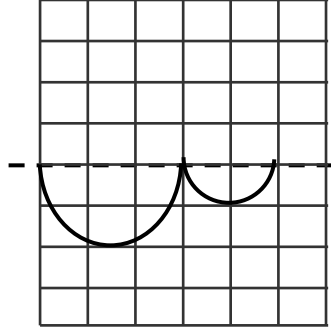
g)



h)



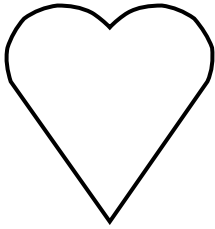
i)



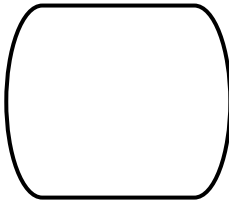
2. Write the word "LOVE" using capital letters. Write down the letters that have axis of symmetry and show the axes of symmetry.

3. Draw the axis of symmetry of the following shapes.

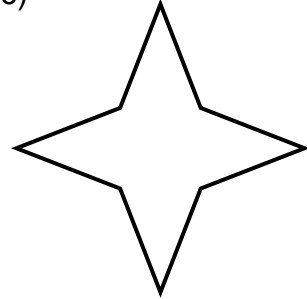
a)



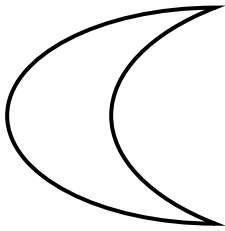
b)



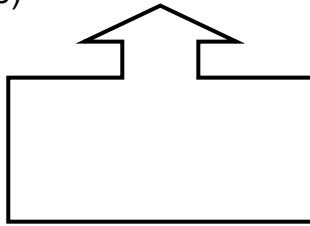
c)



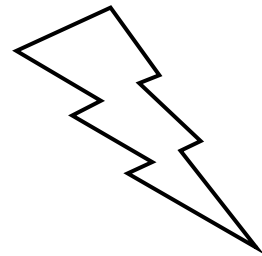
d)



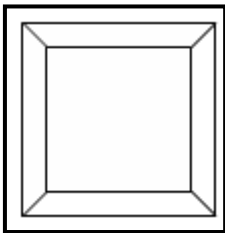
e)



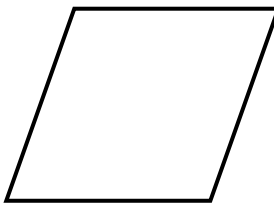
f)



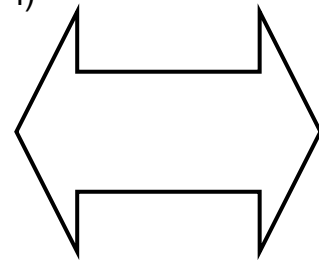
g)



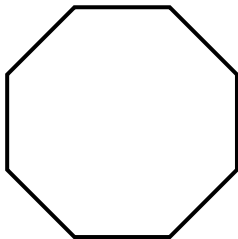
h)



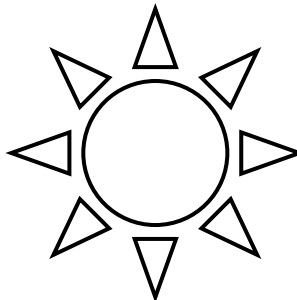
i)



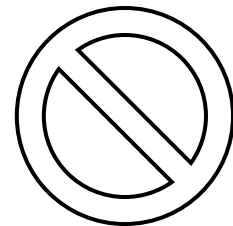
j)



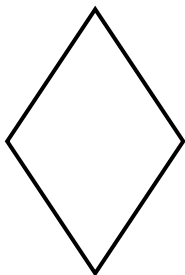
k)



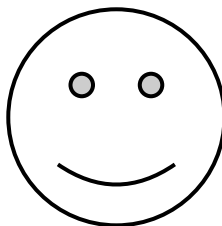
l)



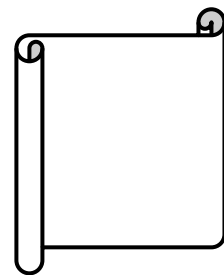
m)



n)



o)



**CORRECT YOUR WORK. ANSWERS ARE AT THE END OF SUB-STRAND 4.**

## Lesson 24: Rotational Symmetry



In the previous lesson, you learnt the meaning of line symmetry and reflectional symmetry.



In this lesson, you will:

- define rotational symmetry
- determine which shapes have point of symmetry.

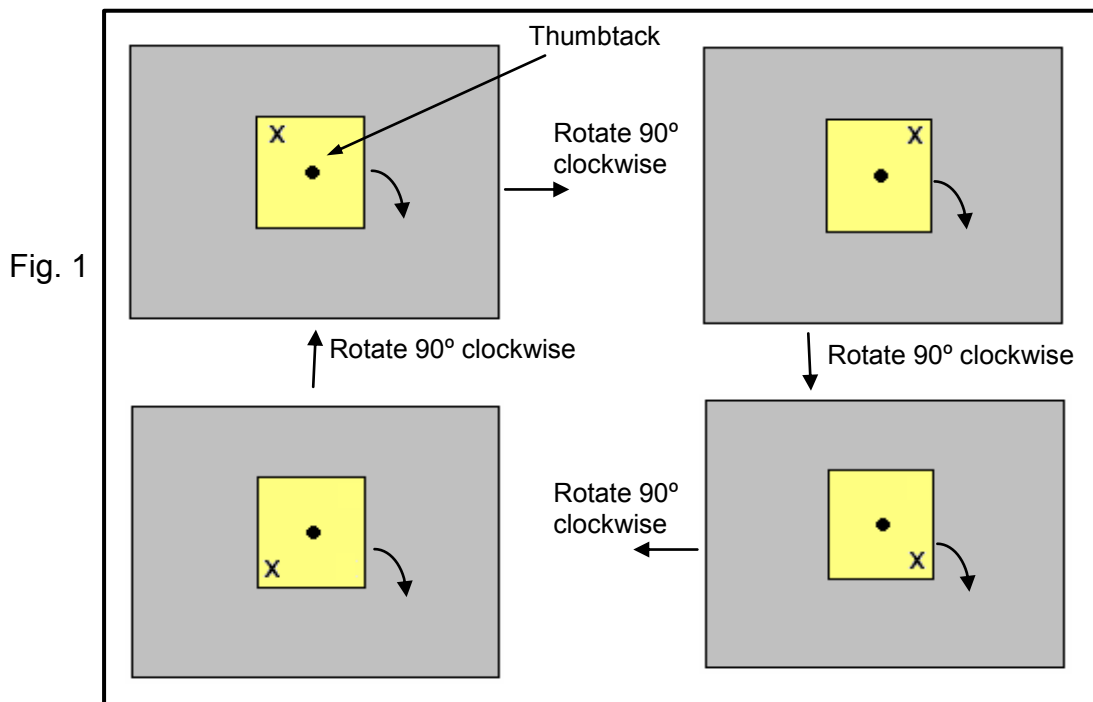
We will start by doing an activity which will help you understand and find out about Rotational Symmetry.

### Activity 1

You will need the following:

Sheets of cardboard, thumbtack, pair of scissors

Cut a square shape from a sheet of cardboard. Attach the square to another bigger piece of cardboard by placing a thumbtack at the centre of the square as shown in Fig. 1. Mark a cross (x) near the corner of the square as shown below.



On the larger cardboard, trace around the shape of the square. Then rotate it 90° clockwise (or anti-clockwise) and trace around it again. The two tracings will coincide. Note the position of the cross (x) after the square is rotated 90° clockwise.

We say that the square has **Point Symmetry** or **Rotational Symmetry**. The point about which the shape rotates (thumbtack) is called the **centre of rotational symmetry**.

**Point Symmetry or Rotational Symmetry is when a shape remains the same when rotated through any angle less than 360°.**



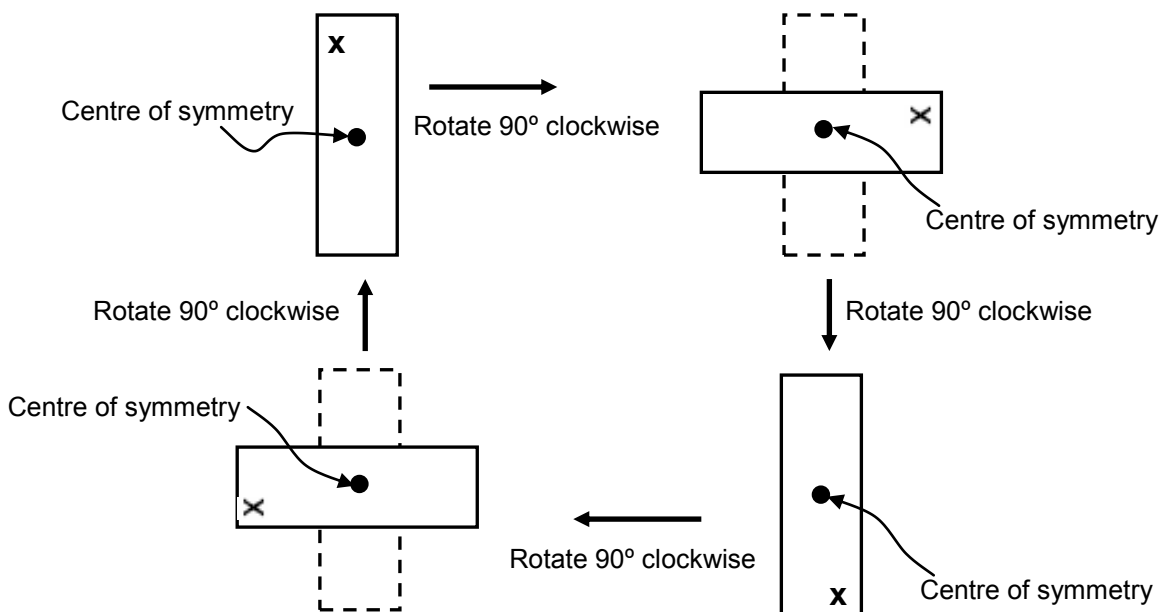
How many times do we have to repeat the process to get back to the original position of the square in Fig.1?

The answer is 4. We say that the **order of rotational symmetry** is 4.

Notice that  $4 = \frac{360^\circ}{90^\circ}$  or  $4 \times 90^\circ = 360^\circ$ . Therefore, if we repeat the process more than 4 times, the rotation goes beyond 360°, we get the same positions over again. So,

**The Order of Rotational Symmetry is the number of distinct ways in which a shape or figure can map onto itself by rotation.**

Let us carry out the same activity illustrated by rotating a rectangular shape



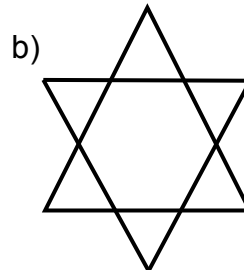
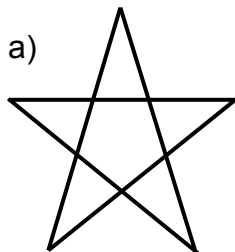
Notice that to get the tracing to coincide, we need to rotate the rectangle 180° clockwise and doing this two times, we get the rectangle back to its original position. Therefore, the order of rotational symmetry is 2.

**Shapes with point symmetry (half-turn symmetry) have a special property. Every point on the figure has a matching point on the figure. These points are the same distance from the centre of symmetry, and if they are joined by a line, the line passes through the centre of symmetry.**

Here are some more examples.

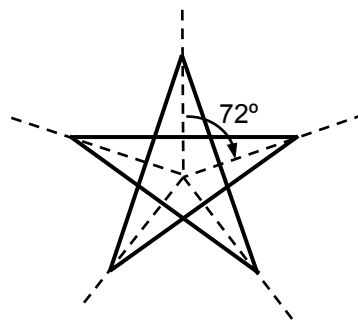
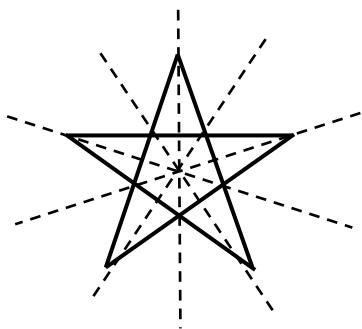
For the figures below, write down the:

1. number of lines of symmetry
2. the order of rotational symmetry



Solution:

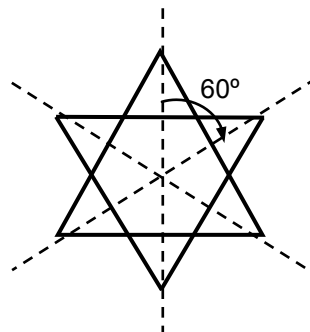
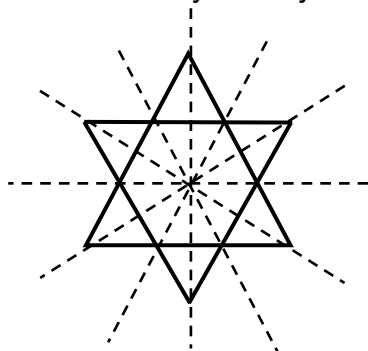
- a) 1. Number of lines of symmetry = 5  
2. Order of rotational symmetry = 5



Each rotation of  $72^\circ$  (clockwise or counter-clockwise) will give us a distinct way in which the figure can map or fit onto itself.

$$\text{Number of distinct ways} = \frac{360^\circ}{72^\circ} = 5$$

- b) 1. Number of lines of symmetry = 6  
2. Order of rotational symmetry = 6

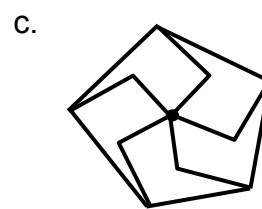
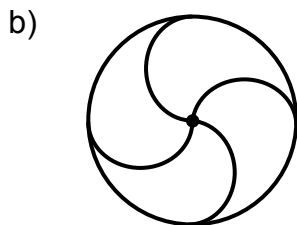
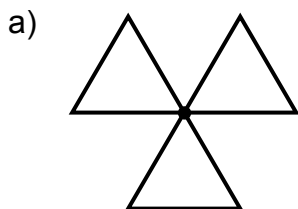


Each rotation of  $60^\circ$  gives us a distinct way in which the figure can map or fit onto itself.

$$\text{Number of distinct ways} = \frac{360^\circ}{60^\circ} = 6$$

Some shapes that do not possess line symmetry still appear to have some symmetrical properties.

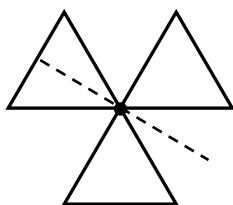
Look at these figures. Do these shapes have point symmetry?



Solution:

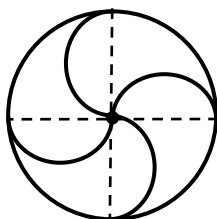
Draw a line from any point through the centre. Is there a matching point on the other side of the centre the same distance away? If the answer is yes for every point on the figure, it has point symmetry.

For figure **a**, the answer is **no**.



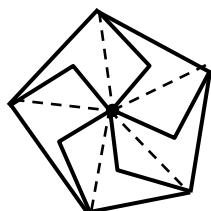
No matching point on the other side of the centre the same distance away.

For figure **b**, the answer is **yes**.



Because in one complete rotation, the tracing fits four times. It is said to have rotational symmetry of order 4.

For figure **c**, the answer is **yes**.



Because in one complete rotation, the tracing fits four times. It is said to have rotational symmetry of order 4.

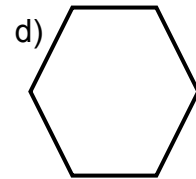
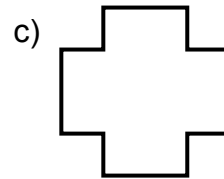
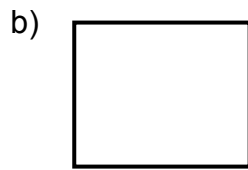
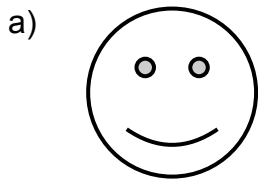
**NOW DO PRACTICE EXERCISE 24.**





## Practice exercise 24

1. State the order of rotational symmetry of each shape below.

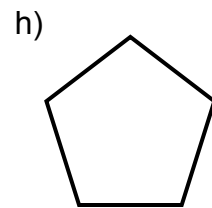
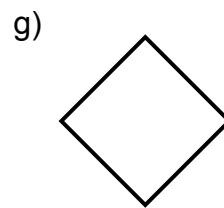
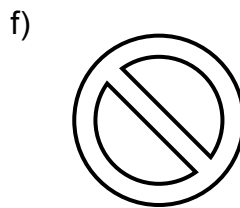
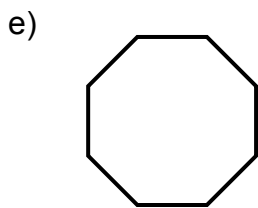


Answers: \_\_\_\_\_

\_\_\_\_\_

\_\_\_\_\_

\_\_\_\_\_

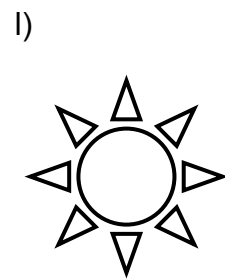
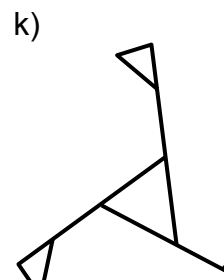
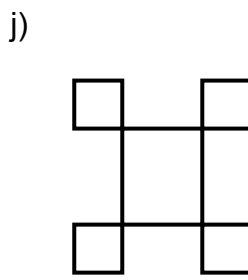
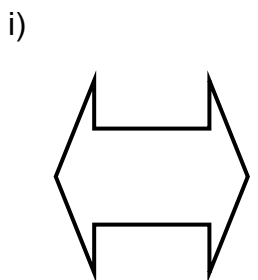


Answers: \_\_\_\_\_

\_\_\_\_\_

\_\_\_\_\_

\_\_\_\_\_

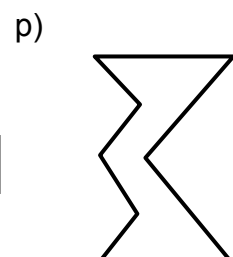
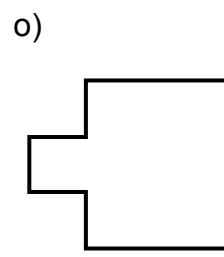
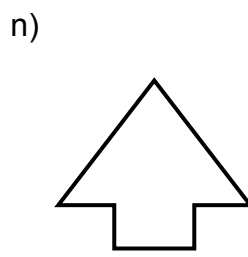
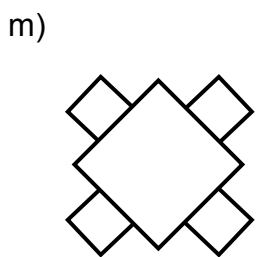


Answers: \_\_\_\_\_

\_\_\_\_\_

\_\_\_\_\_

\_\_\_\_\_



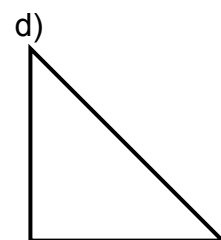
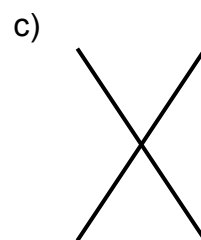
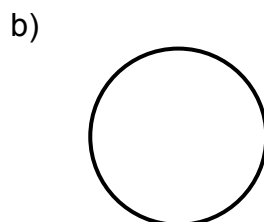
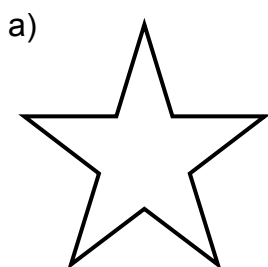
Answers: \_\_\_\_\_

\_\_\_\_\_

\_\_\_\_\_

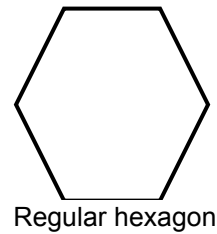
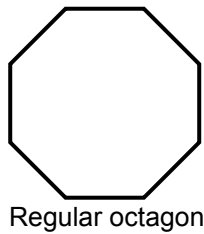
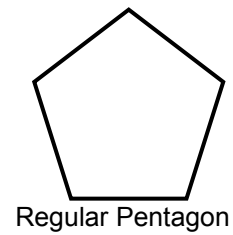
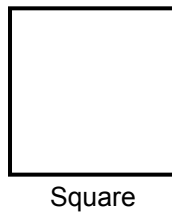
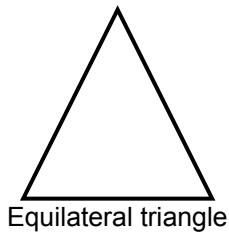
\_\_\_\_\_

2. Which of the following shapes have rotational symmetry?



Answers: \_\_\_\_\_

3. Here are some regular polygons.



- Mark their lines of symmetry using pencil and ruler.
- Use different coloured pencil to mark centres of rotational symmetry. Draw arcs showing angle of rotational symmetry. (Figure 1 is an example of what is to be done.)

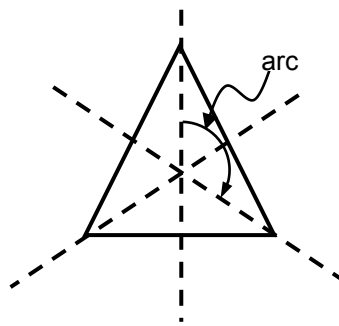


Figure 1

---

**CORRECT YOUR WORK. ANSWERS ARE AT THE END OF SUB-STRAND 4.**

## SUB-STRAND 4: SUMMARY



*In this summary you will find some of the important ideas and terms to remember.*

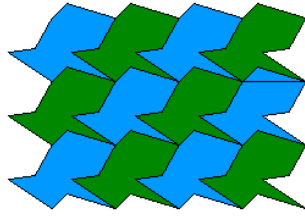
- A tessellation is created when a shape is repeated over and over again. All the figures fit onto a flat surface exactly together without any gaps or overlaps. Another word for tessellation is *tiling*.
- When shapes are congruent, they have the exact size and shape.
- Regular polygons are polygons whose sides and angles are equal and congruent.
- A regular tessellation is made up of congruent regular polygons.
- There are only three regular polygons that tessellate in a plane: these are the triangle, the square and the hexagon. The pattern is identical at each vertex.
- A semi-regular tessellation is made up by using two or more different regular polygons. The pattern at each vertex must be the same.
- Translation means a „shift“ or sliding the shape without turning, rotating, resizing or anything else, just moving.
- Translations are often written in a vertical bracket like this  $\begin{pmatrix} +5 \\ +4 \end{pmatrix}$ . The horizontal movement is always put at the top of the bracket. Plus signs (+) show that the movement is to the right or up while the minus signs (–) show that the movement is to the left or down.
- Rotation came from the word „rotate“ which means „to move in a circle round a central point“. When a shape or an object rotated, it moves around a central point called the „centre of rotation“ through a certain angle. The shape is still congruent to the original shape.
- The angle between the original position of a shape and its new position is called the „angle of rotation“.
- Symmetry is the exact likeness in shape and size. Shapes are symmetrical when one half exactly folds onto the other half.
- There are two kinds of symmetry: The Line symmetry“ or Reflectional symmetry and the Point symmetry or Rotational symmetry.
- A shape has line symmetry if it can be divided by a line into two identical parts that are mirror images of one another. The dividing line is called an „axis of symmetry“.
- Point symmetry or Rotational symmetry is when a shape remains the same when rotated through any angle less than 360 degrees.
- The Order of Rotational Symmetry is the number of distinct ways in which a shape or figure can map onto itself by rotation.
- Shapes with point symmetry (half-turn symmetry) have a special property. Every point on the figure has a matching point on the figure. These points are the same distance from the centre of symmetry, and if they are joined by a line, the line passes through the centre of symmetry.

**REVISE LESSONS 19-24 THEN DO SUB-STRAND TEST 4 IN ASSIGNMENT 2.**

## ANSWERS TO PRACTICE EXERCISE 19 – 24

---

### Practice Exercise 19



### Practice Exercise 20

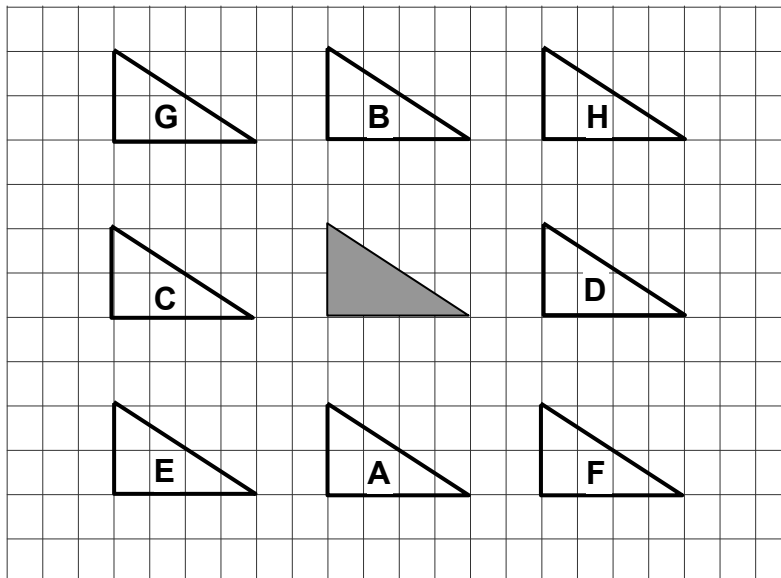
1. A  $\begin{pmatrix} -5 \\ +5 \end{pmatrix}$     B  $\begin{pmatrix} -5 \\ 0 \end{pmatrix}$     C  $\begin{pmatrix} -5 \\ -6 \end{pmatrix}$     D  $\begin{pmatrix} -2 \\ +8 \end{pmatrix}$     E  $\begin{pmatrix} 0 \\ +4 \end{pmatrix}$

F  $\begin{pmatrix} +5 \\ 0 \end{pmatrix}$     G  $\begin{pmatrix} +6 \\ +6 \end{pmatrix}$     H  $\begin{pmatrix} +8 \\ +2 \end{pmatrix}$     I  $\begin{pmatrix} +7 \\ -4 \end{pmatrix}$     J  $\begin{pmatrix} 0 \\ -5 \end{pmatrix}$

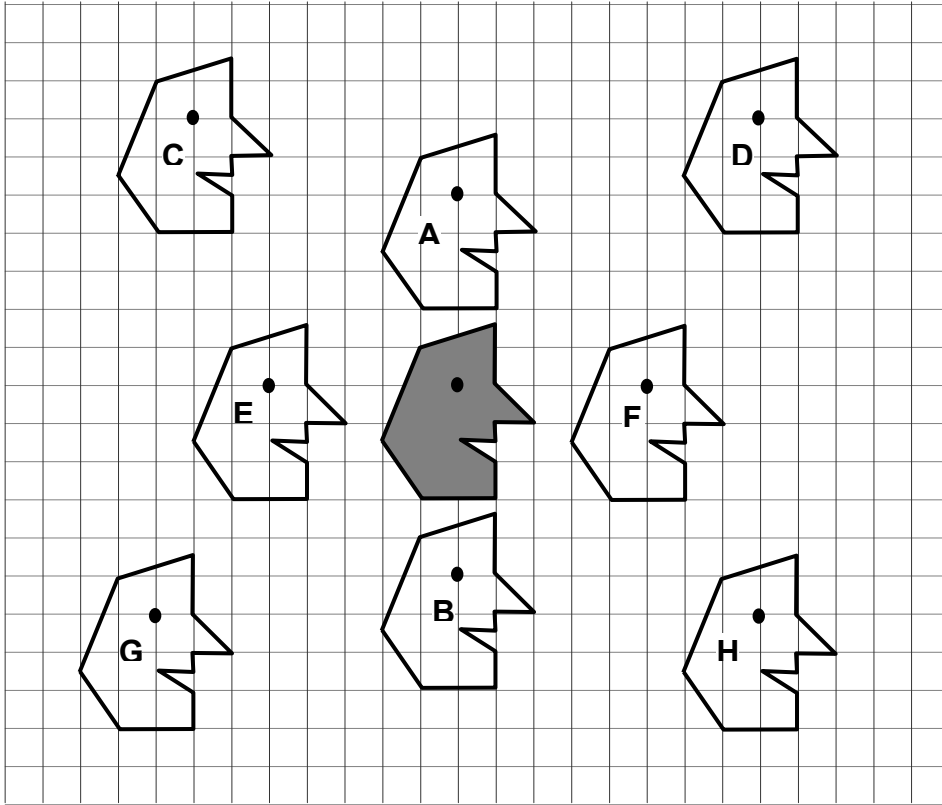
2. A  $\begin{pmatrix} -7 \\ +6 \end{pmatrix}$     B  $\begin{pmatrix} -2 \\ +7 \end{pmatrix}$     C  $\begin{pmatrix} +3 \\ +5 \end{pmatrix}$     D  $\begin{pmatrix} +8 \\ +7 \end{pmatrix}$     E  $\begin{pmatrix} -6 \\ 0 \end{pmatrix}$

F  $\begin{pmatrix} +7 \\ +1 \end{pmatrix}$     G  $\begin{pmatrix} -1 \\ -5 \end{pmatrix}$     H  $\begin{pmatrix} -6 \\ -8 \end{pmatrix}$     I  $\begin{pmatrix} +8 \\ -5 \end{pmatrix}$     J  $\begin{pmatrix} +3 \\ -10 \end{pmatrix}$

3.



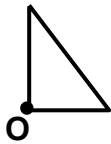
4.



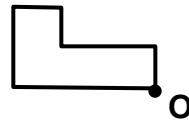
**Practice Exercise 21**

1.

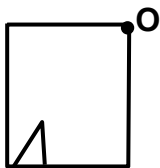
a)



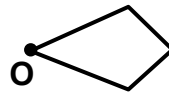
b)



c)



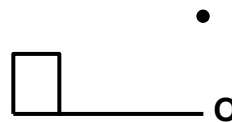
d)



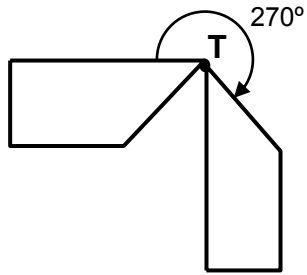
e)



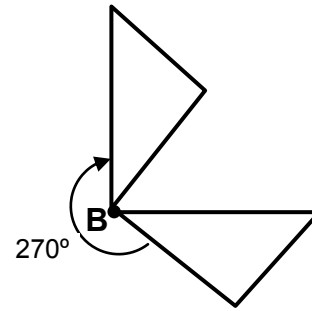
f)



2. a)



b)

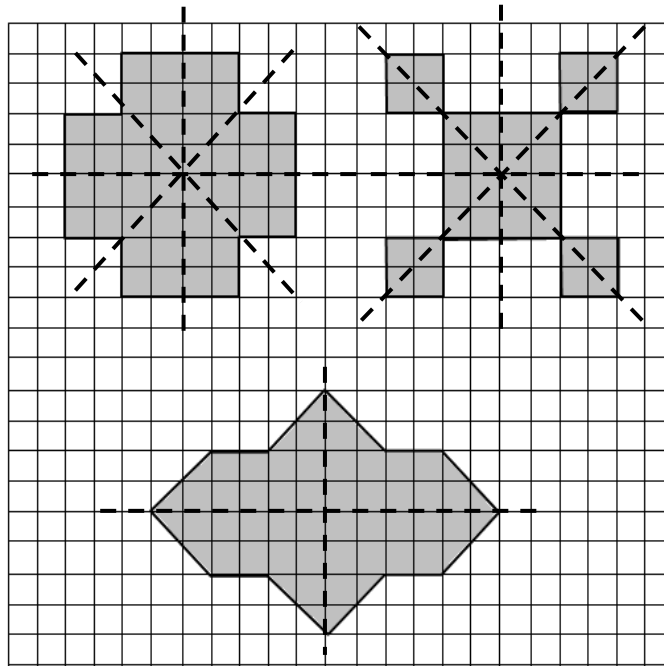


- |    |    |             |    |             |    |             |
|----|----|-------------|----|-------------|----|-------------|
| 3. | a) | $270^\circ$ | e) | $270^\circ$ | i) | $270^\circ$ |
|    | b) | $180^\circ$ | f) | $180^\circ$ | j) | $270^\circ$ |
|    | c) | $90^\circ$  | g) | $180^\circ$ | k) | $180^\circ$ |
|    | d) | $90^\circ$  | h) | $90^\circ$  | l) | $90^\circ$  |

### Practice Exercise 22

1. a, c, d, f, g, l

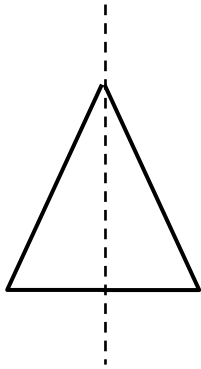
2.



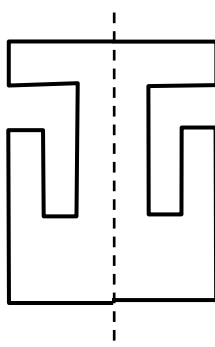
- |    |           |                      |
|----|-----------|----------------------|
| 3. | Square    | = 4 axes of symmetry |
|    | Kite      | = 1 axis of symmetry |
|    | rectangle | = 2 axes of symmetry |
|    | arrowhead | = 1 axis of symmetry |

**Practice Exercise 23**

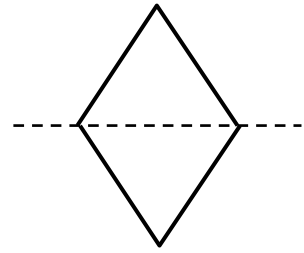
1. a)



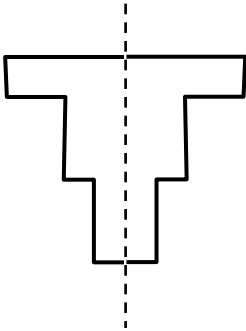
b)



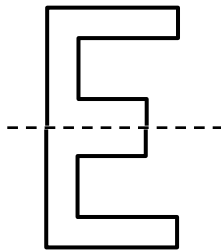
c)



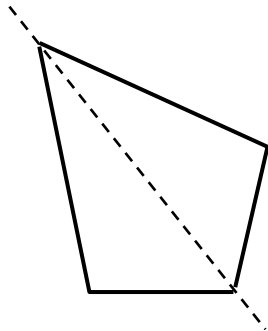
d)



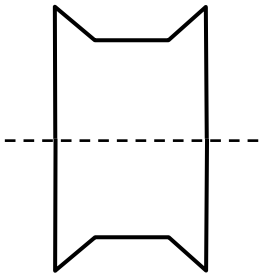
e)



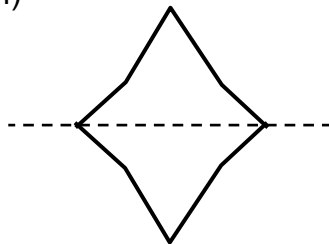
f)



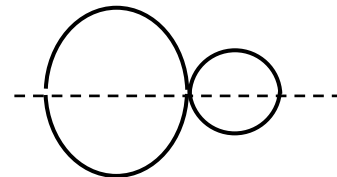
g)



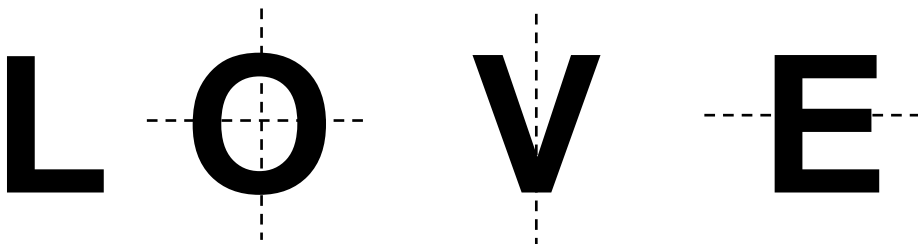
h)



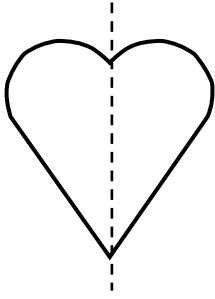
i)



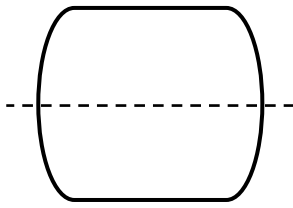
2



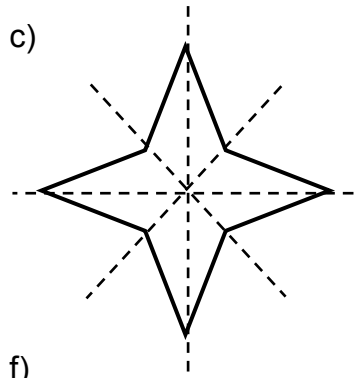
3. a)



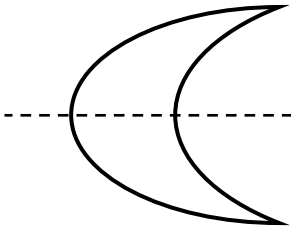
b)



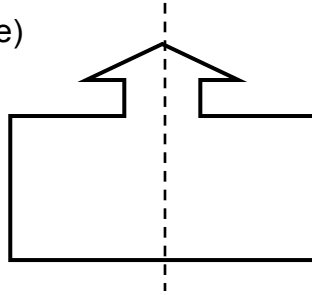
c)



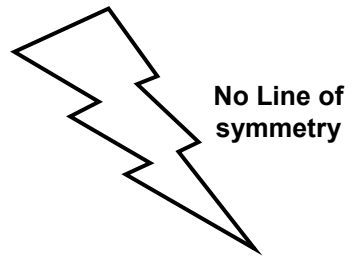
d)



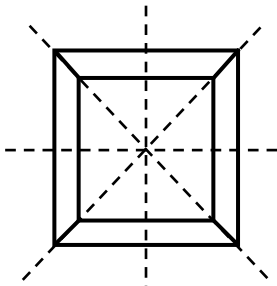
e)



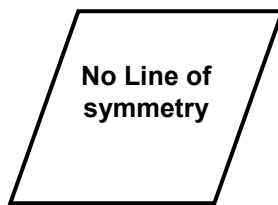
f)



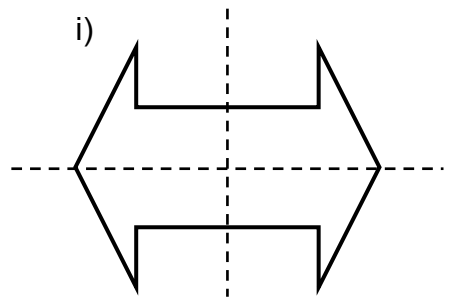
g)



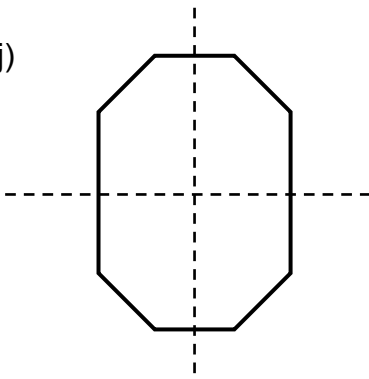
h)



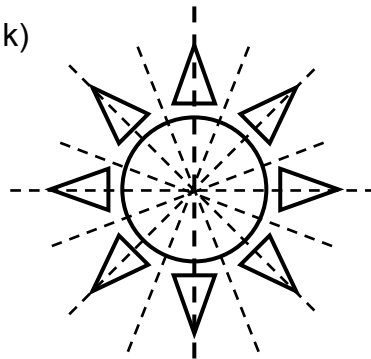
i)



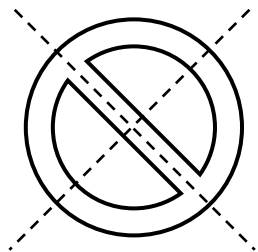
j)



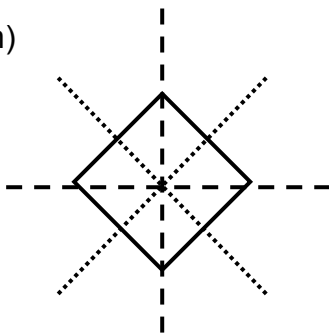
k)



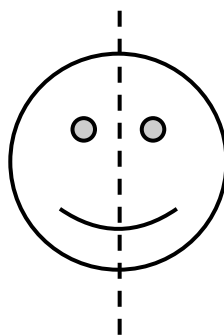
l)



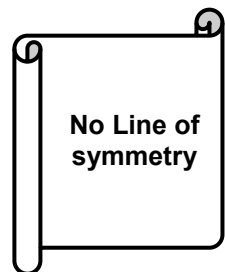
m)



n)



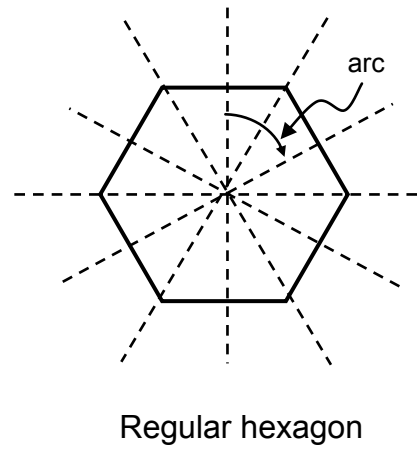
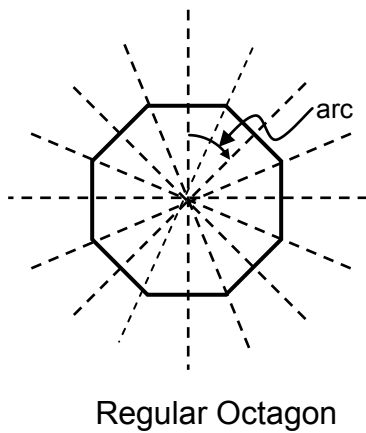
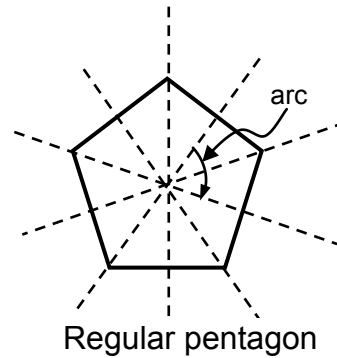
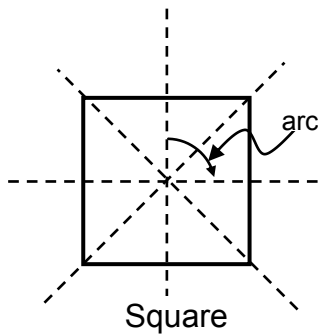
o)





**Practice Exercise 24**

1. a) 1    b) 2    c) 4    d) 6  
 e) 8    f) 2    g) 4    h) 5  
 i) 2    j) 4    k) 3    l) 8  
 m) 4    n) 1    o) 2    p) 2
2. a, b, and c
3. a)



**END OF SUB-STRAND 4**

**NOW YOU MUST COMPLETE ASSIGNMENT 2.  
 RETURN IT TO THE PROVINCIAL COORDINATOR.**

## REFERENCES

---

- **Outcome Based Mathematics 7A and 7B**
  - NDOE(1995) **Secondary Mathematics 8A and 8B**
  - **Developmental Mathematics Book 1 and 2** Fourth Edition by A. Thompson and E. Wrightson, revised by: S. Tisdell McGraw Hill, Australia
  - **New General Mathematics** Complete Edition by Ewart Smith; Stanley Thornes LTD. Publisher
  - **New Signpost Mathematics 7 and 8** by A. Mcseveny, R. Conaway and S. Wilkens,
  - Longman Outcomes, **Maths for Qld 1**, by Chris Lynagh, Paul Barns and David Barton
  - **Moving Ahead with Mathematics 1**, Mathematics Textbook for First Year High School, Public School Edition, First Edition, 1997, DECS Philippines
  - **Mathematics 1 for first Year High School**; DECS, Republic of the Philippines, SEDP Series
  - **New Secondary School Mathematics for First Year** by: M.R. Amores, R. Cruz, C. Barundia and A. Go
  - **Worked examples for Mathematics Outcomes Upper Primary**; Department of Education, PNG
  - **Maths for Qld 1 and 2**, by: Paul Burns and Chris Lynagh
  - **School Mathematics of East Africa**, Book 2; East African Publishing House and Cambridge University Press
  - **<https://www.mathsisfun.com/definitions/tessellation.html>**
  - **[www.coolmath.com/lesson-tessellations-1](http://www.coolmath.com/lesson-tessellations-1)**
  - **The Mathematics of Tessellation** © 2000 Andrew Harris, St Martins College
-